

Metal bellows compact seal suitable for Sundyne Pumps

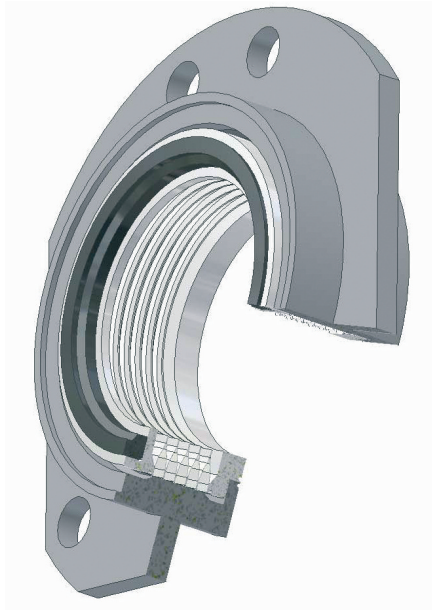

The medium lubricated metal bellows compact seal **type KPB** is specially designed for the application in Sundyne high speed centrifugal pumps.

Identical dimensions with the original seals allow easy installation and interchangeability.

By using a welded flexible metal bellows a secondary seal (e.g. dynamic o-ring etc.) and the seal springs are no longer necessary thus avoiding any possible fretting damage or seal hang up.

The metal bellows compact seal **type KPB** makes a considerably contribution towards reducing down time and maintenance cost.

Two seal sizes are available:

KPB-317 - lower mechanical seal, Pos. 60A

KPB-381 - upper mechanical seal, Pos. 60B

Single Seal Arrangement

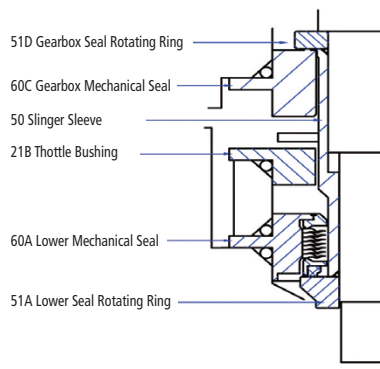

Tandem Seal Arrangement

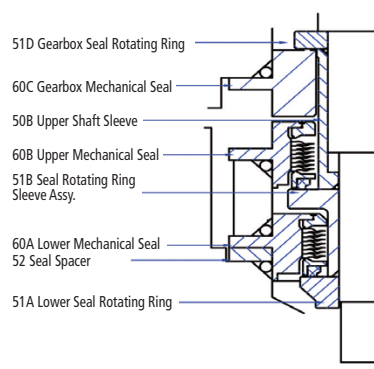

Double Seal (Face to Face) Arrangement

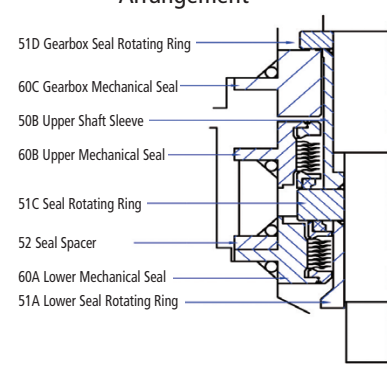

Operation limits

Pressure:	max. 20barg
Temperature:	-50°C to + 300°C
Speed:	max. 22.000 rpm
Specific weight:	≥ 0,65 kg/dm3

Standard materials

Seal face:	carbon resin impr.
Metal bellows:	AM 350
Other components:	stainless steel

further materials on request