

Assembly and operating instructions

# DULCOMETER Aegis-II® Cooling Tower and Boiler Controller

Use your Tablet or Smartphone. I'm WiFi ready!



Please carefully read these operating instructions before use! - Do not discard this manual! The operator shall be responsible for any damage caused by installation or operating errors! Technical changes reserved.

---

# Table of Contents

---

<b>1</b>	<b>OPERATING CONCEPT</b>	<b>5</b>
1.1	THE FRONT PANEL	5
1.2	FUNCTIONS OF THE KEYS	6
1.3	CHANGING THE OPERATING LANGUAGE	6
1.4	KEYPAD LOCK	6
<b>2</b>	<b>NAVIGATING THE [MENU] DISPLAY</b>	<b>7</b>
2.1	INPUT/OUTPUT STATUS [MOMENTARY DISPLAY]	8
2.2	MODIFYING THE 'HOME' SCREEN	8
<b>3</b>	<b>IDENTCODE</b>	<b>9</b>
<b>4</b>	<b>SAFETY AND RESPONSIBILITY</b>	<b>14</b>
4.1	EXPLANATION OF THE SAFETY INFORMATION	14
4.2	GENERAL SAFETY NOTES	15
4.3	INTENDED USE	16
4.4	WARRANTY GUIDE	16
4.5	USERS' QUALIFICATIONS	16
4.5.1	Training	17
<b>5</b>	<b>FUNCTIONAL DESCRIPTION</b>	<b>18</b>
<b>6</b>	<b>MOUNTING AND INSTALLATION</b>	<b>19</b>
6.1	SCOPE OF SUPPLY	20
6.2	MECHANICAL INSTALLATION	20
6.2.1	Wall mounting	20
6.3	ELECTRICAL INSTALLATION	21
6.3.1	Specification of the cable grips and conduit entries	22
6.3.2	Sensor Seals and Termination Procedure	23
6.3.3	Parking the Hood	24
6.3.4	General Layout and Terminal Diagrams	24
6.3.5	Power In and Relay Output Termination	31
6.3.6	Frequency Output Termination	34
6.3.7	Wiring sensors to the controller	34
6.3.8	Temperature [Input H]	36
6.3.9	Sensor Driver Cards	36
6.3.10	Dual Serial Input card (CTFs-LPR-DP)	37
6.3.11	Dual CT (Conductivity/Temperature)	38
6.3.12	Dual pH-ORP-Temp Driver	39
6.3.13	ORP/pH Temp mA Input card	41
6.3.14	Dual 4-20mA Input Driver	43
6.3.15	Connection of Amperometric Sensors	43
6.3.16	Dual 4-20mA Output Driver	45
<b>7</b>	<b>COMMUNICATION</b>	<b>46</b>
7.1	DIAGRAM OF THE COMMUNICATION MODULES	46
<b>8</b>	<b>COMMISSIONING</b>	<b>47</b>
8.1	SWITCH-ON BEHAVIOR DURING COMMISSIONING	47
8.2	DEFINING METERING AND CONTROL PROCESSES	47
<b>9</b>	<b>PROGRAMMING THE INPUTS</b>	<b>47</b>
9.1	ANALOG AND DIGITAL INPUTS	48
9.1.1	Enable an Analog or Digital Input	48
9.1.2	Enable a CTFs [Conductivity, Temp, Flow, Serial] Sensor	49
9.2	NAMING AN INPUT OR OUTPUT	49
9.3	CHANGING A DESCRIPTOR	49
9.4	SELECTING AN ANALOG SENSOR TYPE	50
9.4.1	Selecting the sensor type	50
9.5	ANALOG SENSOR CLEANING AND CALIBRATION	50
9.5.1	General remarks	50
9.5.2	Sensor Commissioning	51

9.5.3	Calibrating and checking probes .....	51
9.5.4	Cleaning and servicing probes.....	51
9.5.5	Calibration Notes.....	52
9.6	GENERAL SENSOR CALIBRATION .....	53
9.7	CALIBRATING AN AMPEROMETRIC SENSOR.....	54
9.8	ANALOG SENSOR ALARMS.....	55
9.8.1	Analog Alarm Configuration .....	55
9.9	ANALOG SENSOR DIAGNOSTICS.....	56
9.9.1	pH-ORP Driver card Diagnostics .....	57
9.9.2	CT (Conductivity, Boiler Cond., Condensate and Temperature) Driver card Diagnostics.....	57
9.9.3	The 4-20mA Input Driver Card Diagnostics .....	57
9.9.4	The 4-20mA output Driver Card Diagnostics .....	57
9.9.5	Serial Sensors (CTFs, LPR, DP) Driver Card Diagnostics .....	57
9.10	CONFIGURING DIGITAL INPUTS.....	59
9.10.1	Configure a Digital Input as a Water Meter:.....	59
9.10.2	Link a Water Meter to a Relay (Applies to all relays ).....	60
9.11	DISABLE AN ANALOG OR DIGITAL INPUT .....	61
9.11.1	Changing or Unlinking an Analog Input Tied to an Output Relay .....	62
9.11.2	Changing or Unlinking Analog Inputs Tied to a 4-20mA Output:.....	63
9.11.3	Changing or Unlinking a Digital Input Tied to a Digital Output.....	63
9.11.4	Changing or Unlinking a Digital Input Tied to a 4-20mA Output.....	64
9.12	PHANTOM INPUTS .....	64
<b>10</b>	<b>PROGRAMMING THE CONTROL OUTPUTS (RELAY AND 4-20MA) .....</b>	<b>64</b>
10.1	FREQUENCY/PULSE OUTPUTS:.....	65
10.2	DETERMINE IF A RELAY IS ENABLED:.....	65
10.3	ENABLE AND CONFIGURE A RELAY .....	65
10.4	NAMING THE OUTPUT .....	66
10.5	CONFIGURING A BLOWDOWN RELAY .....	67
10.6	CONFIGURING A FEED RELAY.....	67
10.6.1	Feed Based on a Water Meter.....	68
10.6.2	Feed Based on a Sensor .....	68
10.6.3	Feed Based on Bleed and/or Feed .....	69
10.6.4	Feed Based on Percent Time & Base Feed .....	70
10.6.5	Feed Based on a Sensor with Event Control.....	70
10.6.6	Set up a relay using the Feed mode with an oxidant sensor; ORP or any 4-20mA input.....	70
10.6.7	Choosing a Cycle .....	70
10.7	CONFIGURING AN EVENT-OTHER RELAY.....	71
10.7.1	Schedules, Prebleeding, Lockout and With a Sensor.....	71
10.7.2	Add, Remove, Edit Events .....	72
10.8	INTERLOCKS.....	74
10.8.1	Setting/Removing Interlocks .....	74
10.9	BLOCKS .....	75
10.10	CONTROL ACTION (ON DECREASES/ON INCREASES SENSOR):.....	75
10.11	SPECIAL CONTROL FUNCTIONS: .....	76
10.11.1	Timed Cycling:.....	77
10.11.2	Time Modulate.....	77
10.11.3	PID Control.....	78
10.12	BOILER BLOWDOWN: .....	79
10.12.1	Continuous Boiler Blowdown .....	79
10.12.2	Captured Sample Blowdown.....	79
10.12.3	Varying Cycles: .....	82
10.13	HOW TO SETUP A RELAY AS AN ALARM OUTPUT: .....	83
10.14	PRIME (FORCE ON) A RELAY.....	83
10.15	SENSOR WASH:.....	83
10.16	4-20MA OUTPUTS:.....	84
10.16.1	How to assign 4-20mA output to control decrease (e.g Acid Feed): .....	84
10.16.2	How to assign 4-20mA output to control increase (e.g Caustic Feed):.....	85
10.16.3	How to assign 4-20mA output to measured value (application: feedback to PLC/DCS): .....	85
10.16.4	How to set 4-20mA output to Manual Mode:.....	86
10.16.5	Linking a 4-20mA Input with a 4-20mA Output .....	86
10.16.6	Calibration of a 4-20mA Output.....	87

---

## Table of Contents

---

<b>11 SYSTEM MENU</b> .....	<b>88</b>
11.1 COMMUNICATIONS.....	88
11.1.1 <i>How to Change the IP Address:</i> .....	88
11.1.2 <i>Web Interface Wi-Fi</i> .....	89
11.2 SYSTEM SETUP.....	89
11.2.1 <i>Site Name/Controller Name</i> .....	89
11.2.2 <i>Keypad Passwords</i> .....	89
11.2.3 <i>Metric Units</i> .....	90
11.2.4 <i>Sunday=Day 1</i> .....	90
11.2.5 <i>Number of Systems</i> .....	90
11.2.6 <i>Alarm on Stops</i> .....	90
11.2.7 <i>System Restart and Factory Reset</i> .....	90
11.3 TIME AND DATE:.....	91
11.4 SET SENSOR TYPE.....	91
11.5 PASSWORDS – LOGIN/LOGOUT.....	91
11.5.1 <i>How to Set Keypad Password:</i> .....	91
11.6 ACTIVITY LOG.....	91
11.7 DIAGNOSTICS.....	92
11.8 CONFIGURATIONS.....	93
<b>12 CONTROLLER TECHNICAL DATA:</b> .....	<b>93</b>
12.1 FUSE SPECIFICATION.....	93
12.2 CONTROLLER SPECIFICATIONS.....	94
12.3 SENSOR SPECIFICATIONS.....	95
<b>13 USING THE USB PORT</b> .....	<b>96</b>
13.1 CAPTURING DATA.....	96
13.2 FIRMWARE UPGRADE USING USB.....	97
13.2.1 <i>USB – Save or Load the Program</i> .....	97
13.3 E-MAIL REPORTS AND ALARMS.....	98
13.3.1 <i>E-mail Types:</i> .....	98
<b>14 SPARE PARTS AND ACCESSORIES</b> .....	<b>99</b>
<b>15 MAINTENANCE</b> .....	<b>101</b>
<b>16 CERTIFICATIONS</b> .....	<b>102</b>
<b>17 NECESSARY FORMALITIES</b> .....	<b>102</b>
17.1 DISPOSAL OF USED PARTS.....	102
17.2 AGENCY APPROVALS.....	102

General non-discriminatory approach

In order to make it easier to read, this document uses the male form in grammatical structures but with an implied neutral sense. It is aimed equally at both men and women. We kindly ask female readers for their understanding in this simplification of the text.

Supplementary information

Read the following supplementary information in its entirety!

The following are highlighted separately in the document:

Safety Information

Safety information is provided with detailed descriptions of the hazardous situation. Refer to Section 4 **Safety and Responsibility**.

**i Information**

This type of box provides important information either relating to the correct operation of the system, or is intended to make your work easier.

**1 Operating Concept**

There are two manuals associated with the Aegis II controller, the Assembly and Operating Instruction manual and a Browser manual. The Browser manual covers all Ethernet and WiFi communications and how to program the unit via a PC, tablet or Smartphone. Most programming operations are more easily performed in this manner.

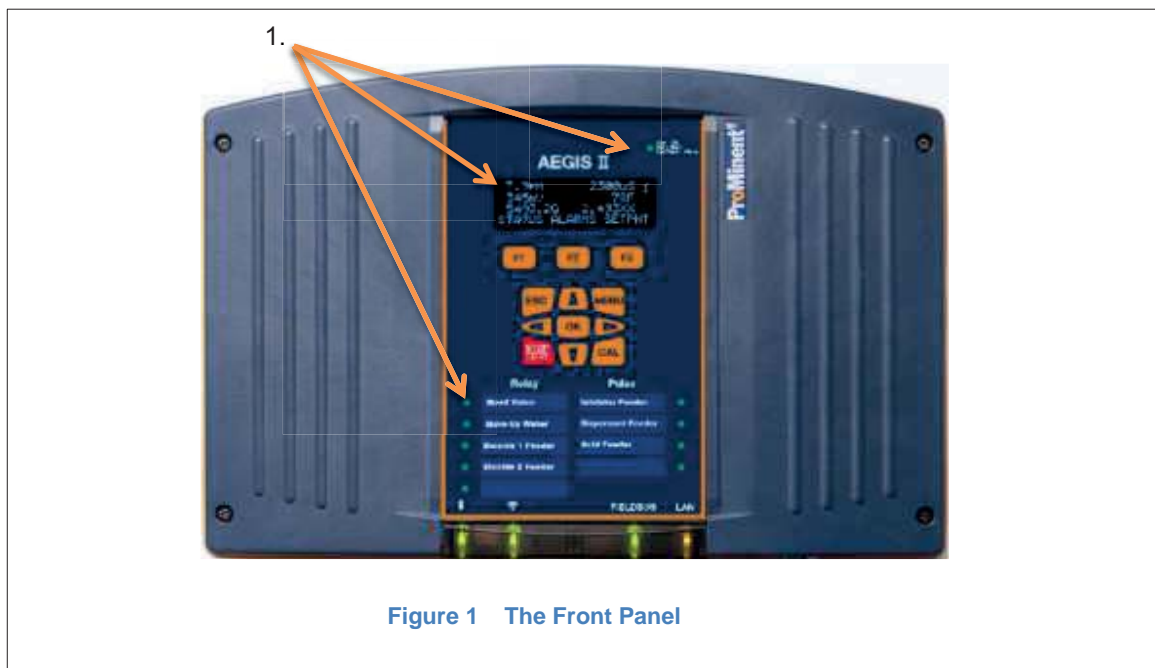

Figure 1 The Front Panel

**1.1 The Front Panel**

The AEGIS II uses an OLED (Organic LED) text display to indicate real time values of up to 6 sensors on the main display, one multicolored

Status LED to indicate alarms and unusual conditions and 9 multicolored LEDs to indicate output status.

**i Status LED**

In the event of an alarm, the controller's status LED at the upper right corner of the keypad changes from 'blue' to 'flashing red'. If one of the feeders is set to manual STOP, the status LED will be 'solid red'.

Figure 2 Status LED









## Menu Navigation

The communication indication panel is located at the bottom center of the controller face. A green light indicates the function is available. If the port is in use, the green light blinks.



**Figure 3 Communication Status LEDs**  
(Bluetooth and Fieldbus are not currently available. Jan 2017)

### 1.2 Functions of the keys

Key	Function
	Confirmation in the menus: Confirms and saves any changes.
	Back to the HOME display or to the previous menu.
	Enables direct access to all of the controller's setting menus.
	Enables direct access to the controller's calibration menu from the HOME display.
	Start/Stop all control outputs from any display. (4-20mA = 4mA). Front panel LED is solid red.
	(Up Arrow) Increases a displayed number value or moves upwards in the menus.
	(Right Arrow) Moves the cursor to the right.
	(Down Arrow) Decreases a displayed number value or step down in the menus.
	(Left Arrow) Moves the cursor to the left.

**Table 1 Function of the keys**

### 1.3 Changing the Operating Language

The operating language is currently offered in English only.

### 1.4 Keypad Lock

The controller has an available keypad lock. If the keypad lock is enabled, access requires a passcode. The keypad password is the same as the password used in the Ethernet or Wi-Fi browser connection.

See [11.2.2 Keypad Passwords](#)

## 2 Navigating the [Menu] display

Name of menu item	Jump to chapter
[Home]	↩ Return to the default display (See below)
[Adjust Set-points]	↩ Chapter 10.6.2 Feed Based on a Sensor
[Prime, Force ON]	↩ Chapter 10.14 Prime, Force On a Relay
[Water Meter Setup]	↩ Chapter 9.10.1 Configure a Digital Input as a Water Meter
[Adjust Alarms]	↩ Chapter 9.8.1 Analog Alarm Configuration
[Biotiming, Events]	↩ Chapter 10.7 Configuring an Event-Other relay
[Set Feed Mode]	↩ Chapter 10.6 Configuring a Feed Relay
[Set Blowdown Mode]	↩ Chapter 10.5 Configure a Blowdown Relay
[I/O Setup]	↩ Chapter 9.1 Analog and Digital Inputs
[I/O Status]	↩ Chapter 10 Programming the Control Outputs Use this menu choice to monitor the I/O
[System]	↩ Chapter 11 System Menu

Table 2 Main Menu lookup



Figure 4 Typical default screen



Figure 4A Screen if any alarm present

The default display exhibits up to six current sensor values, and STATUS, ALARM and SETPNT buttons. The sensor choices can be changed or rearranged. See section [2.2 How to Modify the Display's 'Home' Screen](#). The STATUS button (F1) is explained in section [2.1 Input/Output Status](#). The Alarm button (F2) allows the user to view and clear the latest alarms for all I/O points. See also section [9.8.1 Analog Alarm Configuration](#), for more information on alarms.

The SETPNT button (F3) allows the user to edit the set-point of any enabled relay using set-points.

# Menu Navigation

## 2.1 Input/Output Status [momentary display]

- 1- From main display press Down arrow key to select desired sensor
- 2- Use Right arrow key to momentarily see sensor information
- 3- Use Left arrow key to momentarily see any output that is tied to the selected input
- 4- Use **ESC** key to Exit

**Note:** The momentary information will remain on the display as long as you hold down the arrow key

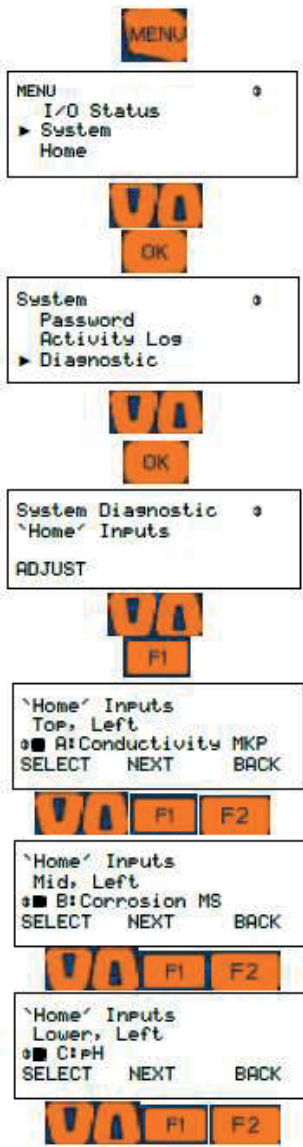
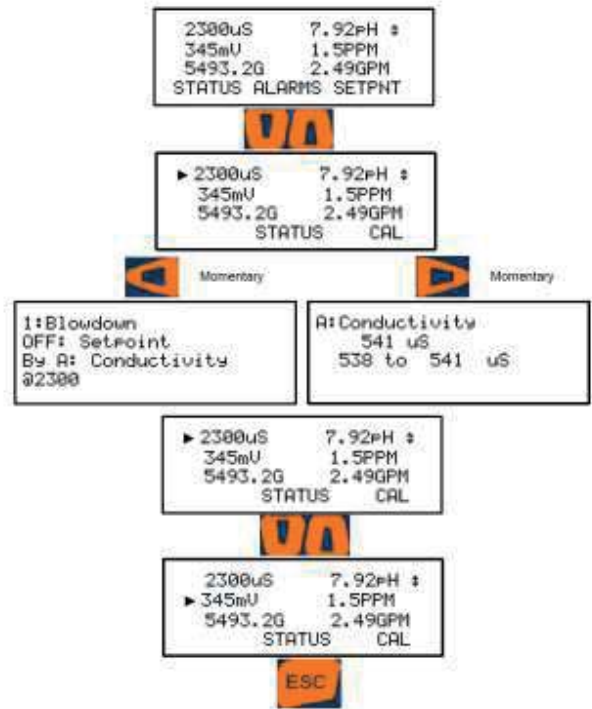

## 2.2 Modifying the 'Home' Screen

- 1- To set (modify) the Home Screen press **MENU**
- 2- Use Up/Down Arrows to navigate to System then press **OK**
- 3- Scroll to Diagnostic then press **OK**
- 4- Scroll to System Diagnostic then press **F1, ADJUST**
- 5- Use UP/Down Arrow keys to select what to display on Top, Left OLED Screen (maximum of six parameters can be displayed on OLED) then press **F1 SELECT**, you should see a square box appear in front of your selection.
- 6- Press **F2, NEXT**. "Mid, Left" should appear on the screen, use UP/Down Arrow keys to select what to display in the middle row, left position, then press **F1, NEXT**, you should see a square box appear in front of your selection
- 7- Continue the process for the four remaining choices, if desired.
- 8- Press **ESC** (Escape) when done.



### 3 Identcode

All ProMinent products use an identification code (Identcode) product configuration system. The Identcode is an alpha-numeric string of characters, starting with a 4 digit code describing the basic product type, followed by as many digits as needed to describe all options. The 4 character designation for the Aegis II is AGIb. All Aegis II configurations begin with AGIb. (The original Aegis identcodes start with AGIa.)

Table 3 Product Identification Code for the Aegis II

DULCOMETER®, AEGIS II Cooling Tower and Boiler Controller	
AGIb	Version
US	North America
EU	Europe
	<b>Execution</b>
00	with PM-logo
01	without PM-logo
	<b>Operation Voltage</b>
6	100 - 240 V, 50/60 Hz
	<b>Communication Interface</b>
LO	LAN
LB	LAN+Bluetooth (not currently available. Jan 2017)
W0	LAN+WLAN/WiFi
BW	LAN+WLAN/WiFi+Bluetooth (not currently available. Jan 2017)
	<b>Application pre-setting</b>
00	none
B0	Boiler factory configuration
T0	Cooling tower factory config.
T1	Cooling tower 1 Bio 1 Inhib
T2	Cooling tower 2 Bio 1 Inhib
P1	Polymer dosing
A1	Ammonia measurement
P0	Pool
	<b>Serial sensors input A</b>
00	none
ST	Tower CTF
CM	Adm.corr.sens.CRS-AM
CC	Carbon steel corr.sens.CRS-CS
CU	Copper corr.sens.CRS-CU

# Identification Code

CN	Copper-nickel corr.sens.CRS-CN
CS	Stainl.steel corr.sens.CRS-SS
	<b>Serial sensors input B</b>
00	none
ST	Tower CTF
CM	Adm.corr.sens.CRS-AM
CC	Carbon steel corr.sens.CRS-CS
CU	Copper corr.sens.CRS-CU
CN	Copper-nickel corr.sens.CRS-CN
CS	Stainl.steel corr.sens.CRS-SS
	<b>Expansion Slot #1 (input C/D)</b>
00	none
BM	dual boiler cond w/bd rel
B2	dual boiler cond - monitor
BB	condensate cond/temp - relay
CC	condensate cond/temp - monitor
CO	cooling tower cond/temp - rel
CM	cooling tower cond/temp - mon
PP	dual cooling tower ph - con
P2	dual cooling tower ph - mon
RR	dual orp - control
O2	dual orp - monitor
OP	orp and ph - control
MM	orp and ph - monitor
DC	dual corrosion rate
I1	dual 4-20ma in (isolated) 1con
I3	dual 4-20mA in (isolated) 2con
I4	dual 4-20mA in (isolated) mon
OO	dual 4-20ma output
SS	Serial sensor module
MA	mV/temp. + mA module
	<b>Expansion Slot #2 (input E/F)</b>
00	none
BM	dual boiler cond w/bd rel
B2	dual boiler cond - monitor
BB	condensate cond/temp - relay
CC	condensate cond/temp - monitor

Identification Code

CO	cooling tower cond/temp - rel
CM	cooling tower cond/temp - mon
PP	dual cooling tower ph - con
P2	dual cooling tower ph - mon
RR	dual orp - control
O2	dual orp - monitor
OP	orp and ph - control
MM	orp and ph - monitor
DC	dual corrosion rate
I1	dual 4-20mA in (isolated) 1con
I3	dual 4-20mA in (isolated) 2con
I4	dual 4-20mA in (isolated) mon
OO	dual 4-20ma output
SS	Serial sensor module
MA	mV/temp. + mA module
	<b>Expansion Slot #3(input I/J)</b>
00	none
BM	dual boiler cond w/bd rel
B2	dual boiler cond - monitor
BB	condensate cond/temp - relay
CC	condensate cond/temp - monitor
CO	cooling tower cond/temp - rel
CM	cooling tower cond/temp - mon
PP	dual cooling tower ph - con
P2	dual cooling tower ph - mon
RR	dual orp - control
O2	dual orp - monitor
OP	orp and ph - control
MM	orp and ph - monitor
DC	dual corrosion rate
I1	dual 4-20ma in (isolated) 1con
I3	dual 4-20mA in (isolated) 2con
I4	dual 4-20mA in (isolated) mon
OO	dual 4-20ma output
SS	Serial sensor module
AM	Aquatic module, only slot #3
PM	Pyxis module, only slot #3

# Identification Code

MA	mV/temp. + mA module
<b>Pump output type (PN)</b>	
0	Relays no preset
P	Powered(115/230V) relay(R1+R2)
V	Var.frequency contact (P6 to P9)
X	Combination of P+V
<b>Pre-wired power relay plugs</b>	
0	none (e.g.European vers.)
1	one - US version - 115V
2	two - US version - 115V
3	three - US version - 115V
4	four - US version - 115V
5	five - US version - 115V
<b>Pre-wired power rel.box/output</b>	
0	none (e.g.European vers.)
<b>Outputs inhibitor/Boiler feed</b>	
0	None
1	One
2	Two
<b>Biocide Outputs</b>	
0	none
1	one
2	two
3	three
	Hardware extension
0	without
<b>Approval</b>	
00	UL / MET / CSA
01	CE
<b>Documentation Language *future*</b>	
DE	German
EN	English
ES	Spanish
FR	French
BG	Bulgarian
CS	Czech
DA	Danish

Identification Code

ET	Estonian
EL	Greek
FI	Finnish
HR	Croatian
HU	Hungarian
IT	Italian
JA	Japanese
KO	Korean
LT	Lithuanian
LV	Latvian
NL	Dutch
PL	Polish
PT	Portuguese
RO	Romanian
SK	Slovakian
SL	Slovenian
SR	Serbian
SV	Swedish
RU	Russian
TH	Thai
TR	Turkish
ZH	Chinese

Table 3 Product Identification Code for the Aegis II

## 4 Safety and Responsibility

### 4.1 Explanation of the safety information

#### Introduction

These operating instructions provide information on the technical data and functions of the product, as well as detailed safety information and are provided as guidance for the installer and operator.

The safety information and notes are categorized according to the following scheme. A number of different symbols are used to denote different situations.

The symbols shown here serve only as examples.



Denotes hints on use and other useful information.

**NOTICE**

Denotes a possibly damaging situation. If this is disregarded, the product or an object near it could be



**⚠ DANGER**

Hazardous voltages cause severe injury or death.  
Disconnect all sources of power before servicing.  
(Multiple and/or remote sources of power may be present).



**DANGER!**

Denotes an immediate threatening danger. If this is disregarded, it will result in very serious or fatal injuries.



**WARNING!**

Denotes a hazardous situation. If this is disregarded, it could result in very serious or fatal injuries.



**CAUTION!**

Denotes a possibly hazardous situation. If this is disregarded, it could result in slight or minor injuries. May also be used as a warning about equipment damage.

4.2 General Safety Notes

- ❖ Measure: Before opening the enclosure or before carrying out installation work, ensure the devices are voltage-free.
  - ❖ Disconnect damaged, defective or modified devices from the power supply.

 **WARNING!**  
 Live parts!  
 Possible consequence: very serious or fatal injuries

**NOTICE**

Correct sensor operation

Damage to the product or its surroundings.

- Correct measuring and metering is only possible if the sensors are working correctly.
- Check, clean and calibrate the sensors regularly
- Investigate all alarm conditions.

 **WARNING!**  
 Danger from hazardous substances!  
 Possible consequence: Fatal or very serious injuries.

Please ensure when handling hazardous substances that you have read the latest safety data sheets provided by the manufacture of the hazardous substance. The actions required are described in safety data sheets.

Check safety data sheets regularly and replace, if necessary, as the hazard potential of a substance can be re-evaluated at any time based on new findings.

The system operator is responsible for ensuring that up to date safety data sheets are available, as well as for producing an associated hazard assessment for the workstations affected.

 **WARNING!**  
**Operating faults!**  
 Possible consequence: Fatal or very serious injuries.

The unit should only be operated by adequately qualified and technically expert personnel

Please also observe the operating instructions for sensors and fittings and any other units which may be installed, such as sample water pumps

The operator is responsible for ensuring that personnel are qualified.

 **DANGER**  
 Hazardous voltages cause severe injury or death.  
 Disconnect all sources of power before servicing.  
 (Multiple and/or remote sources of power may be present).

 **CAUTION!**

Read all installation and operating instructions completely before installing and operating this equipment

---

## Safety and Responsibility

---

### 4.3 Intended Use

The device is intended for measuring and regulating liquid media in industrial and municipal water treatment applications.

Only use the device in accordance with the technical data and specifications outlined in these operating instructions and in the operating instructions for the individual components (such as sensors, fittings, calibration devices, metering pumps, etc.).

Any other uses or modifications may void the ProMinent warranty.



### CAUTION!

If the equipment supplied is used in a manner not specified in these instructions, protection provided by the equipment may be impaired.



### CAUTION!

The pertinent accident prevention regulations, as well as all other generally acknowledged safety regulations, must be adhered to!

### 4.4 Warranty Guide

As of this date, the physical controller is warranted for 2 years from the date of purchase as explained in the complete Prominent warranty. The complete warranty is found in the Prominent catalog Introduction and is available online at [www.prominent.us](http://www.prominent.us). Changes to this warranty may not be shown in this manual.

Sensors are typically warranted for 8 months.

The warranty does not apply to goods that become defective for the reason of:

- a) Unsuitable or unreasonable use
- b) Faulty assembly, installation or servicing by the purchaser or any third party
- c) Faulty or careless handling

### 4.5 Users' Qualifications



### WARNING!

Danger of injury to inadequately qualified personnel!

The operator of the plant / device is responsible for ensuring that the qualifications are fulfilled.

If inadequately qualified personnel work on the unit or loiter in the hazard zone of the unit, this could result in dangers that could cause serious injuries and material damage.

All work on the unit should therefore only be conducted by qualified personnel.

### CAUTION!



Symbol will be applied beside each MAINS socket outlet and identifying that the maximum total output current rating on all relays should not exceed 5A



4.5.1 Training

Training	Definition
Instructed personnel	An instructed person is a person who has been instructed and, if required, trained in the tasks assigned to him/ her and possible dangers that could result from improper behavior, as well as having been instructed in the required protective equipment and protective measures.
Trained user	A trained user is a person who fulfills the requirements of an instructed person and who has also received additional training specific to the system from ProMinent or another authorized distribution partner.
Trained qualified personnel	A qualified employee is deemed to be a person who is able to assess the tasks assigned to him and recognize possible hazards based on his/her training, knowledge and experience, as well as knowledge of pertinent regulations. The assessment of a person's technical training can also be based on several years of work in the relevant field.
Electrician	<p>Electricians are deemed to be people, who are able to complete work on electrical systems and recognize and avoid possible hazards independently based on his/her technical training and experience, as well as knowledge of pertinent standards and regulations.</p> <p>Electricians should be specifically trained for the working environment in which they are employed and know the relevant standards and regulations. Electricians must comply with the provisions of the applicable statutory directives on accident prevention.</p>
Customer Service department	Customer Service department refers to service technicians, who have received proven training and have been authorized by ProMinent to work on the system.

Table 4 Training Definitions

## 5 Functional Description

The DULCOMETER® AEGIS II is a Multi-parameter control and analysis platform from ProMinent. In the remainder of this document, the term 'controller' is consistently used for the DULCOMETER® AEGIS II. The controller has been developed for continuous measurement and control of liquid analysis parameters in water treatment processes in industry. The controller can operate together with conventional analog and digital sensors and actuators. The controller is also equipped to communicate with some sensors using a proprietary serial bus.

The controller relays may be used with solenoids, chemical metering pumps and related water treatment equipment, not to exceed 1 amp each. (Typical)

Typical applications:

- Cooling water treatment
- Data and event logger
- Boiler water treatment
- Industrial process water treatment
- Potable water treatment
- Waste water treatment
- pH and/or temperature compensation for free chlorine measurement

Standard equipment:

- Two serial input channels for use with CTFS (Conductivity/ Temperature/Flowswitch Serial), dual serial corrosion rate sensors or DP (differential Pressure) sensors.
- Eight multi-purpose digital inputs (2 NAMUR - Intrinsically safe<sup>1</sup>) for turbine and contact water meters and limit switches.
- One 4-20mA analog input
- One analog temperature input.
- Temperature compensation for the pH and conductivity sensor signals.
- Output Relays: On-Off, Time Modulated (Pulse Width Modulation) or PID controller using any/all of the following: line voltage relays(2), unpowered 'dry' contacts(3), or Solid State DC contacts(4).
- Currently, 1 operating language
- Saving and transfer (cloning) of controller configuration via USB.
- Upgrading of the firmware function using USB Flash Drive
- Ethernet LAN connection for remote operation or configuration

Optional accessories:

- Up to 3 dual sensor input/output driver cards including:  
Dual pH/ORP, Single pH/ORP with temperature and 4-20mA input, Boiler Conductivity, Conductivity/Temperature, Dual 4-20mA Output, Dual 4-20mA input or a Dual Serial Input driver.
- A full line of ProMinent sensors as well as signals from most 4-20mA devices are compatible with the 4-20mA input. Sensors include: Chlorine, Bromine, Peracetic Acid (PAA), Toroidal Conductivity and fluorometers.
- 1 Expansion card slot for future use
  - 1 Fluorimeter sensor input (future)
  - 1 Modbus-RTU port (future)
  - 1 Additional 10mV/°C Temperature Sensor (future)
  - 1 Analog input (4-20mA)
  - 2 Analog outputs (4-20mA)
- Wi-Fi WLAN web access



### I/O Naming structure

The Aegis II controller inputs are assigned letters and the outputs are assigned numbers as part of the programming scheme. This allows, for example, output relay 3 to be controlled by input sensor E, Chlorine. The Chlorine sensor must be input on E and the hypochlorite pump must be plugged into R3.  
4-20mA outputs are the only signals that do not follow this plan. They are labeled C1, C2, etc.

Foot note 1

Namur Input Data

Passive amplifier passive to Namur:  
(DIN19234-> EN60947-5-6)

Power supply: 8,2V / 1kOhm (proximity sensor)  
High: 2.2mA..6.5mA  
Low: 0.4mA..1.1mA  
Operating range: 1.2mA..2.1mA (not continuous)  
Switching current diff :: 0.2mA (input constant)  
H / L threshold: 1.6mA  
(Fraction: <0.2mA)

## 6 Mounting and Installation

User qualification, mechanical installation: trained qualified personnel, see ↗ Chapter [4.4 Users' qualifications](#).

User qualification, electrical installation: Electrical technician, see ↗ Chapter [4.4 Users' qualifications](#).



### CAUTION!

Controller must be installed in a manner that the power plug can be pulled out easily or the power disconnect switch can be reached easily.



### Mounting position

- Install the Aegis II at eye level to make operation easiest
- The controller is wall-mounted as standard.
- Always install the controller horizontally, so that the cable entries are facing downwards.
- Leave sufficient free space for cables and access to any sensors or sample plumbing mounted below.

### NOTICE

#### Mounting position and conditions

The controller is rated for IP 65 liquid protection, and is equivalent to NEMA 4X (indoor) for air tightness. These standards are only achieved if all seals and threaded connectors are correctly rated and installed.

Electrical installation should only be performed after mechanical installation.

Ensure that there is unimpeded access for operation

Secure, low-vibration installation

Avoid direct sunlight

Permissible ambient temperature of the controller at the installation location: -20 to 60°C (-4 to 140°F) at max. 95% relative air humidity (non-condensing)

Take into consideration the permissible ambient temperature of the connected sensors and other components.

The controller is only suitable for operation in closed rooms. If operated outside, the controller must be protected against the environment by a suitable protective enclosure

All above conditions apply at or below an altitude of 2,000 meters.

## Scope of Supply

### 6.1 Scope of supply

The following components are included as standard:

Description	Quantity
Controller AGIb	1
Assembly material, complete	2
Operating Manuals on Flash Drive	1
General safety notes	1

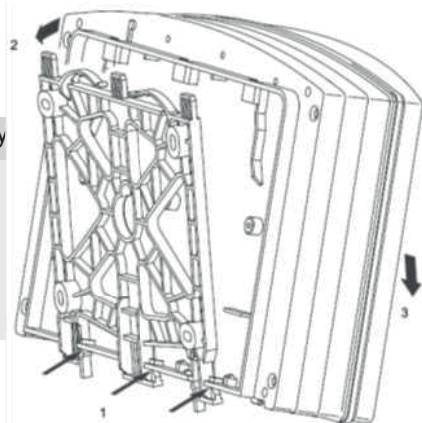

Figure 5 Attaching the wall Bracket

### 6.2 Mechanical installation

#### 6.2.1 Wall mounting

Mounting materials (contained in the scope of supply)

- 1 x wall bracket
- 4 x PT screws 5 x 35 mm
- 4 x washers 5.3
- 4 x wall anchors Ø 8 mm, plastic

Wall mounting

1. Remove the wall bracket from the housing
2. Press the two snap hooks (1) outwards
  - ⇒ The wall bracket snaps slightly downwards.
3. Push the wall bracket downwards (2) to clear the housing and tilt it out (3)
4. Use the wall bracket as a drilling template to mark the positions of 4 drill holes.
5. Drill the holes: Ø 8mm (5/16"), depth = 50mm (1.96")

1. Screw the wall bracket into position using the washers provided. If needed, use the wall anchors provided.
2. Hook the bottom of the housing (1) into the wall bracket
3. Lightly press the housing at the top (2) against the wall bracket
4. Then check that the housing is hooked in at the top and press down (3) until it clicks into place.

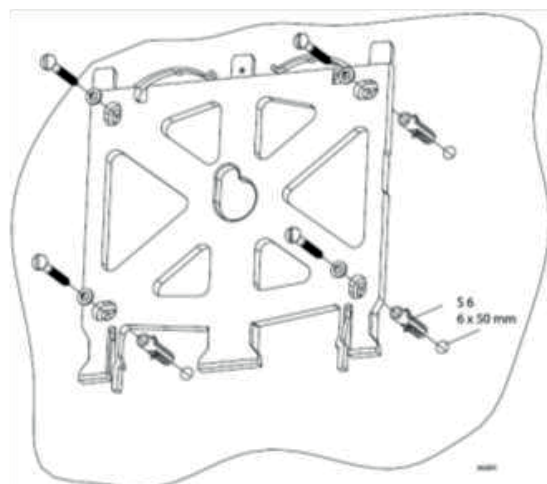
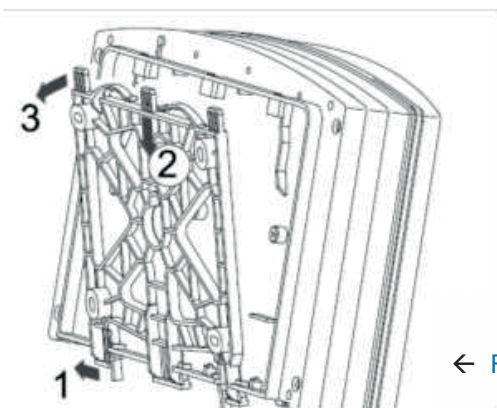

↑ Figure 7 Mounting the Wall Bracket

← Figure 6 Removing the wall Bracket

### 6.3 Electrical Installation

User qualification, electrical installation Electrical technician, see ↗ Chapter [4.4 Users' qualifications](#)

#### **NOTICE**

##### Moisture at the contact points

It is important that you use suitable measures to protect plugs, cables and terminals from moisture and potential corrosion. Moisture at the contact points can interfere with the operation of the controller.



#### **WARNING!**

##### Safe operating status

Both hardware and software safety precautions must be taken to ensure that the Aegis II adopts a safe operating condition in the event of a fault.

Use limit switches, mechanical locks, and other appropriate safety devices.

During installation the device must not be electrically live.

The installation must only be carried out by technically trained personnel.

# Mounting and Installation

## 6.3.1 Specification of the cable grips and conduit entries

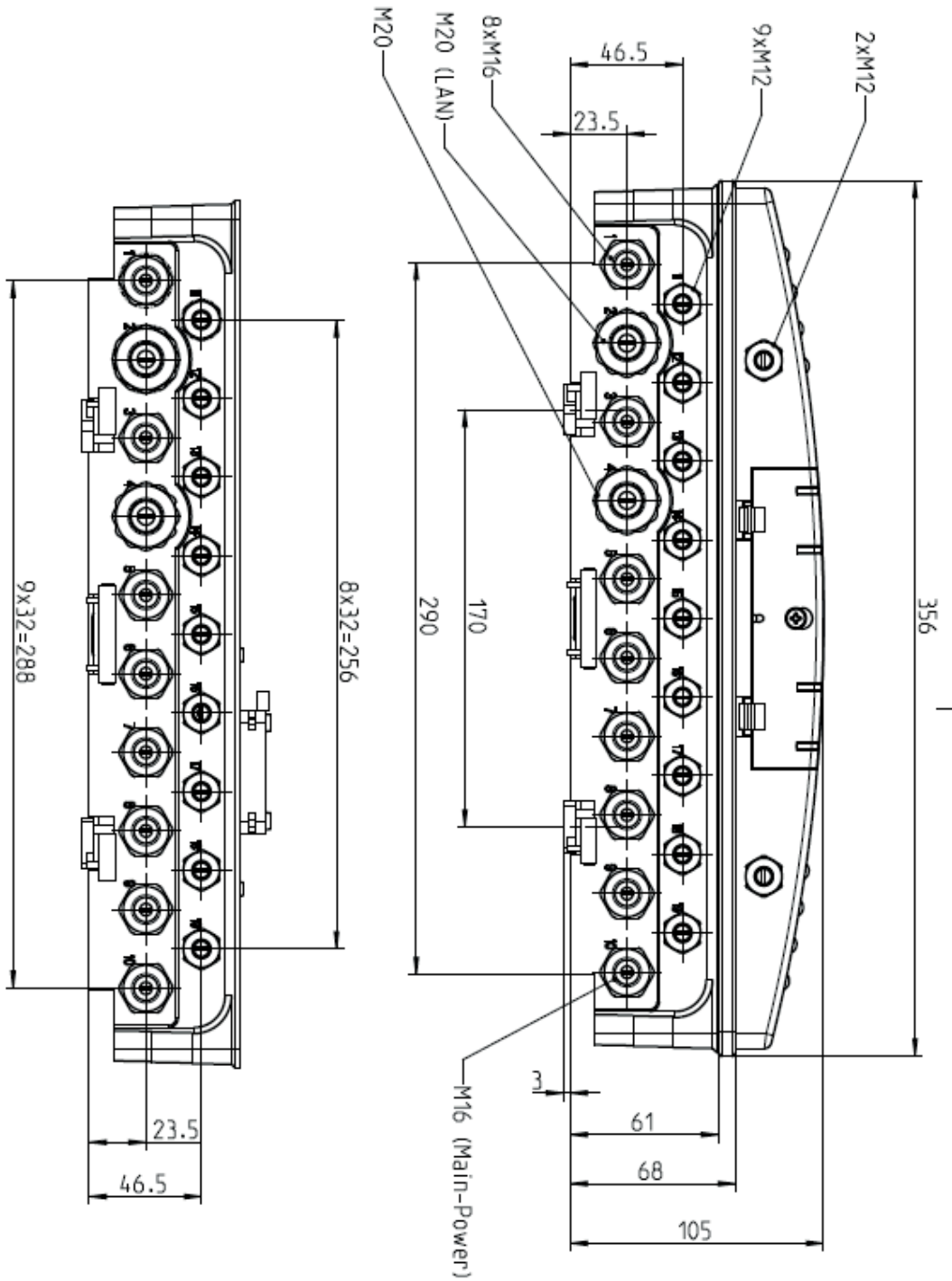

Figure 8 All Dimensions in millimeters (mm)

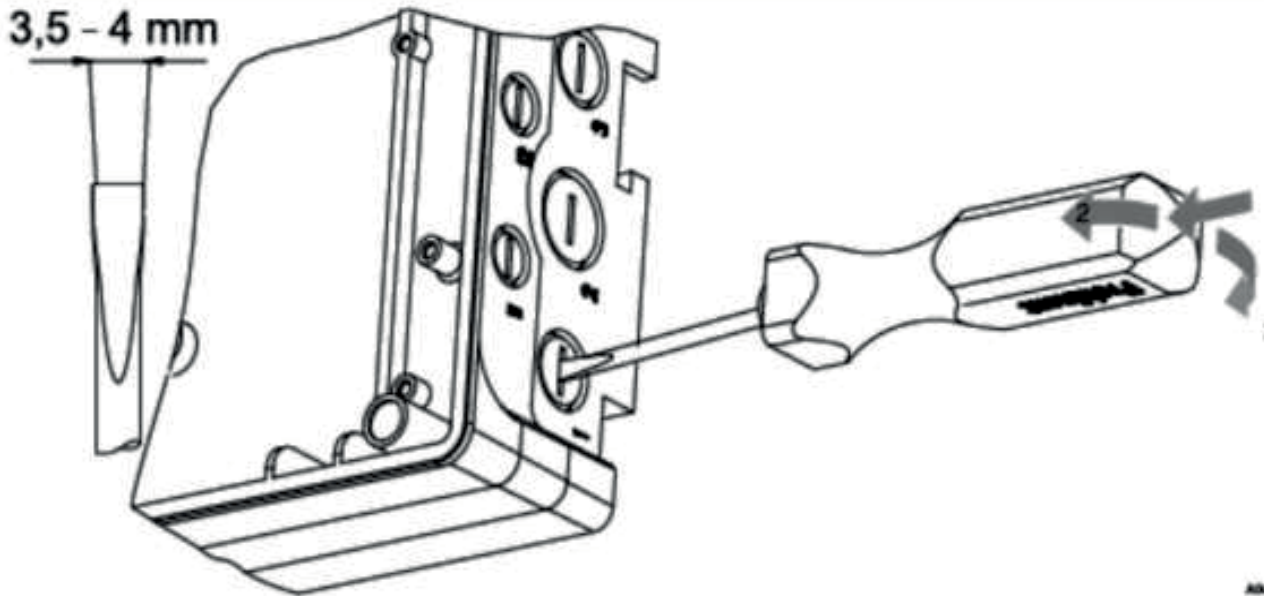

Figure 9 Use a screwdriver to break open a sealed enclosure entrance

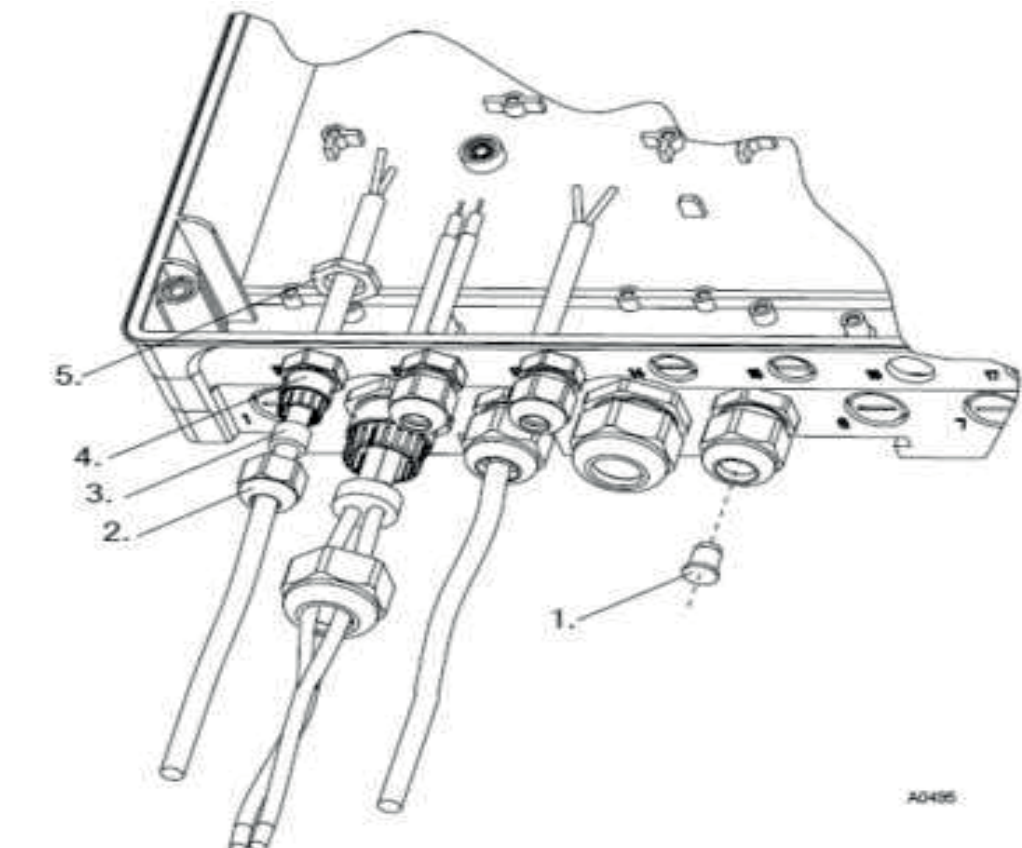

Figure 10 Examples of cable gland assembly.  
1. Plug, 2. Cap, 3. Gland, 4. Connector Body, 5. Nut

### 6.3.2 Sensor Seals and Termination Procedure

Select the correct fitting seals for the controller's cable openings. Seal the open holes with blanking plugs in the cord glands as shown. This is the only way to ensure an acceptable air and moisture seal. Non-sealing dust caps are not effective for preventing non-warranty damage from moisture, corrosion or insects.

## Mounting and Installation

### 6.3.3 Parking the Hood

The hood or cover of the Aegis II enclosure can be 'parked' so that access to the internal wiring and all of the display indications are accessible simultaneously as shown below. To park the hood, loosen the four captive screws until the hood can be carefully pulled straight out from the enclosure base. Note the plastic brackets attached to both sides of the lower portion of the hood, and the slots they were removed from. Notice identical slots higher on the base that the hood can be inserted into. Carefully insert the brackets into the slots until they click and seat.

- Guide the cable into the controller.
- Connect the cable as indicated on the terminal diagram
- Tighten the clamping nuts of the threaded connections so that they are properly sealed
- Place the upper section of the housing onto the lower section of the housing. Check for wires on the perimeter
- Manually tighten the housing screws
- Check once again that the seal is properly fitted. The degree of protection IP 65 can only be assured if the cover mounting is correct.



Figure 11 Hood in the parked position



Ensure that wires are not under tension when wiring is completed.

### NOTICE

As with most electronic devices, moisture in the controller can lead to operational abnormalities and damaging corrosion. Note the instructions on the terminal diagrams provided.

### 6.3.4 General Layout and Terminal Diagrams

Figures 12 through 15 show general position of electronic components and wiring terminations.

Figure 12 shows the position of the internal relay indicators for each relay R1 through R9. These lights are repeated on the controller cover.

Figures 16 and 17 are electrical schematics of the I/O.

Section 6.3.5 depicts wiring rules and examples.



Figure 12 Internal Relay Indicator LEDs



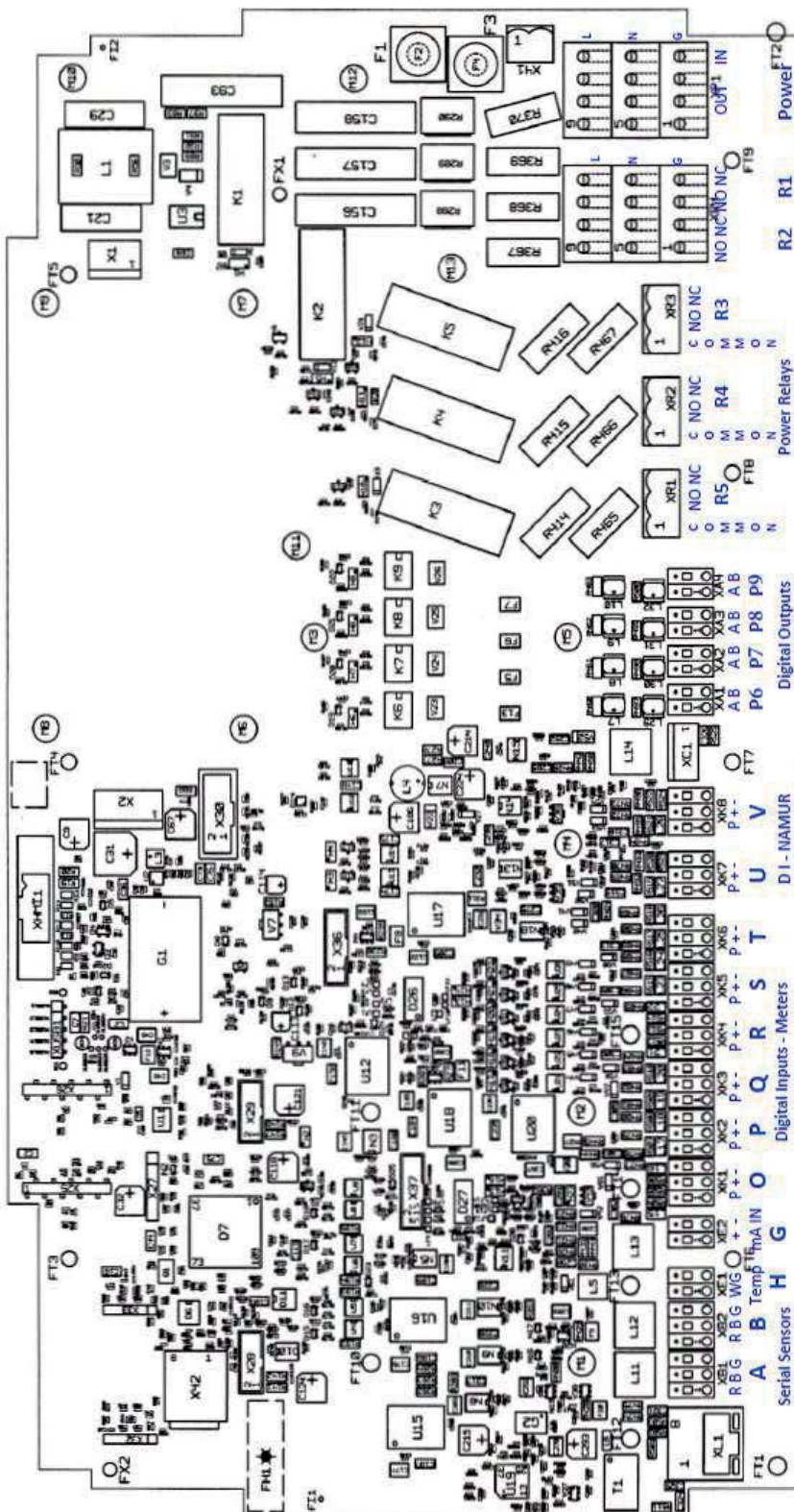

- Building Power In
- Line Power out x3
- AC powered Control Relay R1
- AC powered Control Relay R2
- Unpowered AC/DC Relay R3
- Unpowered AC/DC Relay R4
- Unpowered AC/DC Relay R5
- Unpowered DC Contact P9
- Unpowered DC Contact P8
- Unpowered DC Contact P7
- Unpowered DC Contact P6
- Digital Input V (NAMUR) – Intrinsically safe
- Digital Input U (NAMUR) – Intrinsically safe
- Digital Input T
- Digital Input S
- Digital Input R
- Digital Input Q
- Digital Input P
- Digital Input O
- 4-20mA Input G
- Temperature Input H
- Serial Input B (CTFS / LogR / other)
- Serial Input A (CTFS / LogR / other)

Figure 13 I/O Terminal Arrangements and Callouts

# Mounting and Installation

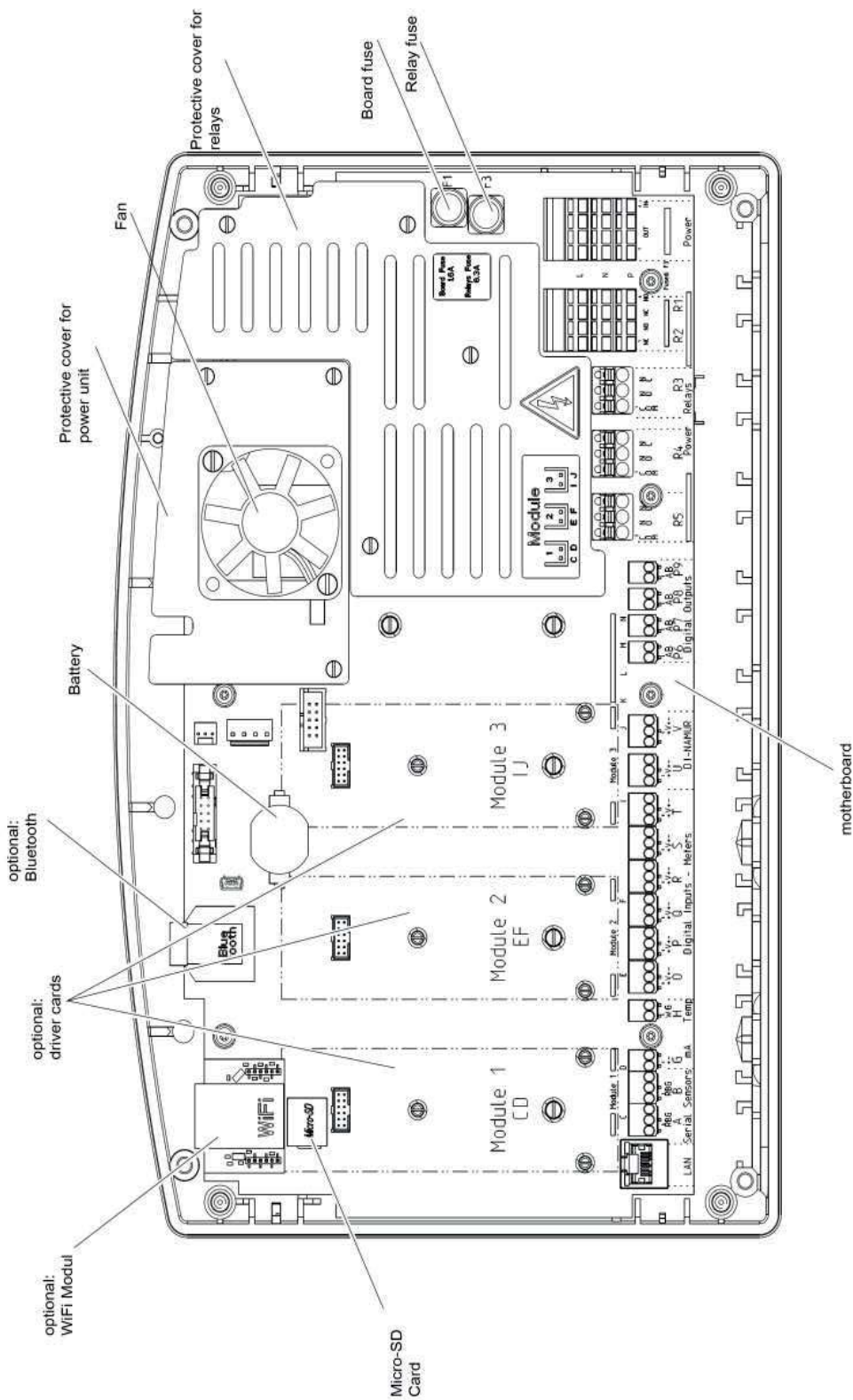

Figure 14 Aegis II overall location of major components

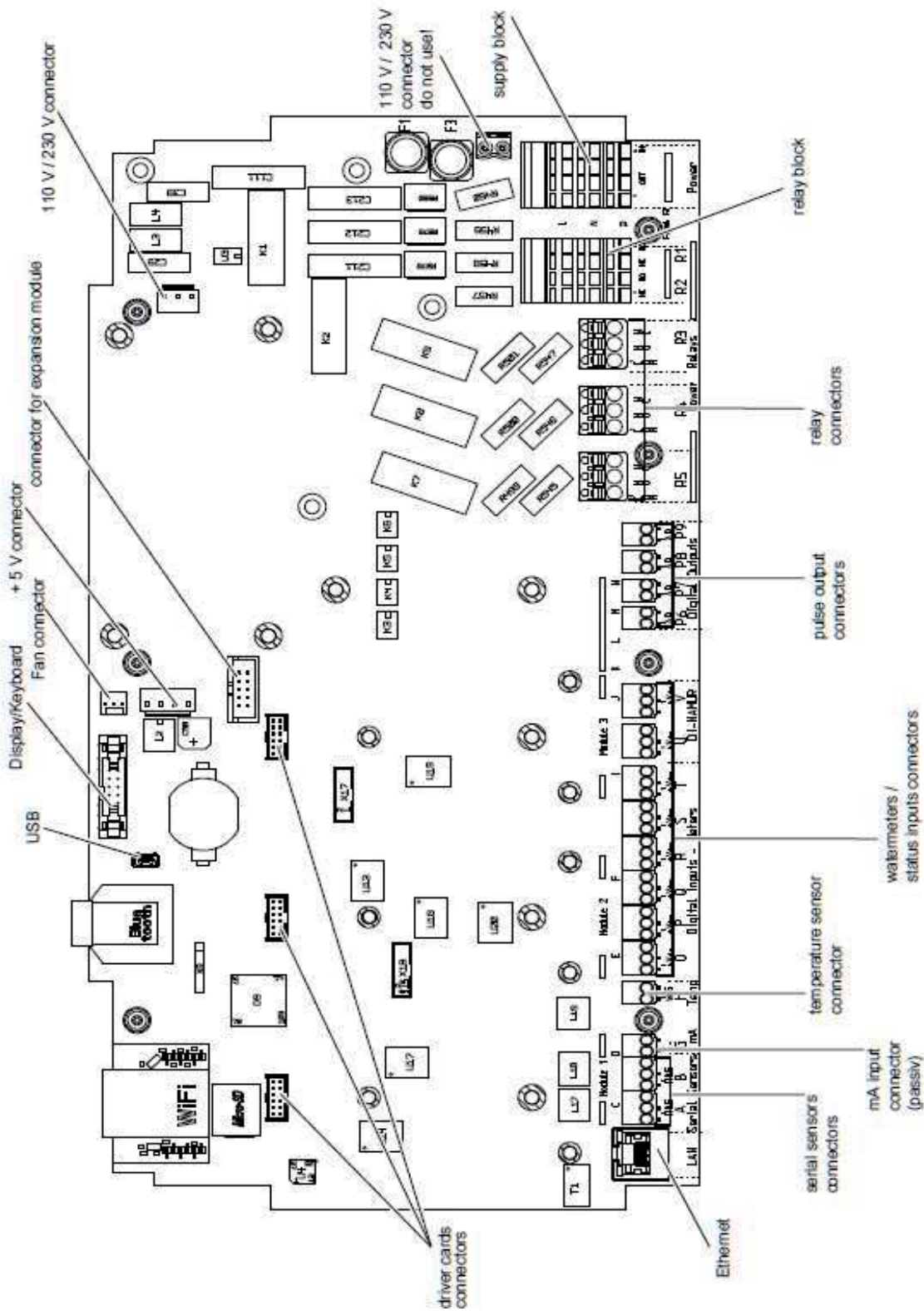

Figure 15 Agis II motherboard general arrangement

# Mounting and Installation

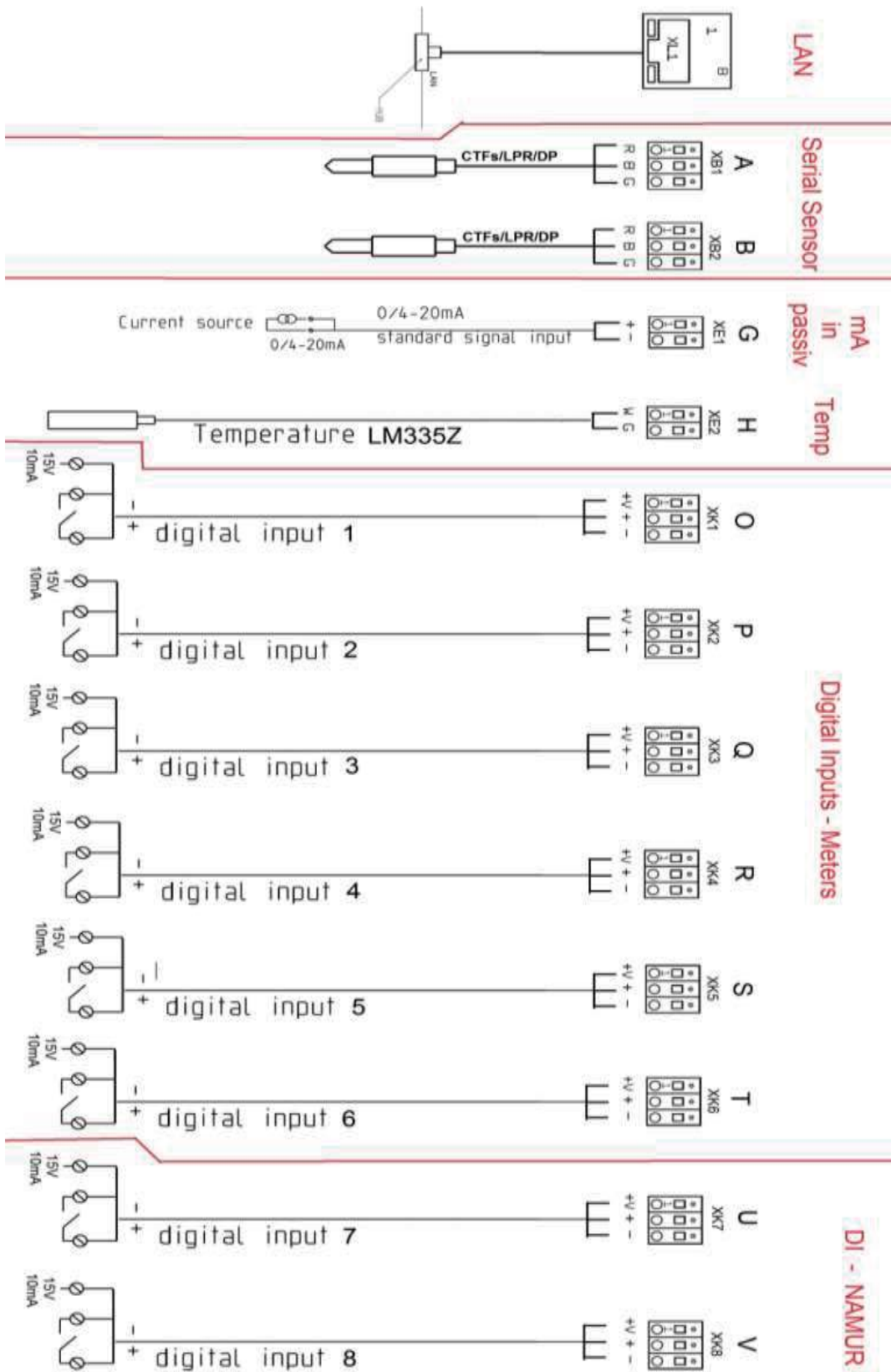

Figure 16 Main PC board Input Wiring diagram

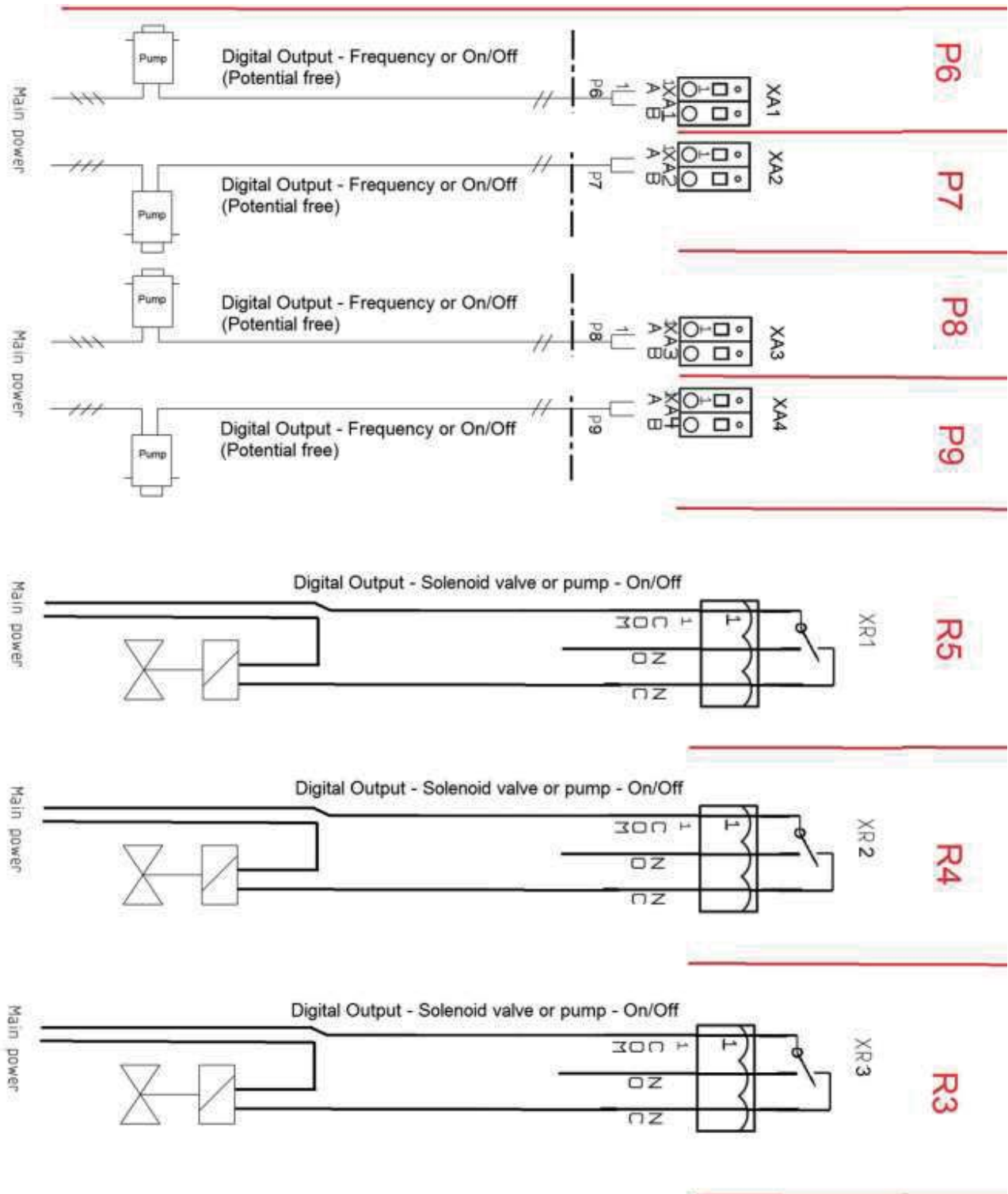

Figure 17A Main PC board Output Wiring diagram; Part 1: Relays R3 through P9

## Mounting and Installation

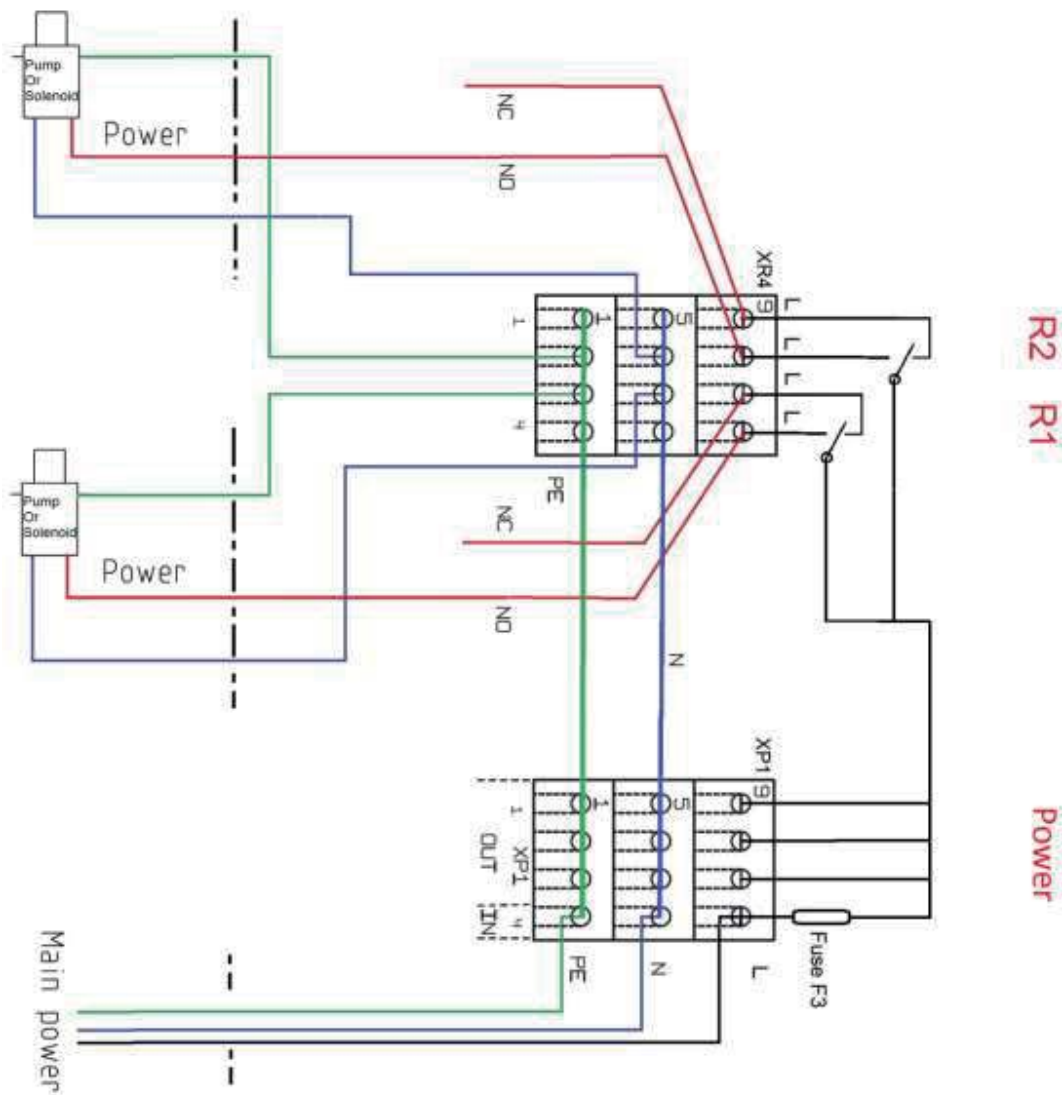

Figure 17B Main PC board Output Wiring diagram; Part 2: Relays R1, R2 and the Power block

The ground and neutral connections are all tied together through the printed circuit board as shown in the schematic 17B. The hot (Line) wire does not link with the other L terminals until after it passes through the main fuse F3.

Main power is terminated on the bottom rung of the Power block marked IN in figure 17C.

See section [6.3.5 Power In and Relay Output Termination](#)



Figure 17C Relays R1, R2 and the Power block

## 6.3.5 Power In and Relay Output Termination

All electrical wiring shall be performed by a licensed electrician, in accordance with local and national electric codes.



The following wiring diagrams and information show typical configurations, but not all possible combinations of this versatile controller.

### 6.3.5.1 Overview

The power/relay section of the controller is shown in Figure 18 without wiring. Here we can see the labels on the controller circuit board indicating (from **right to left**) power in, power out and relays R1 through R5. See also figures 17B and 17C.

The two large orange terminal blocks on the right each have 3 levels; **Line**, **Neutral** and **Ground (PE)**. Input power is connected to the right most row of this block. See Figure 20.

In the USA, this connection is prewired in the factory for use with 120VAC. However, the input power supply will accommodate 100 to 230VAC at 50 to 60 Hz. No controller adjustment is required. Use wire/cables/plugs that are matched to the power you are using. See also [6.3.6.4 Connecting a Power Cord](#).

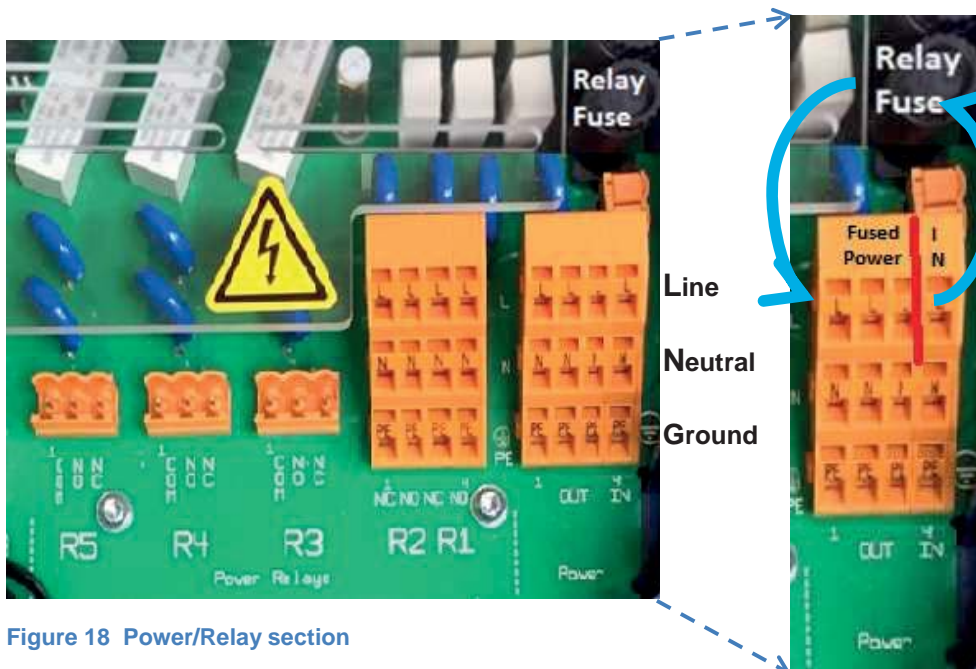

Figure 18 Power/Relay section

**Note:** The terminal connectors have been removed from relays R3, 4 and 5 for clarity. See them in Figure 23.

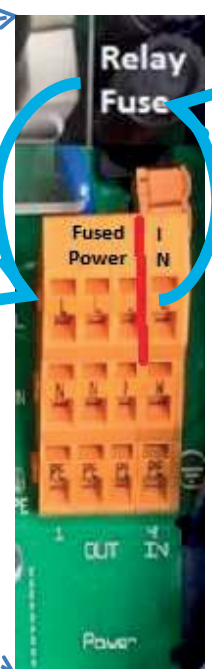

Figure 19 Power Block



Figure 20 Factory installed Power

Input power is fed through the circuit board to the Relay Fuse located above the Power block, then back to the Power block's three output terminals. (See Figure 19) The main circuit board under the Power block ties all 4 Neutrals together and all 4 PE (ground) terminals together. (See figure 17B)

The three fuse powered outputs can be used to power the dry contacts on relays R3, R4 and R5. See also figure 25.

Fused power is also connected to the common tips of R1 and R2. These relays are 'powered' relays. See Figure 17B

All 5 relays can be used for pumps and solenoids as well as motor operated valves (MOV). MOV terminations are explained in section [6.3.5.3 Wiring Relays R1 and R2 for a Motor Operated Valve](#), and section [6.3.5.5 Wiring Relays for Externally Powered Motor Operated Valves \(MOV\)](#).

## Mounting and Installation

To enter wires into the terminal blocks, (see figure 22) insert a small screwdriver or similar, into the spring box opening as shown, then push up on the driver handle. This will force the spring loaded metal slider downwards and open the wire grip below.



**These blocks accept a maximum of 14 gauge wire.**

To enter wires into the digital inputs and digital outputs, depress the spring loaded tab. See figure 21



**The orange output terminals accept a maximum of 12 gauge wire.**

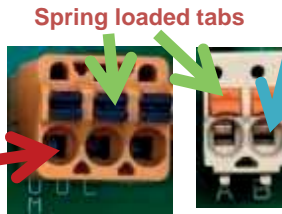

Figure 21 Spring loaded terminals

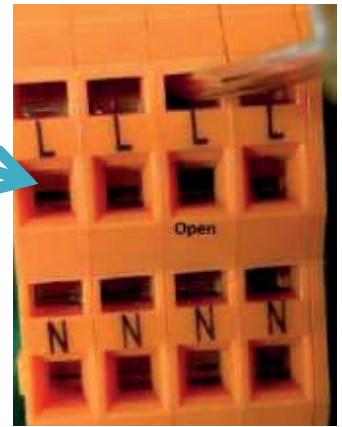

Figure 22 Open the terminals

### 6.3.5.2 Wiring Relays R1 and R2



## CAUTION!

**All electrical wiring shall be performed by a licensed electrician, in accordance with local and national electric codes.**

Figure 23 shows relays R1 and R2 wired to outlet plugs. (Plugs not shown). Notice that the black, white and green wires for R1 are in the right most column of the terminal block, the NO column. Relay R2 also utilizes the NO column. These plugs will supply power when the controller turns them on.

Powered relays R1 and R2 are designed to operate pumps and solenoids with a 1 amp rating or less. Relays R3, R4 and R5 can drive 5 amp devices. See section [6.3.5.5 Wiring Relays R3 – R5 Using an External Power Supply](#)



Figure 23 Terminating R1 & R2

### 6.3.5.3 Wiring Relays R1 and R2 for a Motor Operated Valve

Motor Operated valves typically have two hot wires, a neutral and a ground. The two hot wires will be terminated on the NO and NC terminals. The NO terminal will open the valve when the controller turns on the output relay. The NC terminal will close the MOV when the controller turns off the output. Figure 24 shows an MOV terminated on R1. The red wire is connected to R1 NO and the black wire is connected to R1 NC. See also section [6.3.5.6 Wiring Motor Operated Valves \(MOV\) to Relays R3 - R5](#)

### 6.3.5.4 Wiring Relays R3 – R5 Using On-board Power

Terminal connectors for R3, R4 and R5 can be removed from the PCB by pulling them up and off the pins on the PC board to make wiring easier, if you choose. Relays R1, R2 and the power block cannot be removed.



Figure 24 R1 MOV



## CAUTION!

The unpowered (DRY) relays R3, R4, and R5 are not fused and any external connection to these relay terminals will require additional circuit protection provided by the installer at the time of installation.

Failure to protect these circuits can cause non-warranty equipment damage and could pose a safety hazard.



Relays R3, R4 and R5 have Dry Contact terminals. Unlike R1 and R2, they have no power. This allows the user to supply power from a remote source or use power from the Output side of the power block.

In Figure 25, we show a jumper wire from the Fused Power output block Line terminal to the Com input on R3 – the left terminal. The NO terminal is used to power the outlet plug – Center terminal, also black wire. This wire joins the Neutral and Ground wires coming from the power block.



Figure 25 Wiring R3 using on-board fused power

### 6.3.5.5 Wiring Relays R3 – R5 Using an External Power Source



## CAUTION!

The unpowered (DRY) relays R3, R4, and R5 are not fused and any external connection to these relay terminals will require additional circuit protection provided by the installer at the time of installation.

Failure to protect these circuits can cause non-warranty equipment damage and could pose a safety hazard.

An external power source can be used on relays R3, R4 and R5. Figure 26 illustrates an external voltage connected to relay R5 at the COM terminal (black wire). A second wire (red) on the NO terminal is the switched output to a pump, solenoid, alarm light, etc. The neutral and ground wires are not terminated in the controller.



Figure 26 Using external power

### 6.3.5.6 Wiring Motor Operated Valves (MOV) to Relays R3 - R5

Motor Operated valves typically have two hot wires, a neutral and a ground. The two hot wires will be terminated on the NO and NC terminals. The NO terminal will open the valve when the controller turns on the output relay. Figure 27 shows internal power used on R3 and external power used on R5 to control an MOV.



Figure 27 Motor Operated Valves wired to R3 and R5

## Mounting and Installation

### 6.3.5.7 Connecting a Power Cord



### CAUTION!

All electrical wiring shall be performed by a licensed electrician, in accordance with local and national electric codes.

Remove a knock-out from the bottom of the controller and install the cord using a NEMA4/IP66 cord grip as shown in figure 28. See also Figures 9 and 10.

Terminate the line, neutral and ground wires as shown in figure 28. See also figure 22 in the overview section to open the terminations.

### 6.3.6 Frequency Output Termination

Outputs 6 through 9 are unpowered digital outputs rated for 24VDC / 250mA which can be configured as a Pulse or ON/OFF output. See Figure 29.



Figure 29 Digital DC (Pulse) outputs 6-9

In pulse mode, these outputs can control the speed of pulse driven pumps. The frequency outputs vary the pump speed in much the same manner as a 4-20mA signal.

In the ON/OFF mode, the outputs will start or stop a pump. The pump frequency will then be determined manually at the pump.

#### 6.3.6.1 Using a Universal Control Cable on a Pulse Output Relay

Prominent pumps using the Universal Control cable will terminate using the brown, black and white wires as shown in Figure 30. This connection is not polarity sensitive. The black is common. The white is the pulse signal. The brown wire is for pause/enable. When the brown is not shorted to the black wire, the pump will be in pause mode.



Figure 28 Power cord



Figure 30 Universal Control Cable on Output Relay P6

### 6.3.7 Wiring sensors to the controller

#### NOTICE

Poor electrical connection may cause incorrect measurements. Once a wire is terminated, tug gently on the wire to ensure it is not loose.

Signal inputs to the controller attach to the main printed circuit board (PCB) or to expansion driver cards. Each input signal is assigned a letter, A through Z, for program identification. Analog outputs (4-20mA) are assigned an ID of C1 through C8. Digital outputs are assigned numbers 1 through 9.

In this way, outputs may be programmed to operate based on the status of specified inputs. Relay 3, for example, might be energized when sensor E reaches a programmed setpoint. Analog outputs (4-20mA) can be programmed to vary proportionally to an analog input in a forward or reverse direction. Refer to the Aegis Browser manual for programming detail.

#### 6.3.7.1 Inputs on the Main Board

The main PCB inputs are shown in Figure 31.

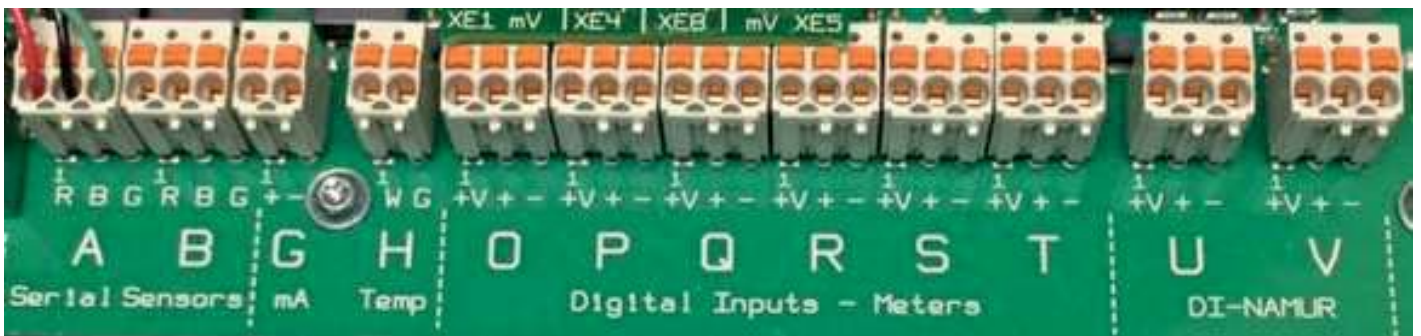

**Figure 31** Main board inputs

Inputs A and B are Prominent serial sensor inputs. Serial sensor choices currently include CTFS (Conductivity, Temperature, Flowswitch – Serial) and LogR serial corrosion sensors. These sensor have 3 wires; transmit, receive and common. Do not connect other probes to these inputs. Notice the color code of the wires is stenciled on the main board. The A input has a serial sensor attached to show the wire color matching the stencil; red, black and green.

Additional serial sensors may be added to the controller via expansion driver cards. See section

### NOTICE

The CTFS sensor is not the same as a CTF sensor. The CTF sensor is not serial and has 6 wires. The Aegis II uses the 3 wire CTFS sensor.

There are two types of corrosion rate sensors. The serial sensors have 3 wires. See the Spare Parts section for a list of compatible sensors

#### 6.3.7.2 The G input (4-20mA)

The G input is for 4-20mA devices. This includes analog tank level, flow rate, temperature, analyzer signals, PLC signals, etc. The G input is not programmed for Prominent amperometric sensors including pH and ORP sensors that have been converted to 4-20mA. This input is not used for Pyxis or Little Dipper sensors as well. All of these sensors require the 4-20mA expansion input card covered in the next section.

The 4-20mA loop input at G can be powered by the Aegis II controller or from the signal source. Figure 32 shows examples of both.

In both examples, the red wire is the + and the black wire is the -. The on-board power example shows us acquiring loop power from the O input. Any unused digital input can be used. The red + wire is connected to the power +V on the O input. The black - wire connects to the + input of G. A jumper (white) is used to complete the loop from the power - on O to the G-.

Temperature compensation cannot be applied to this input, because the influence of the temperature measurement on the measured value is not known.

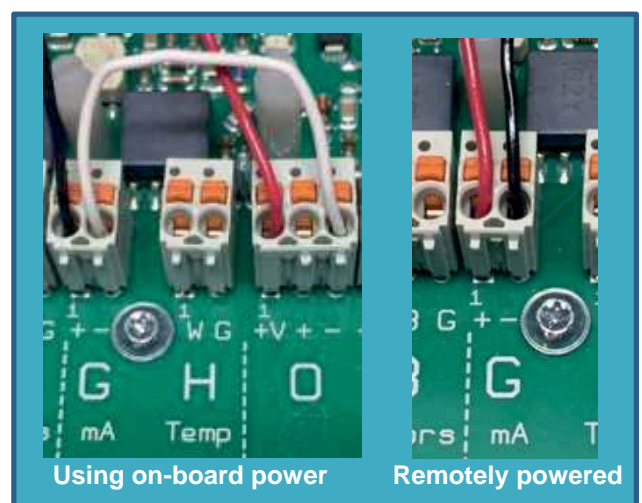

**Figure 32** 'G'; 4-20mA input

## Mounting and Installation

### 6.3.8 Temperature [Input H]

The Aegis II uses a 10mV/°K sensor on analog input H, or a 100Ω or 1000Ω RTD connected to the pH input driver card, if available. Either can be used for temperature display, control or compensation.

A 1KΩ test resistor placed across the H +/- input should net approximately 140°F depending on the resistor tolerance. See Figure 33.



Figure 34 Digital Input wiring

#### 6.3.8.1 Digital Inputs O through V

Inputs O through V are digital inputs. They expect to monitor dry contact signals from contact head and paddlewheel watermeters or any dry contact switch or relay tip. See figure 31. Wire the input between the + and – terminals. See figure 34. Black is on + and white is on -. +V is not used in this example.

Each input has a 16 volt (+V) terminal available as a power source for the sensor or input device. These power sources can also be used to power a 4-20mA loop for the G input. See section 6.3.7.2 The G input (4-20mA).

Digital watermeters that use these terminals must not supply a sine wave or powered signal. If the meter uses a 'hall effect', 'open collector' or 'dry contact' output, you can connect to these inputs.

For additional watermeter information and termination examples, refer to Prominent publication "Industrial Watermeters - Contact Head and Paddlewheel Specification A7". This document can be downloaded from the Prominent.us web site. Enter 'watermeter' in the search box and press enter. Click on the document to download it.

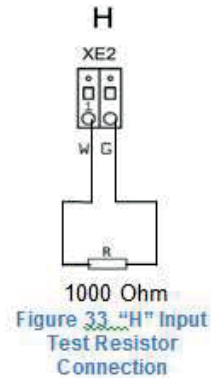

Figure 33 "H" Input Test Resistor Connection

### NOTICE

Various types of watermeter use the V+ terminal. The color and purpose of the wires does not adhere to a standard. Some meters use black for power and red for the signal. Check the watermeter manual.

### 6.3.9 Sensor Driver Cards

The following sections identify wiring diagrams of the sensor driver cards. There are three available expansion slots as shown in section 6.3.5 General Layout and Terminal Diagram.

**NOTE:** The drawings show the location of connections and are meant to be used with the adjoining tables which provide additional information for wiring connections.

There are currently six expansion cards to choose from. Each is described in detail below.

- Dual Serial Input card (CTFs-LPR-DP)
- Dual CT (Conductivity/Temperature)
- Dual pH-ORP-Temp Driver
- ORP/pH Temp mA Input card
- Dual 4-20mA Input Driver
- Dual 4-20mA Output Driver

The three expansion slots are shown in figure 35 and figure 14.

Note the letter designations in yellow. Inputs on these cards will be identified in the program by these letters for clarity.

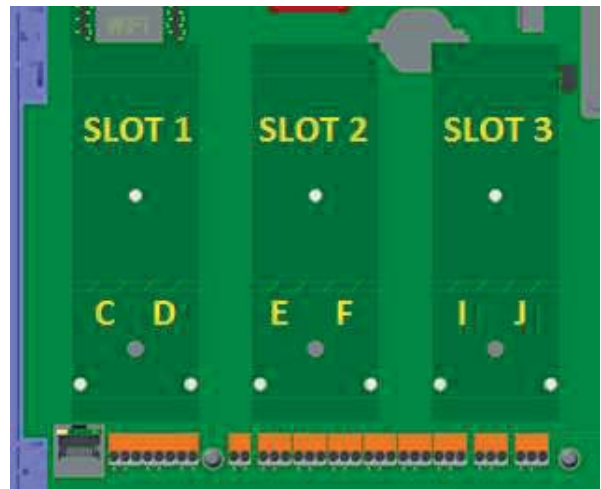

Figure 35 Expansion Card Slots and Letter Designations

### 6.3.10 Dual Serial Input card (CTFs-LPR-DP)

Only certified Prominent serial sensors; CTFS (Conductivity Temperature Flowswitch Serial), Log R corrosion rate sensors and differential pressure sensors may be used with these inputs. Sensor reports analog value in a serial signal.

Maximum distance from sensor to driver card is 30 meters.

Terminals are color coded for ease of connection; R – red, B – black and G – green.



Assignment Variants 734265

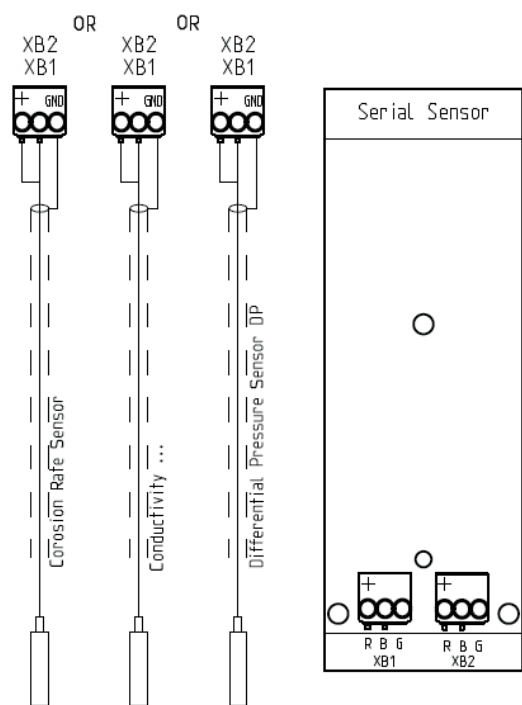

Figure 36 Dual Serial Driver

2 x serial sensor HW Version: 734265 Rev. 2			
Connector	Pins	Description	Color Code
XB1 channel 1	1	5V	RED
	2	Signal UART half-duplex 1	BLACK
	3	GND	GREEN
	4	NC	
XB2 channel 2	1	5V	RED
	2	Signal UART half-duplex 2	BLACK
	3	GND	GREEN
	4	NC	

Table 5 Dual Serial Sensor Connections

Figure 37 Dual Serial Input Driver connections



Figure 38 CTFS sensor (Conductivity/Temperature/Flowswitch/Serial)

# Mounting and Installation

## 6.3.11 Dual CT (Conductivity/Temperature)

The inputs can be any combination of the following ProMinent sensors; 2-wire boiler conductivity, 4-wire cooling conductivity, 4-wire condensate conductivity, LM335<sup>1</sup> (10mV/°K), Pt100 or Pt1000 temperature sensors.

No other conductivity sensors will match the input circuitry.

Temperature can be used for display, control or compensation.

Do not exceed 30 meters, 100 feet, of cable length.

FOOTNOTE 1: LM335 is our SGT sensor, pn 1051507

NOTE: The Prominent Toroidal conductivity sensor emits a 4-20mA signal and therefore requires a 4-20mA input driver.

NOTE: To lengthen a temperature sensor signal, use the temperature transducer and input this signal on a 4-20mA input card.

Assignment Variants 734223

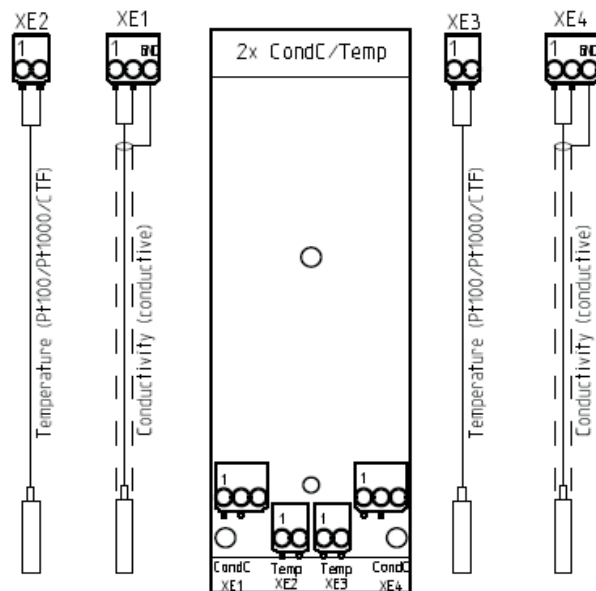

Figure 39 Dual Cond/Temp input Driver Connections



Figure 40 Dual Conductivity Driver

2 x Cond/Temp HW Version: 734223 Rev. 2		
Connector	Pins	Description
Channel 1 XE1	1	Conductivity sensor 1
	2	
	3	shield
XE2	1	(-) Temperature sensor 1 (LM335 White, Pt 100, Pt1000)
	2	(+) Temperature sensor 1 (LM335 Green, Pt 100, Pt1000)
Channel 2 XE3	1	(-) Temperature sensor 2 (LM335 White, Pt 100, Pt1000)
	2	(+) Temperature sensor 2 (LM335 Green, Pt 100, Pt1000)
XE4	1	shield
	2	Conductivity sensor 2
	3	

Table 6 Dual Conductivity Temperature Connections

Typical conductivity card connections



Figure 41 Two Wire Boiler Probe on XE1



Figure 42 Two Wire Boiler Probe

The 2-Wire boiler conductivity probe connects to XE1 or XE4, pins 1 and 2. This sensor is not polarity sensitive.



Figure 43 Four Wire Condensate Probe On XE2



Figure 44 Four Wire Condensate Conductivity Probe

The 4-Wire condensate conductivity probe connects to XE1 and XE2 or XE3 and XE4 as shown. Wires on XE1 and XE4 are not polarity sensitive. The temperature input on XE2 and XE3 must be connected as shown. The green is – and the white is +.

### 6.3.12 Dual pH-ORP-Temp Driver

Two inputs; can both be pH or both be ORP, or one of each.

Any 2-wire pH sensor will work if the mV/pH is ~59.1

Any 2-wire ORP will work if mV is in the range of +/- 1,000mV

The pH, ORP or temperature (Pt100 or Pt1000 only) sensors can be extended a maximum of 10 meters/30 feet from the controller. For longer distances, use a 4-20mA sensor transducer and a 4-20mA input card.

The temperature input sensor can be an LM335<sup>1</sup> (10mV/°K) sensor or either a 100Ω or 1000Ω RTD.

Temperature can be used for display, control or compensation.

If an electrical potential exists in the water, it should be removed. If it cannot be removed, a potential equalization electrode (also called “liquid potential” or “solution ground”) connection can be used.

If a potential equalization electrode is used, the default wire jumper(s) on XE3 and XE7 must be removed before connecting the potential equalization electrode to input XE3:2 and/or XE7:2. If not using a potential equalization electrode, leave the default jumpers in place on XE3 and XE7.

FOOTNOTE 1: LM335 is our SGT sensor, pn 1051507



Figure 45 Dual pH/ ORP Driver

# Mounting and Installation

Assignment Variants: 734131

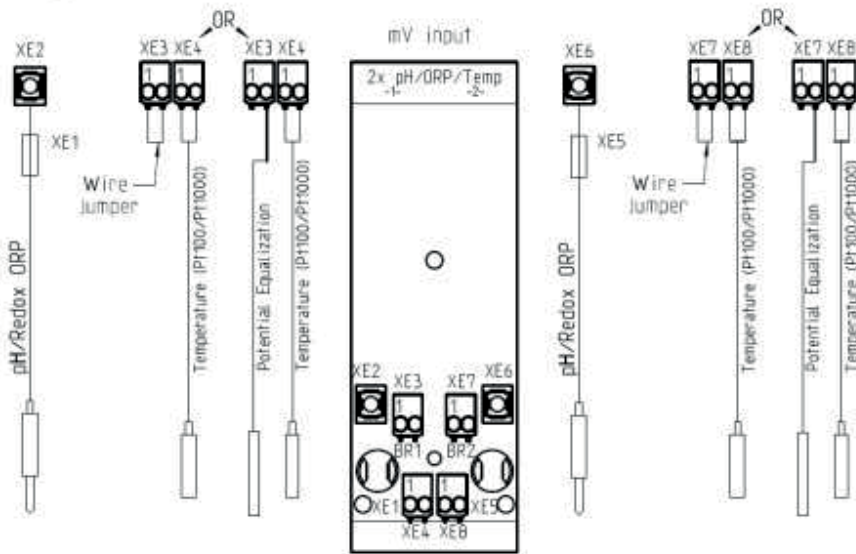

Figure 46 Dual pH/ORP input Driver Connections

Dual pH/ORP with Temp Input HW Version: 734131 Rev.3				
	Connector	Pins	Description	
Channel 1	XE1	-	Reference electrode (Shield)	
	XE2	-	Measurement signal (glass electrode)	
	Without liquid potential	XE3	1	Shor circuit using jumper
		XE3	2	NC
	With liquid potential	XE3	1	Liquid potential
XE4		2	Liquid potential	
Channel 2	XE5	-	Reference electrode (Shield)	
	XE6	-	Measurement signal (glass electrode)	
	Without liquid potential	XE7	1	Shor circuit using jumper
		XE7	2	NC
	With liquid potential	XE7	1	Liquid potential
		XE8	1	(+)Temperature sensor (LM335 White, Pt100 or Pt1000)
	2		(-)Temperature sensor (LM335 Green, Pt100 or Pt1000)	

Table 7 Dual pH-ORP-Temp Connections



### When is potential equalization (Solution Ground) used?

Potential equalization (also called “liquid potential” or “solution ground”) is used if the pH/ORP measurement is interfered with by disturbance potential (millivoltage) from the measurement media. For example, a disturbance potential can be caused by electric motors with incorrect interference suppression or due to insufficient galvanic insulation of electrical conductors etc. Potential equalization does not remove this disturbance voltage, however it does reduce its effect on the measurement. Therefore it is ideal to remove the source of the disturbance potential.



### Ready-made coaxial cable

Whenever possible, only use ready-made coaxial cables that you can select from the ProMinent catalog.

Coaxial cable 0.8 m-SN6 (31.5”), ready-made, order no. 1024105

Coaxial cable 2 m-SN6 (6.5’), ready-made, order no.1024106

Coaxial cable 5 m-SN6 (16.4’), ready-made, order no. 1024107



### NOTICE

#### Jumper and potential equalization (liquid potential or solution ground).

If a “liquid potential” jumper and a potential equalization electrode are both or neither connected, it will cause incorrect sensor readings.

Always leave the jumper connected if not using potential equalization, or remove the jumper when connecting potential equalization.



6.3.12.1 Attaching the pH/ORP coax cable.

Once the cable has been prepared, (Figure 26) attach it to the pH/ORP driver card. Remove the shield grounding nut, XE5, and loosen the center conductor screw, XE6, as shown in Figure 47.

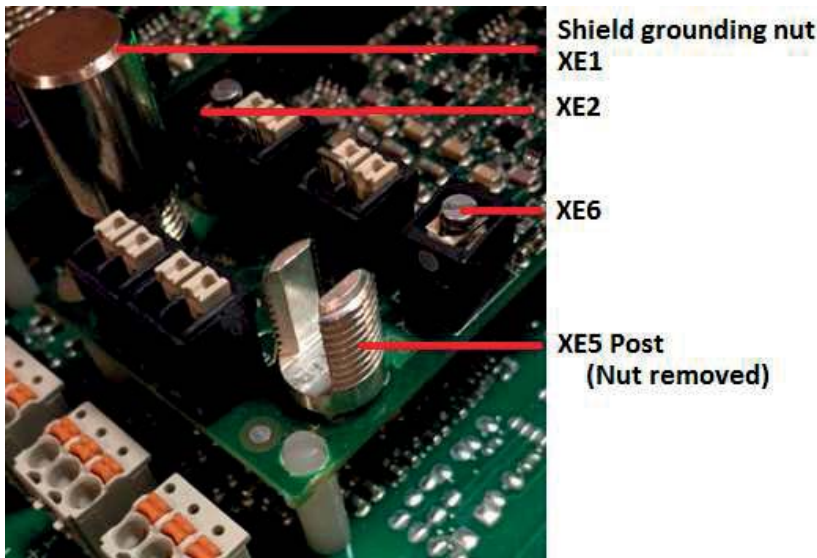

Figure 47 pH/ORP driver card coax connection



Figure 48 Coax placement

Insert the coax center conductor into the XE2 or XE6 terminal and tighten. Place the shield grounding nut on the post, screw down and tighten. This nut is smooth for a reason. Do not over-tighten!

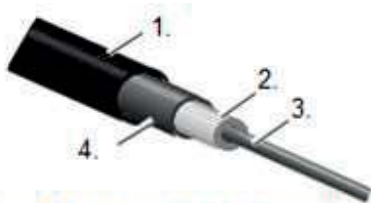

Figure 49 Coaxial Cable Construction

- 1. Protective Outer Sleeve
- 2. Insulation
- 3. Inner Conductor
- 4. Outer Conductor and braided shielding

Outer conductor (4)-10mm  
 Insulation (2)-7mm  
 Inner conductor (3)-7mm



Figure 50 Coax measurement

Coax cables accompany pH and ORP sensors. If you shorten them, be sure to create an end that is a good fit for the card termination.

Remove the black plastic layer from the inner coaxial cable. This is present on all types of cable. In doing so, ensure that individual threads of the bare wire shielding do not come into contact with the inner conductor.

6.3.13 ORP/pH Temp mA Input card

The purpose of the card is to have pH and Free chlorine on one driver card.

Any 2-wire pH sensor will work if the mV/pH is 59.1

Any 2-wire ORP will work if mV is in the range of +/- 1,500mV

The pH, ORP or temperature (Pt100 or Pt1000 only) sensors can be extended a maximum of 10 meters/ 30 feet from the controller. For longer distances, use a 4-20mA sensor transducer and a 4-20mA input card.

The temperature input sensor can be an LM335<sup>1</sup> (10mV/°K) sensor or either a 100Ω or 1000Ω RTD.

Temperature can be used for display, control or compensation.

The 4-20mA input can be connected to an active or passive loop. This input is isolated from the motherboard.

Any 4-20mA input is acceptable; however, there is no square root operation for older flow meters as found in some boiler rooms. (We have never provided this service.)

Enter any engineering units for the range. 4mA does not have to be 0.

# Mounting and Installation

Maximum load per loop is 50mA. Short circuit protection at 70mA. Reactivation after 10 seconds. We recommend a maximum length of 1,000 feet using 22 AWG wire or larger. Twisted, shielded, stranded cable is best for long distances.

If a potential equalization electrode is used, the default wire jumper on XE3 must be removed before connecting the potential equalization electrode to input XE3:2. If not using a potential equalization electrode, leave the default jumper in place.

**FOOTNOTE 1: LM335 is our SGT sensor, pn 1051507**

Assignment Variants 734355

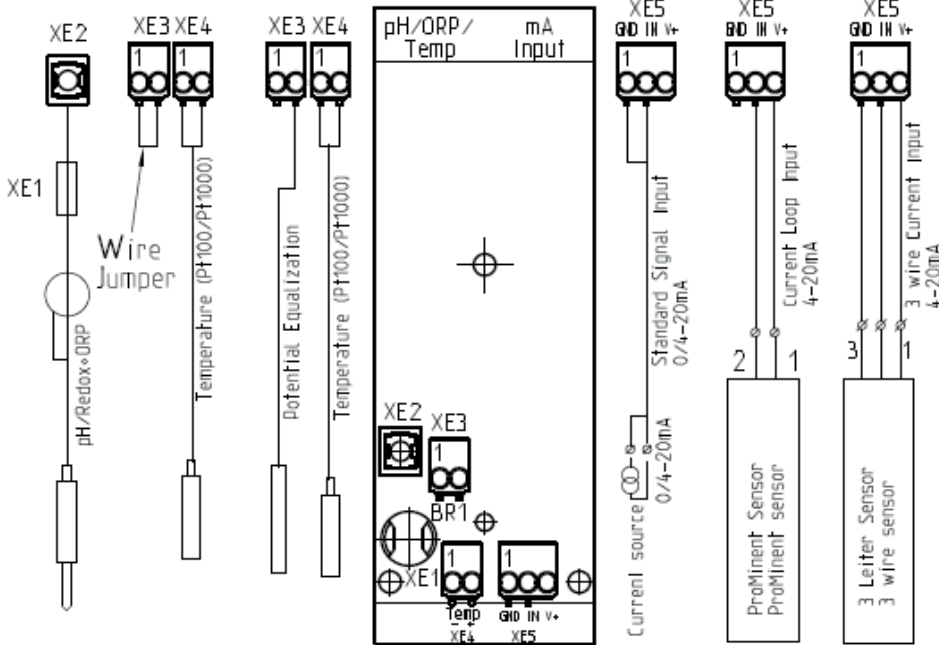

Figure 51 pH/ORP=Temp- 4-20mA Input Driver connections



Figure 52 Prominent Industrial ORP and pH sensors

pH/ORP-Temp-4-20mA Input HW Version: 734355 Rev.				
Connector	Pins	Description		
Channel 1	XE1	-	Reference electrode (Shield)	
	XE2	-	Measurement signal (glass electrode)	
	XE3 Without liquid potential	1	Shor circuit using jumper	
		2		
	XE3 With liquid potential	1	NC	
		2	Liquid potential	
XE4	1	(+)Temperature sensor (LM335 White, Pt100 or Pt1000)		
	2	(-)Temperature sensor (LM335 Green, Pt100 or Pt1000)		

Table 8 pH/ORP – Temperature Connections (Continued next page)

Connector	Pins	Active 2 wire mA input	Active 3 wire mA input	Passive mA input
XE5 channel 2	1	(-) NC	(-) GND	(-) GND
	2	(+) mA input	(+) mA input	(+) mA input
	3	(V+) 23V	(V+) 23V	(V+) NC

Table 9 pH/ORP-Temp- 4-20mA Input Sensor Connections

## 6.3.14 Dual 4-20mA Input Driver

The dual 4-20mA input card can handle active and passive loops. Both inputs are isolated from each other and the motherboard.

Any 4-20mA input is acceptable; however, there is no square root operation for older flow meters as found in some boiler rooms. (We have never provided this service.)

Enter any engineering units for the range. 4mA does not have to be 0.

Maximum load per loop is 50mA. Short circuit proof at 70mA. Reactivation after 10 seconds. ProMinent recommends a maximum length of 1,000 feet using 22 AWG wire or larger. Twisted, shielded, stranded cable is best for long distances.

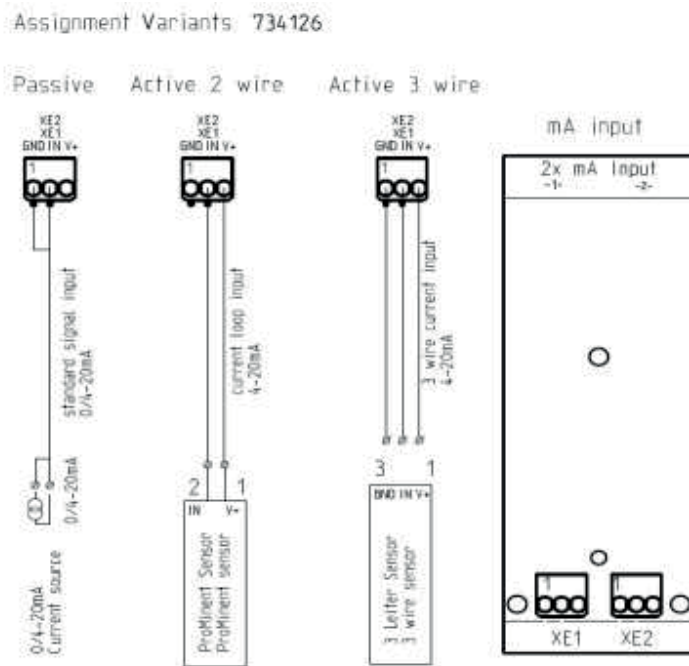

Figure 53 Dual mA Input Driver Connections



Figure 54 Dual 4-20mA Input driver

2 x mA inputs				
HW Version: 734126 Rev. 4				
Connector	Pins	Active 2 wire mA input	Active 3 wire mA input	Passive mA input
XE1 channel 1	1	(-) NC	(-) GND	(-) GND
	2	(+) mA input	(+) mA input	(+) mA input
	3	(V+) 23V	(V+) 23V	(V+) NC
XE2 channel 2	1	(-) NC	(-) GND	(-) GND
	2	(+) mA input	(+) mA input	(+) mA input
	3	(V+) 23V	(V+) 23V	(V+) NC

Table 10 Dual mA Input Connections

## 6.3.15 Connection of Amperometric Sensors

ProMinent amperometric sensors can be terminated to a 4-20mA input driver card.

Connect the sensor, as described in section [6.3.14 Dual 4-20mA Input Driver](#)

**Note:** if connecting a non-powered sensor to G input you will need to use 15VDC power supply from either one of the digital inputs or an external power supply. If power is pulled from a digital input, the digital inputs will no longer be isolated from 4-20mA input G, since they are sharing the same power supply. For this reason, we will not use the G input for ProMinent amperometric sensors. A toroidal conductivity probe or EcoPod level sensor will work.

## Mounting and Installation

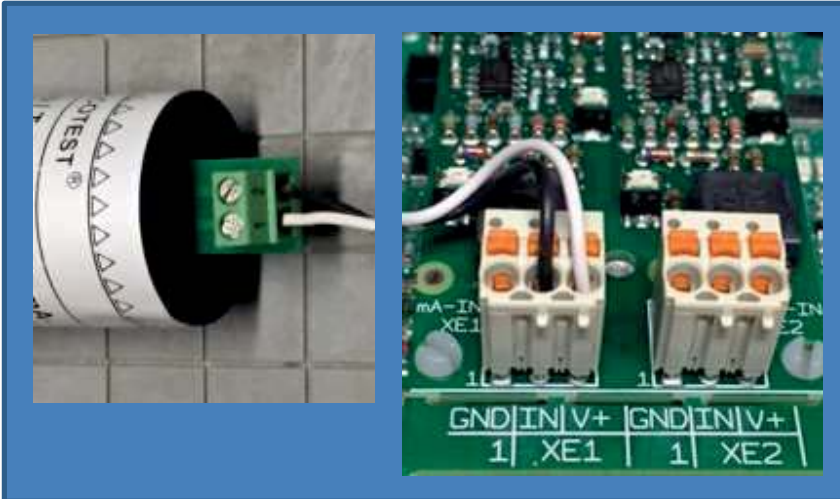

Figure 55 Amperometric probe to 4-20mA Input Driver

Pin 1 on the Prominent amperometric sensor is connected to the V+ terminal

Pin 2 on the sensor is connected to the 'IN' terminal

Shown connected to XE1

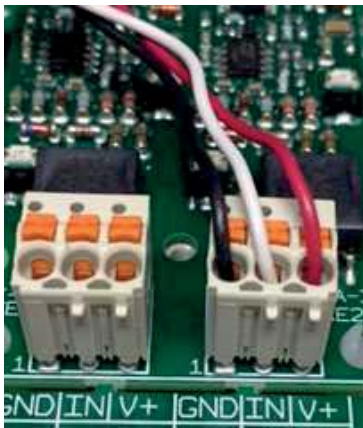

Figure 56 Three wire 4-20mA inputs that utilize V+

MilliAmp inputs from powered devices do not need on-board V+. The + wire from the Input device, (analyzer, PLC, etc), connects to the 'IN' terminal and the – wire to the 'GND'.



Figure 57 Two wire remotely powered Analog input

### NOTICE

Analyzers and computer systems, DCS, PLC etc, typically have 120VAC. Therefore signals from these devices can be powered from them. However, the signals often have the option to allow the current loop to be powered from the receiving end. In this case, the receiving end is this controller.

The purpose of this page is to show how to wire inputs from devices that need to be powered from the controller, figures 55 and 56, and inputs that are powered remotely, figure 57.

6.3.16 Dual 4-20mA Output Driver

Two outputs fully isolated from each other and from the mother board.

Output open loop alarm; Maximum load of 450ohm @ 21.5mA, 480 ohm @20.5mA. Drive voltage maximum; 18VDC open circuit. We recommend a maximum length of 1,000 feet using 22 AWG wire or larger. Twisted, shielded, stranded cable is best for long distances.

Does not have a passive output. The loop is powered by the driver card.  
Scale to any engineering units, forward or backward.

Examples:

4mA = 200 GPM and 20mA = 0 GPM

4mA = 32°F and 20mA = 212°F

4mA = -500mV and 20mA = 500mV

Can be used for proportional control of a pump or analog valve.

Can be used as a process variable to a DCS or chart recorder.



Figure 58 Dual 4-20mA Output driver

Assignment Variants 734143

2 x mA Outputs HW Version 734143		
Connector	Pins	2 wire mA output
XA1 Channel 1	1	(-) mA output -
	2	(+) mA output +
XA2 Channel 2	1	(-) mA output -
	2	(+) mA output +

Table 11 Dual mA Output Connections

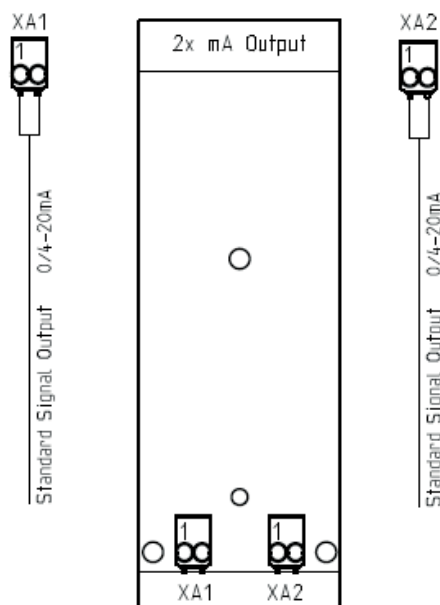

Figure 59 Dual mA Output Connections

The dual 4-20mA output driver is equipped with onboard power which is used to power or excite, the output loops. Therefore, the input device must not power the loop. mA loops cannot be powered from two sources!



Figure 60 Dual mA Output with Prominent Universal Control Cable on output 1.

## 7 Communication

### 7.1 Diagram of the Communication Modules

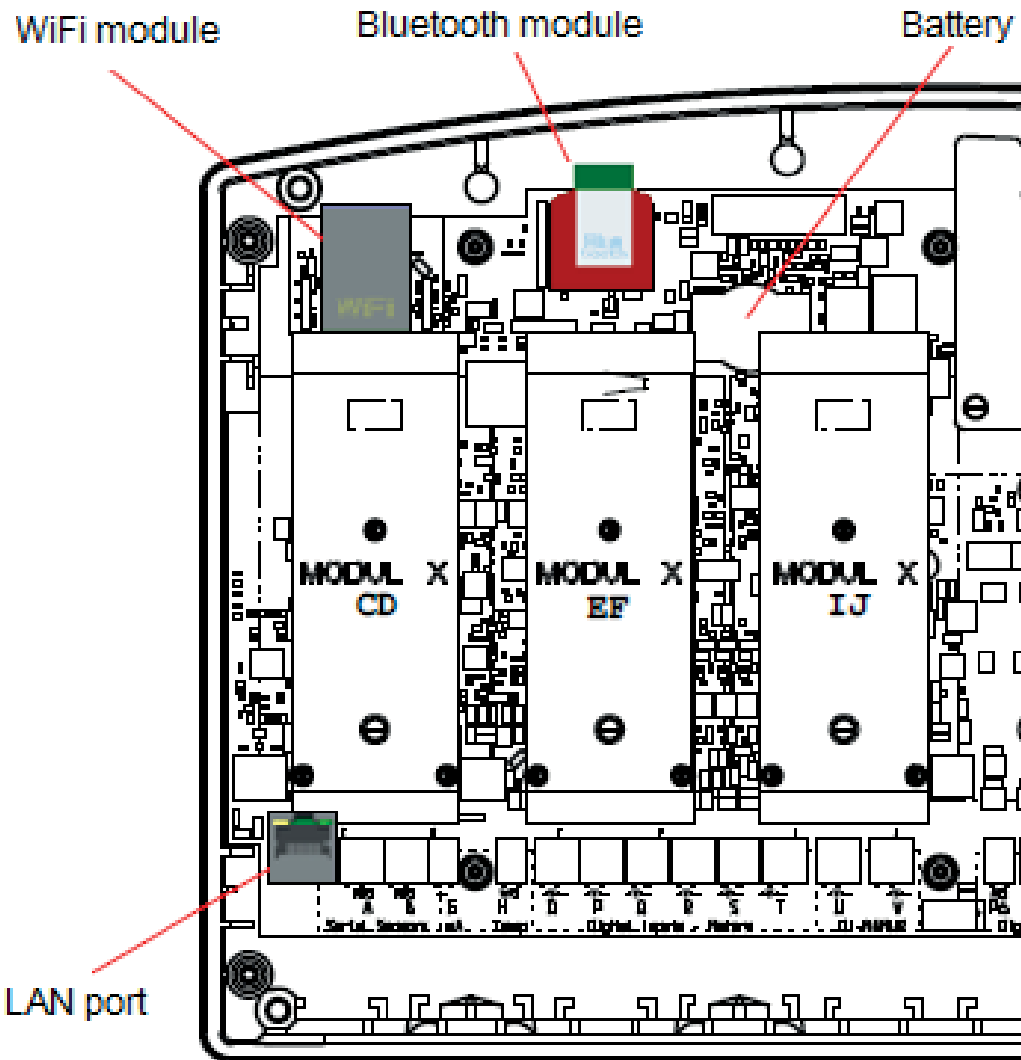

Figure 61 Illustration of the various communication ports and modules

## 8 Commissioning

User qualification: trained user, see ↩ Chapter 4.4 'Users' qualifications'.

After mechanical and electrical installation, turn on the sample stream, check for leaks and purge any trapped air.

### 8.1 Switch-on behavior during commissioning

```
Aegis II Power up...
Contact set states:
ON = + OFF = ≠
```

Switching On - First Steps

Power up sequence will first show the 4 line x 20 character LED display for 3 seconds:

```
2300uS      7.92pH ↕
345mV      78F
5493.2G    ↕26.5 min
STATUS ALARMS SETPNT
```

Followed by the "Home" screen of up to 6 sensor readings with the bottom line reserved for labels above the 3 dynamic keys F1, F2 and F3:



### CAUTION!

#### Installation and function control

Check that all the electrical connections have been made correctly

Ensure that the supply voltage matches the voltage range indicated on the data plate

### 8.2 Defining Metering and Control Processes

Define the following parameters to set up a controller:

- What type of a process control is planned?
- Which measured variables are there?
- Is there an in-line, batch or circulation process planned?
- Should the controls operate as ON/OFF, proportional or PID control?
- Which control variables are there?
- What control parameters are necessary?
- How should the feeders and actuators be controlled?
- How should any mA inputs or outputs be configured?
- Are there chemicals to be fed using timed feed or a fluorescent marker/dye?

## 9 Programming the Inputs

This section will depict the keystrokes necessary to edit the program, calibrate sensors or find information.

### NOTICE

For a faster and easier initial configuration, ProMinent recommends that general configuration of the controller, especially during commissioning, be performed using a portable computing device like a laptop or a tablet computer. Refer to the Aegis II Browser manual for more information.

The keypad interface instructions in this manual are intended to show an operator how these individual tasks can be performed from the keypad.

## Programming the Inputs

Factory programming of sensor inputs is based on your specific order. This may include controlling relays for pumps and solenoids. Some inputs require further setup. The factory does not setup analog flow or level inputs. However, this can easily be accomplished in the field if the range of the analog input is known. Refer to the calibration chapter

### 9.1 Analog and Digital Inputs

#### 9.1.1 Enable an Analog or Digital Input:

This includes all analog and digital inputs other than the CTFS sensor. See section 9.1.2 Enable a CTFS Sensor.



### Available Sensors

Sensor availability in the menus is dependent upon the installed driver cards. All sensors possible for each of the driver cards are made available at bootup. Sensor will probably need to be enabled after the driver card and sensor(s) are installed, and the controller is rebooted.

- 1- Press the MENU key.
- 2- Use the Up and Down ARROW keys to find and point to the **System** choice and press the **OK** button once.
- 3- The display will change to the System menu. Scroll up or down through the choices until the arrow points to **Enable I/O** then press **OK**
- 4- Using the arrow keys, scroll through the disabled I/Os until the you see the input you wish to enable
- 5- Press ENABLE [F3] key.
- 6- The input has been enabled and the display returns to the System menu to enable additional sensors if desired.
- 7- Press ESC (Escape) to exit

**Note:** If you enable a Serial Conductivity sensor (CTFS), the temperature and flowswitch need to have input letters assigned to them **at that time**. This is done at the factory when CTFS sensors are ordered with the controller. If you add a second CTFS in the field, use the 'Enable CTFS Sensor' instructions below.



## WARNING!

### Sensor run-in period

This can result in hazardous incorrect metering

Take into consideration the sensor's run-in period during commissioning:

There has to be adequate feed chemical in the sample water for your application (e.g. 0.5 ppm chlorine)

Accurate measuring and metering is only possible if the sensor is working correctly.

It is imperative that you adhere to the sensor's run-in periods before calibration and control.

Calculate the run in period when planning commissioning. It may take a whole day to run in some sensors.

Refer to the sensor's operating instructions.

```
2300uS    7.92pH #
345mU     1.5PPM
5493.2G   2.49GPM
STATUS ALARMS SETPNT
```



```
MENU
I/O Status #
▶ System
Home
```



```
System #
Time&Date
Set Sensor Type
▶ Enable I/O
```



```
Enable I/O #
9:P9 unused
▶ C:pH          ENABLE
```



```
System #
▶ Enable I/O
Password
Activity Log
```





## 9.1.2 Enable a CTFS [Conductivity, Temp, Flow, Serial] Sensor

- 1- Press the **MENU** key.
- 2- Use the Up and Down ARROW keys to find and point to the **System** choice and press OK.
- 3- Scroll down to **Enable I/O** and press **OK**
- 4- Scroll down to the **CTFS** sensor you wish to enable and press **F3** (Enable) Note the letter assigned to this sensor! It will be used in steps 7 and 9 below.
- 5- From the **Enable I/O line**, press **OK**
- 6- Scroll down to an unused analog input (A through N) and press **F3** to ENABLE it.
- 7- Scroll up until you see the temperature assignment for the new CTFS. (A1 in this example. It will have the first letter from step 4 above.) Press **F3**.
- 8- From the **Enable I/O line**, scroll down until you find an unused digital input, (O through Z) and press **F3**, ENABLE.
- 9- Scroll up until you find the Contact Set assigned to the sensor in step 4 above. A2 in this example. Press **F3** to SELECT.
- 10- Press **ESC** (Escape) to go back

## 9.2 Naming an Input or Output

## 9.3 Changing a Descriptor

Once you have enabled an input or output, naming is helpful in avoiding programming mistakes. Choose a name that describes the sensor so that when multiple sensors of the same type are on the same controller or process, it is easy to tell them apart. An abbreviation of the application is recommended.

(e.g. pH Tower 2)

This procedure is the same for all I/O points; Inputs and Outputs, digital and analog and includes 4-20mA points. When you name an input, you are changing the “descriptor”. This is how it is done:

- 1- Press **MENU**.
- 2- Scroll down to **I/O Setup**. Press **OK**.
- 3- Scroll down to the relay you chose to name and press **OK**. If your relay is not listed, it is not enabled. See **10.2, Determine if a Relay is Enabled**.
- 4- Press **OK** to edit the “descriptor” of the relay.
- 5- Notice the **F2** key represents the word ‘alpha’. You have three choices, ALPHA

(upper case letters), alpha, (lower case letters), and NUMBERS, 0 through 9. Since the lower case

‘alpha’ is seen, please realize that this is a choice, not the current selection.

- 6- The default choice is upper case so use the up and down arrows to change the R in Relay to B for Blowdown or A for acid, etc.
- 7- Use the right arrow to move to the second

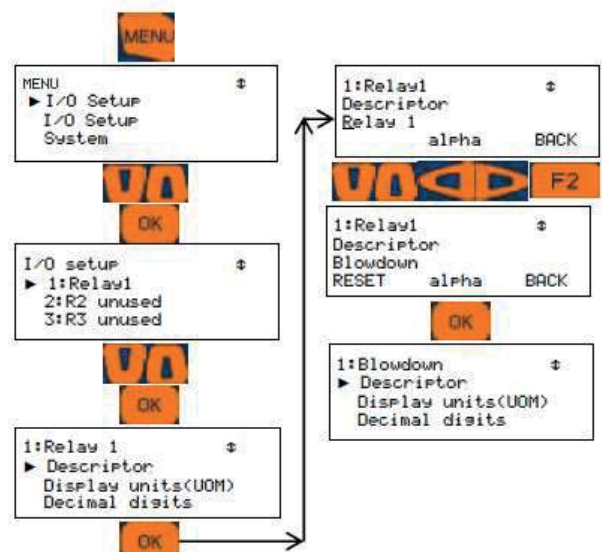
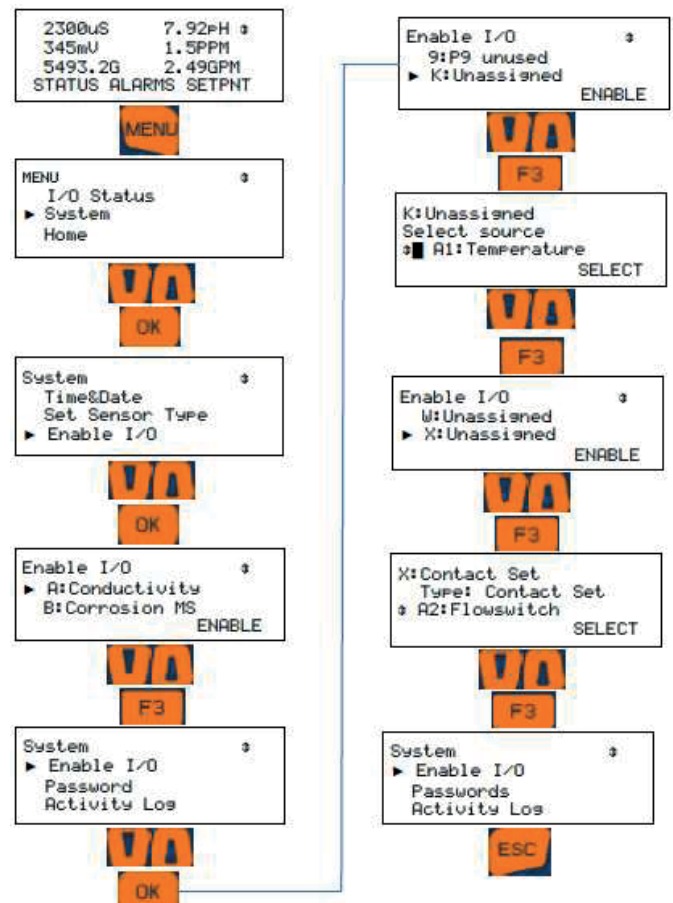

## Programming the Inputs

position. Press the **F2** key to choose **alpha**, lower case letters. Notice that the F2 choice now shows NUMBERS. That would be the next choice.

- 8- Use the arrows to change the 'e' to 'l' and continue until your word is spelled.
- 9- When finished, press **OK** to save.

- 7 Use the up/down arrows to change the range as needed. Press **F2** SELECT to save. Press **ESC**

### 9.4 Selecting an Analog Sensor Type

ProMinent amperometric sensors are compatible with the Aegis II via the isolated 4-20mA Input driver. Once the sensor type is selected, the controller will scale the input, provide calibration limits for the type selected, and clamp the measured sensor values so that an open loop does not measure a negative value.

Sensor Type	Span Options & units	mA Span	G=Gain, O=Offset Span not user modifiable
Unassigned	Generic 0-100	4-20	User modifiable span G= 6.25, O=-25
CBR Bromine	CBR 0-2ppm	4-16	G=0.167, O=-0.667
	CBR 0-10ppm	4-16	G=0.833, O=-3.333
CGE Chlorine	CGE 0-2 ppm	4-16	G=0.167, O=-0.667
	CGE 0-10ppm	4-16	G=0.833, O=-3.333
CLE3 Chlorine	CGE 0-2ppm	4-16	G=0.167, O=-0.667
	CGE 0-10ppm	4-16	G=0.833, O=-3.333
CLO Chlorine	CLO 0-2ppm	4-16	G=0.167, O=-0.667
	CLO 0-10ppm	4-16	G=0.833, O=-3.333
CTE Chlorine	CTE 0-2ppm	4-16	G=0.167, O=-0.667
	CTE 0-10ppm	4-16	G=0.833, O=-3.333
Diff.Pressure	DeltaP 0-100psi	4-20	G= 6.25, O=-25
Fluorescent	Fluor 0-200ppm	4-20	G= 12.5, O=-50
PAA 0-200ppm	PAA 0-200ppm	4-16	G=16.67, O=-66.67
	PAA 0-2000ppm	4-16	G=166.67, O=-666.67
pH-transducer	pH 0 to 14	4-20	4mA=-15.45pH 20mA=-1.45pH pH outside of 0-14 blocked G=-1.056, O=19.675 5.373mA=14pH, 18.6mA=0pH
ORP-transducer	ORP 0-1000mV	4-20	G= 62.5, O=-250
Temperature	Temp. 0-100C	4-20	G= 6.25, O=-25
Toroidal	Tor. 0-10000uS	4-20	G= 625, O=-2500
	Tor. 0-100000uS	4-20	G= 6250, O=-25000

Table 12 4-20 mA Sensor

If your 4-20mA device is not on this list above, choose 'other' and enter the scale manually. See procedure following the pre-configured 4-20mA chart

#### 9.4.1 Selecting the sensor type:

- 1 Press **MENU**
- 2 Scroll up to **System**. Press **OK**
- 3 Scroll down to **Set Sensor Type**. Press **OK**
- 4 Scroll down to the 4-20mA input where the sensor is connected. Press **F3** SELECT
- 5 Scroll down until you see the type of sensor you have and press **OK**
- 6 Press **F1** to select the probe range.



### ORP sensors measure more than just chlorine.

The only acceptable calibration is to a calibrated mV source, not an oxidant residual. ProMinent recommends testing the probe for movement and adjusting the set-points if necessary, to reach the desired oxidation control range.

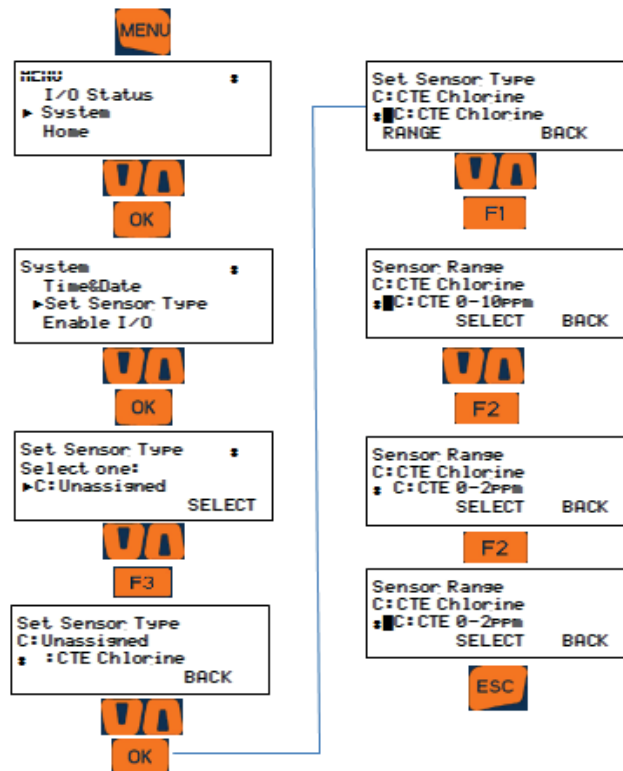

### 9.5 Analog Sensor Cleaning and Calibration

#### 9.5.1 General remarks

Combination probes for the measurement of pH and redox-ORP potential consist of a measuring electrode – a glass electrode for pH, a platinum or gold electrode for redox measurement and a reference electrode, arranged concentrically around the measuring electrode.

**9.5.2 Sensor Commissioning**

Before putting into operation, the protective cap or case must be removed from the glass or metal electrode. The glass or metal electrode must be free from oil, grease and other contaminations. Likewise, the diaphragm of the reference electrode must be free from scale deposits, dirt or crystallized matter. For these reasons, electrodes should never be touched by hand. If contaminations are present refer to Chap. 4. "Cleaning and servicing".

**9.5.3 Calibrating and checking probes**

**9.5.3.1 Calibrating pH probes**

Zero calibration: since pH probes are subject to certain manufacturing tolerances, they must be tuned to the pertinent pH transmitter. The adjustment intervals depend on relevant operating conditions. They can vary from a few days to up to 8 weeks.

Having connected the probe to the transmitter by means of the probe cable (taking care that connectors and cable remain absolutely dry), dip the probe into a pH 7 standardizing solution and adjust transmitter exactly to read this value.

Remove the probe, rinse it with water, preferably distilled water, and dry it by swabbing it with soft, lint free tissue paper.

Immerse the probe in a buffer solution differing by a least 2 pH from pH 7 and calibrate after the value on the display has stabilized. If within 30 seconds a steady-state value is not produced or calibration has proved impossible, clean probe as described in Section 4 and repeat calibration. If again unsuccessful, replace probe with a new one.

**9.5.3.2 Checking redox/ORP probes**

With the probe connected to the controller by means of the probe cable (taking care that connectors and cable remain absolutely dry), dip the probe into a redox-ORP standard solution, e.g. of 465 mV.

The reading should reach or exceed this value within not more than 30 seconds. If the reading rises rather sluggishly or falls short more than 20 mV, clean the probe as described in Section 4 and repeat check. If again unsuccessful, replace the probe with a new one, or adjust the ORP set-point accordingly.

**NOTE** A calibration of the transmitter or ORP input driver card will not normally be required. This procedure serves as a probe check only.

**9.5.4 Cleaning and servicing probes**

All pH and ORP probes should regularly (once a month) undergo a visual check and be cleaned if necessary.



**CAUTION!**

**Do not rub**

This might cause damaging static electricity and false readings.

If deposits on the glass electrode withstand cleaning with a soft, moistened cloth, or a soft toothbrush the following cleaning agents may be used:

Kind of deposit	Agent and duration of application
General deposits	Non-abrasive household cleaner like Dawn® or 409®
Scale or metal hydroxides	Diluted hydrochloric acid (approx. 0.1-3 %, 1-5 minutes)
Oil, grease	Solvents, like alcohol
Biofouling	Mixture of diluted hydrochloric acid and pepsin, several hours. Solvents (e.g. acetone) must not be used to clean electrodes as they can damage the plastic

**Table 13 Glass electrode cleaning agents**

It is essential that the probes are rinsed thoroughly after cleaning or using a buffer solution.

If the laterally arranged ceramic diaphragm of the reference electrode is blocked, it may be cleaned like the glass electrode. In addition it may be cleaned by cautious scraping with a finger nail, a razor blade or a fine file, but care must be taken that the diaphragm is not scratched.

---

## Programming the Inputs

---

### 9.5.4.1 Storage

The pH and redox-ORP combination probes may only be stored wet. For this purpose, pour a little 3-molar KCl solution into the protective cap or case and slide or screw on to the sensor.

Ensure by a visual check that the pH probes are free from entrapped air bubbles. If air bubbles are present, remove them by vigorously shaking the probe downward (like an old-school mercury fever thermometer).

Probes with KCl filling solution or gel should only be installed in open-ended in-line probe housings (max. 0.5 bar), type DLG III, or immersion-type probe housings, type ETS. Pressurized systems require special probes with a plastic electrolyte.

### 9.5.4.2 Service life

Probes are subject to natural ageing even if handled correctly. Depending on the application, a service life of between 6 months and maximum of several years may be expected.

In individual cases, particularly when extreme service conditions are involved, their lifetime may be reduced to a matter of days.

\*Subject to technical alterations.

### 9.5.5 Calibration Notes

Temperature Compensation: Conductivity sensors should always be temperature compensated, with the exception of the boiler conductivity probes. In the Aegis II the conductivity temperature compensation can use either an internally integrated temperature sensor or a temperature sensor external to the conductivity sensor. **Note:** If the temperature reading is off by more than 3°F, you may have a failed probe or wiring problem. After any temperature calibration, test the temperature sensor with an ice bath.

If the calibration was not successful (more than +/- 50mV offset) it will display "Sensor fault Overrange".



#### CAUTION!

pH and redox-ORP electrodes have a limited shelf life, which is why we do not recommend storing them for more than three months.

Do not use distilled water for soaking, since this will lead to premature ageing and damage to the reference system.



**CAUTION!**

Correct sensor operation / Run-in period

Accurate measuring and metering is only possible if the sensor is working correctly.

Please read the operating manual for the sensor for more information.

Please also read the operating manuals for the fittings and other components used.

It is imperative that the run in periods of the sensors are adhered to.

The run in periods should be allowed for when planning commissioning.

It may take an entire 24 Hour day to run in a new CTE or CGE sensor.



**Calibrations with pH Compensation**

It is important that you always calibrate the pH sensor before any pH compensated sensor, like free chlorine. Otherwise the chlorine calibration and measurement will be incorrect.

OR

3b- (2-Point Calibration) Place the sensor into a known value sample or pH buffer (i.e. 7.00 pH buffer). Adjust the reading until it is equal to the wet test or buffer. Press **F1** to continue to the NEXT buffer.

**9.6 General Sensor Calibration**

All analog sensors can be calibrated directly based on a wet test, or using a 2-point method. You can reset the input to factory default calibration as well.

- 1- Press the **CAL** button.
- 2- Use the Up and Down arrows to locate the sensor you wish to calibrate and press **OK**.

Notice the underline in the current value on the next screen. That is the cursor. In this single point calibration screen, the up and down arrows will adjust this digit. The right and left arrows will move the cursor to a different decimal digit to match your wet test. Pressing **F1** SAVE completes the single point calibration adjustment, -or- Pressing **F3** MORE gives you more calibration options.

The calibration program allows you to select a single or 2-point calibration method. Once chosen, the screen that follows step 2 above will be that choice. From this screen, you can select **F3**, MORE, to switch back to the other mode or select reset to factory calibration.

3a- (Single Point Calibration) Edit the value and press **F1** to SAVE. Choose **F1** again to calibrate another sensor or press **ESC** to exit.

- 4- Place the sensor in the second buffer (10.00 pH) or known sample and edit as before. Press **F1** to SAVE and finish or **F3** or **ESC** to CANCEL.

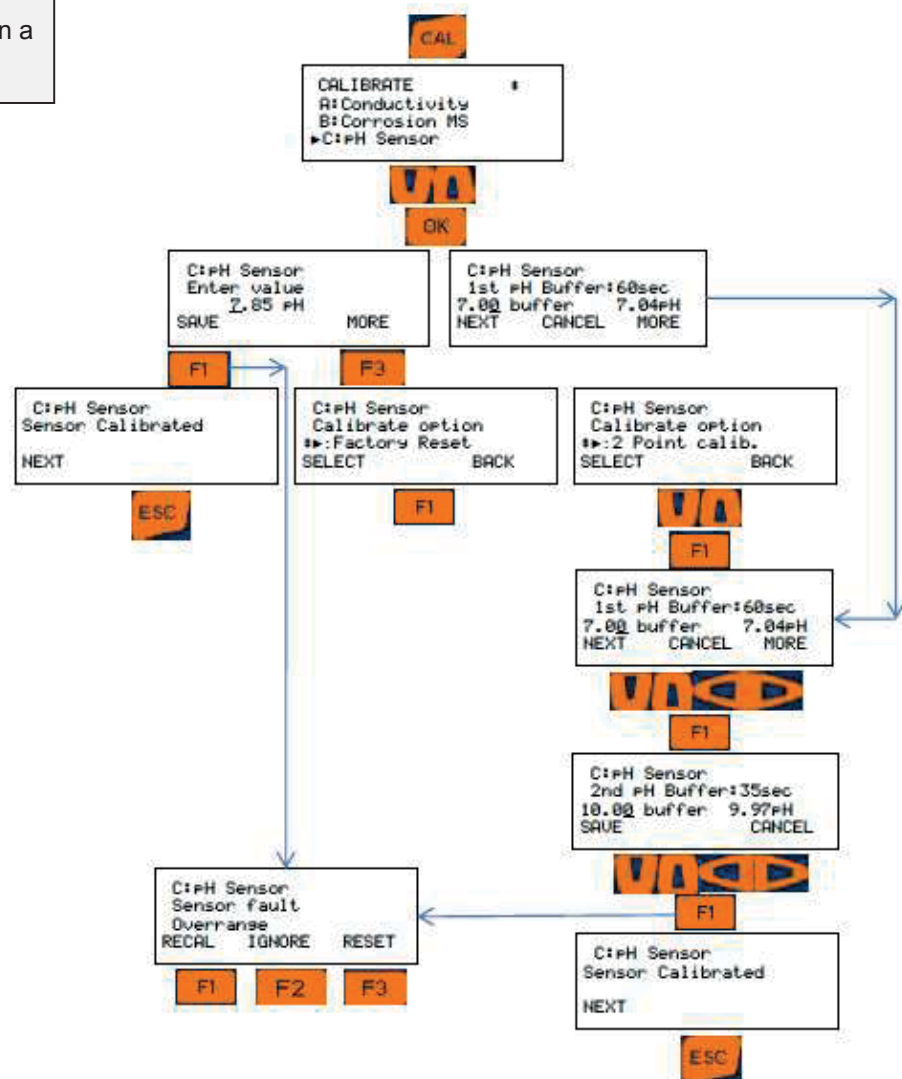

## Programming the Inputs

The controller may accept the value and show the Sensor Calibrated screen.

If the value entered is too far from what the controller has calculated as valid, based on the input signal, a fault message will be displayed. Then you will be given 3 choices on how to proceed.

Press **F1** to RE\_CAL-ibrate the sensor [try again, maybe you forgot to put the sensor in the buffer?...].

Press **F2** to IGNORE the fault and keep the current calibration even though it is not generally advisable. The controller will perform the math to make the display match your entry. The ability to track changes may be marginal or not possible if the sensor is faulty.

Press **F3**, RESET to cancel this calibration and return to the previously saved calibration.

### 9.7 Calibrating an Amperometric Sensor

- 1- Press the **CAL** key
- 2- Scroll down to the sensor you wish to calibrate. Press **OK**
- 3- Get a sample and run a DPD test. Use the timer on the screen. Press **F1** DPD to start the clock.
- 4- When the timer reaches the limit for your test, read the test value and enter it here using the arrows. Press **F1** to SAVE the change.
- 5- Use the **MORE** button to reset the input to factory default.
- 6- The controller should accept the value and show the Sensor Calibrated screen.
- 7- If the value you enter is too far from what the controller has calculated as valid based on the input signal, a sensor fault message will be displayed.

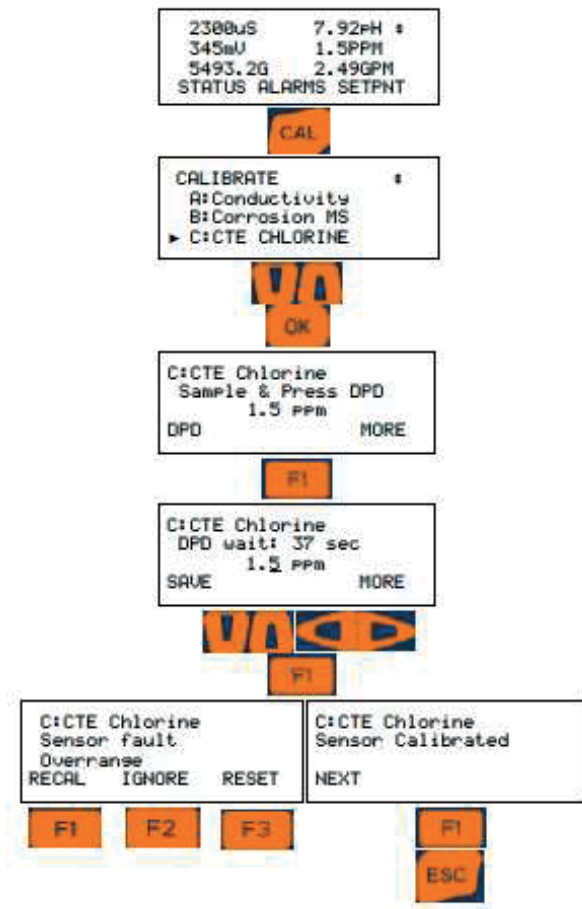

If there is a Sensor fault:

Press either **F1**, RE-CAL to repeat the sensor calibration.

Or press **F2** to ignore the fault and keep the current calibration even though it is not generally advisable. The controller will perform the math to make the display match your entry. The ability to track chemistry changes may be marginal or not possible if the sensor is faulty.

Or press **F3**, RESET to cancel this calibration and return to the previous calibration.

### 9.8 Analog Sensor Alarms

Analog inputs have high and low alarms, to alert the operator if a measured value is out of the normal operating range. All alarms in the Aegis II are latching alarms. Latching alarms do not reset themselves if the parameter recovers back into the acceptable range. The operator must acknowledge the alarm for the alarm light and relay to reset to the OFF mode.

Latching alarms are especially helpful for remote installations where the operator checks on the system a few times a day or less. Under certain circumstances, if there is a control or feed problem and the alarm does not latch, the operator would not know there is an issue.

The Aegis II also has an option to delay the alarm before alerting the operator. This feature is most helpful in applications where trapped air or other conditions cause the sensor reading to spike occasionally, but it is normal operation for that process.

Without the delay the controller would have frequent nuisance alarms that would require acknowledgement by the operator. This option is in minutes and adjustable from the alarms menu. See below.

Alarm

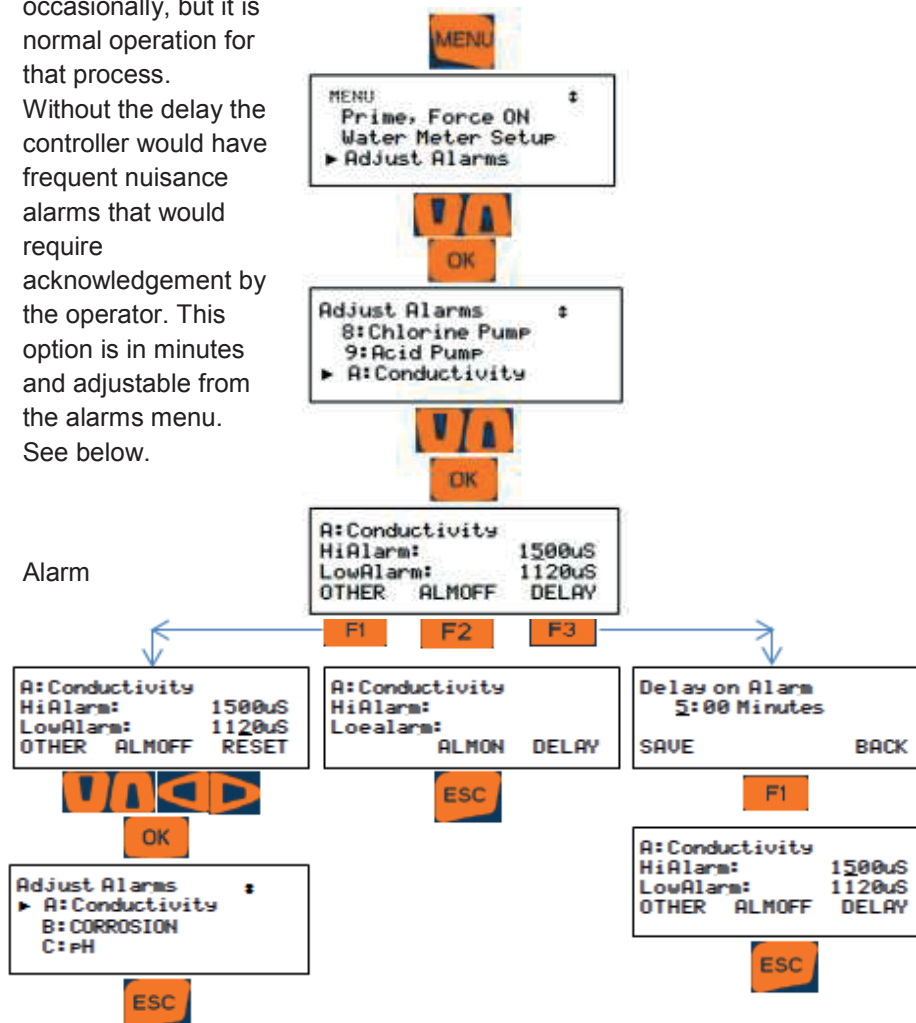

settings for all Inputs and outputs work in the same way. There are 3 types of settings for the alarms on any I/O.

- Adjust Alarms changes the High and Low alarm limits.
- Delay on Alarm adjusts the time the Aegis II will wait before activating and latching an alarm,
- Clear Alarms, as implied will clear all alarms. Follow the steps below to alter the Alarm limit settings for any alarm.

#### 9.8.1 Analog Alarm Configuration

- 1- Press **MENU**
- 2- Scroll down to **Adjust Alarms** and press **OK**
- 3- Scroll down until you locate your sensor and press **OK**

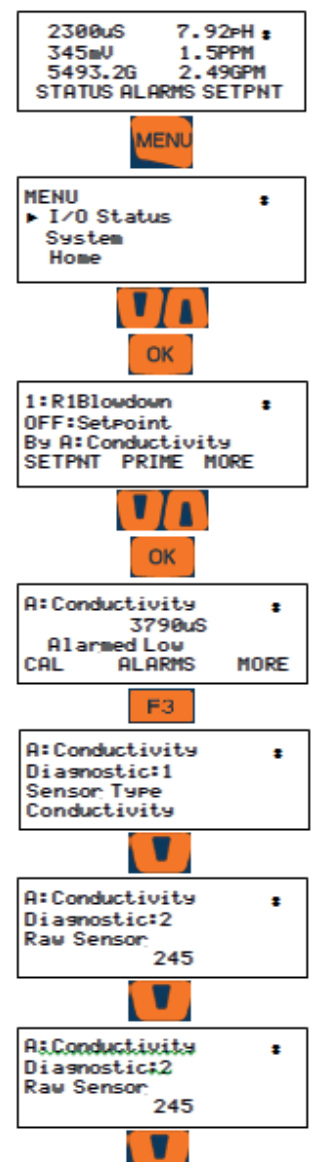

---

## Programming the Inputs

---

Note the underline in the high alarm value. This is the cursor.

Driver cards have a list of other items that are used for factory tracking and troubleshooting.

You now have 3 choices; Edit the High and Low values, (**F1** OTHER changes to the Low alarm adjustment setting) **F2** ALMOFF (turn the alarm off) or **F3** DELAY (adjust the delay time).

The delay time postpones the controller from reporting an alarm unless the sensor is in the alarm state for the number of minutes you choose here.

To adjust the High and Low values:

- 1- Use arrows to adjust the high alarm value as needed. Press **F1** OTHER to switch to the low alarm.
- 2- Use the arrows to adjust the low alarm and press **OK** to save.

To turn the alarm off:

Press **F2** ALMOFF

If you wish to edit the delay, press **F3** DELAY

Use the arrows to edit the time in minutes and seconds and press **F1** to SAVE.

### 9.9 Analog Sensor Diagnostics

- 1- Press **MENU**
- 2- Scroll up to I/O Status and press **OK**.
- 3- Use the arrows to find the I/O point you wish to evaluate and press **OK**.
- 4- Press **F3 MORE**, to see the first Diagnostic for this sensor.
- 5- Press the down arrow to scroll through the remaining Diagnostic screens.

List of typical sensor Diagnostics:

- Sensor Type
- Raw Sensor input value
- Gain Multiplier
- Offset Adjustment
- Last alarm
- Current Status

A CTFS sensor will then show the current temperature of the sample water, and if flow is on or off. This page also shows a voltage representing the amount of flow and at what point above which flow is considered ON.

A corrosion rate sensor has a pitting note and lists the metallurgy of the tips.



#### HINT

To see Diagnostic information of any I/O from main display, Press [F1] (STATUS) then scroll to any I/O and use [F3] MORE to scroll through it's parameters



### 9.9.1 pH-ORP Driver card Diagnostics

- To see diagnostic press **F1**
- Use Up/Down Arrow keys to navigate to desired pH-ORP input then press **F3**
- Diagnostic 1: sensor Type pH Sensor
- Diagnostic 3: Gain will change based on calibration
- Diagnostic 4: Offset will change based on calibration
- Diagnostic 5: reports any type of Alarm
- Diagnostic 6: Driver Type, Dual pH or ORP
- Diagnostic 7: Factory Use
- Diagnostic 8: Factory Use (Driver Type and Product Code)
- Diagnostic 9: Driver card Serial Number
- Diagnostic 10: Factory Use
- Diagnostic 11: Driver card Firmware version for example "01.00.02.00"

### 9.9.2 CT (Conductivity, Boiler Cond., Condensate and Temperature) Driver card Diagnostics

- To see diagnostic press **F1**
- Use Up/Down Arrow keys to navigate to desired Analog Conductivity input then press **F3**
- Diagnostic 1: sensor Type (Conductivity, Boiler Cond., Condensate)
- Diagnostic 2: Raw sensor value
- Diagnostic 3: Gain will change based on calibration  $\text{Sensor Value} = \text{Raw} \times \text{GAIN} + \text{OFFSET}$ , for example  $999 \times 0.16 + 0 = 1599 \mu\text{S}$
- Diagnostic 4: Offset will change based on calibration
- Diagnostic 5: reports any type of Alarm
- Diagnostic 6: Driver Type, Dual conductivity
- Diagnostic 7: Factory Use
- Diagnostic 8: Factory Use (Driver Type and Product Code)
- Diagnostic 9: Driver card Serial Number
- Diagnostic 10: Factory Use
- Diagnostic 11: Driver card Firmware version for example "01.00.00.02"
- Diagnostic 19: Temperature Input Value, for example 75F

### 9.9.3 The 4-20mA Input Driver Card Diagnostics

- To see diagnostic press **F1**
- Use Up/Down Arrow keys to navigate to desired 4-20mA Input I/O then press **F3**
- Diagnostic 1: sensor Type (CLE3 Chlorine, CBR

Bromine, CGE Oxidant, CLO Chlorine, CTE Chlorine, Fluorescent, PAA Peracetic, pH Sensor, ORPO Sensor, Temperature, Toroidal Conductivity)

- Diagnostic 2: sensor Raw value,  $11.99\text{mA} = 66.6\%$ , Amperometric sensors use 4-16mA for min and max range
- Diagnostic 3: Gain, changes based on calibration  $\text{Sensor Value} = \text{Raw} \times \text{GAIN} + \text{OFFSET}$ , for example  $11.99\text{mA} \times 0.833 + (-3.333) = 6.655\text{ppm}$
- Diagnostic 4: Offset changes based on calibration, see step 5
- Diagnostic 5: reports any Alarm
- Diagnostic 6: Driver Type, for example Dual 4-20mA input
- Diagnostic 7: Factory Use
- Diagnostic 8: Factory Use
- Diagnostic 9: Driver card Serial Number
- Diagnostic 10: Factory Use
- Diagnostic 11: Driver card Firmware version for example "00.00.00.17"
- Diagnostic 14: Sensor Range for example 0-10ppm

### 9.9.4 The 4-20mA output Driver Card Diagnostics

- To see diagnostic press **F1**
- Use Up/Down Arrow keys to navigate to desired 4-20mA output I/O then press **F3**
- Diagnostic 1: sensor Type 4-20mA output
- Diagnostic 3: Gain will change based on calibration
- Diagnostic 4: Offset changes based on calibration
- Diagnostic 5: reports any type of Alarm
- Diagnostic 6: Driver Type, Dual 4-20mA Output
- Diagnostic 7: Factory Use
- Diagnostic 8: Factory Use (Driver Type and Product Code)
- Diagnostic 9: Driver card Serial Number
- Diagnostic 10: Factory Use
- Diagnostic 11: Driver card Firmware version for example "00.00.00.01"

### 9.9.5 Serial Sensors (CTFs, LPR, DP) Driver Card Diagnostics

- To see diagnostic press **F1**
- Use Up/Down Arrow keys to navigate to desired I/O then press **F3**
- Diagnostic 1: sensor Type (Conductivity, Corrosion, Differential Pressure)

---

## Programming the Inputs

---

- Diagnostic 2: sensor Raw value
- Diagnostic 3: Gain, changes based on calibration
- Diagnostic 4: Offset,
- Diagnostic 5: reports any Alarm
- Diagnostic 12: if sensor connected it will display (Sensor OK Connected) if no sensor connected to terminals (Sensor disabled Disconnected)
- Diagnostic 13: will display phantom input Temperature value and also if the Thermal flow switch is ON/OFF.  
In this example Flow value should be higher than 960 to display Flow ON.

*Note: Sensor Value = Raw x GAIN + OFFSET  
For example = 235 x 8.5 + 0 = 1998 uS about 2000 uS*

## 9.10 Configuring Digital Inputs

### 9.10.1 Configure a Digital Input as a Water Meter:

NOTE: All digital inputs O-V can be configured for a pulsing water meter

- 1- To Enable and Set digital input press **MENU**
- 2- Scroll to **System** and press **OK**
- 3- Scroll to Enable I/O and press **OK**
- 4- Scroll to select the desired input (O through V) and press **F3**
- 5- Press **F3** again to switch from METER to CONTACT if necessary, then press **OK**

- 6- Press **MENU**
- 7- Scroll to Water Meter Setup then press **OK**
- 8- Scroll down to your meter, then press **OK**
- 9- Use **F3** to switch to Vol/Contact if necessary, then use Up/Down and Left/Right arrow keys to set gallon per contact or to adjust the K factor, then press **F1** to SAVE.

**Note:** See 9.2 [Naming an Input or Output](#) to rename the relay for example to "Makeup Flow"

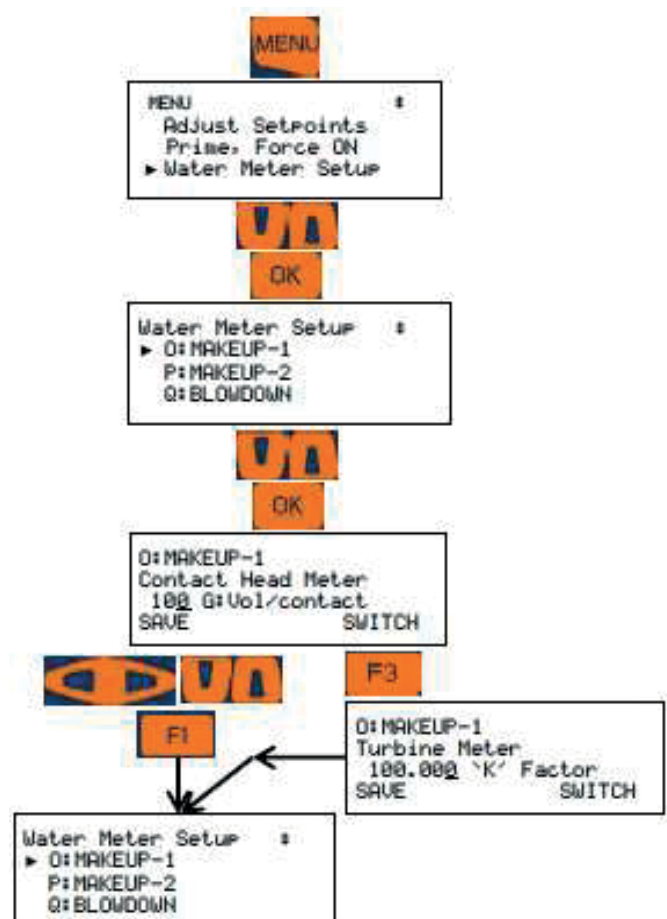
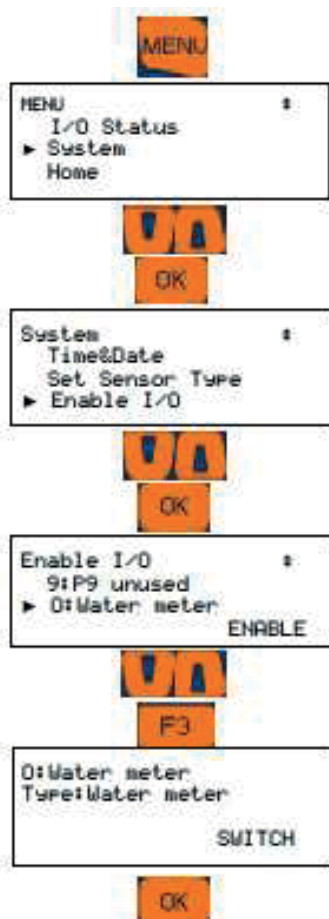

# Programming the Inputs

## 9.10.2 Link a Water Meter to a Relay (Applies to all relays )

Relays must be configured for Feed mode. See 10.6

Frequency relays set for ON/OFF mode are configured the same as relays 1-5. See example A.

For pulse output relays, use example B.

- 1- Press **MENU**
- 2- Scroll to **Set Feed Mode** then press **OK**
- 3- Scroll to the desired relay. Press **OK**
- 4- Select the Feed Mode type: Water Meter and press **OK**
- 5- Scroll to select the meter and press **F1** to Select and then **OK**
- 6- Use arrow keys to edit the measure value
- 7- Press the **F1** key, OTHER, to move to the Feed volume value.
- 8- Set the relay ON time in seconds or a PPM set-point.
- 9- Press **OK** to save

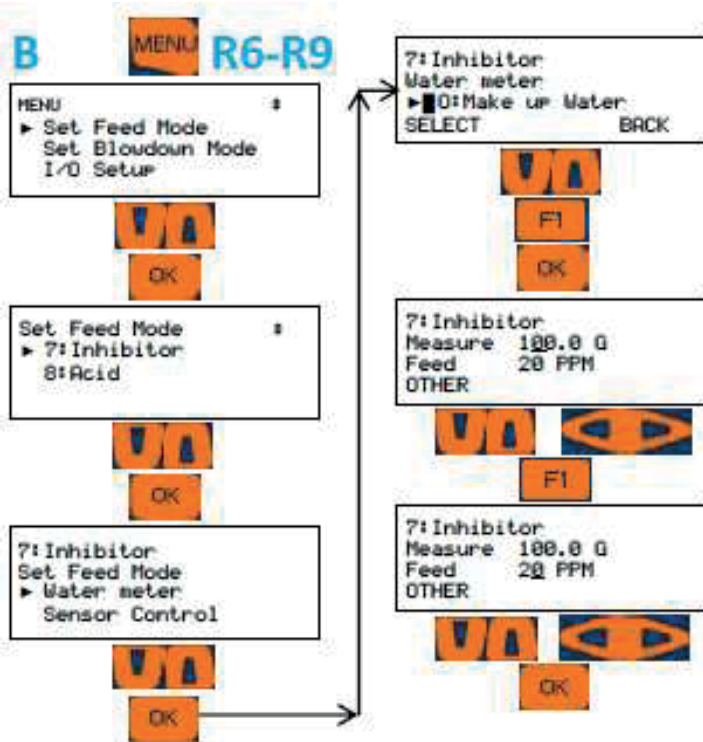
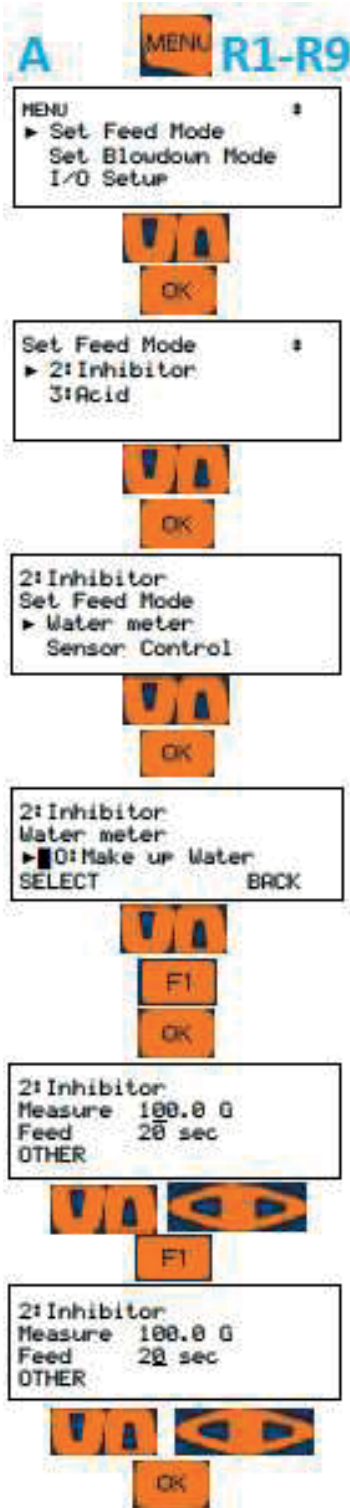

9.11 Disable an Analog or Digital Input

- 1- Press **MENU**
- 2- Scroll down to **I/O Setup** and press **OK**
- 3- Scroll down until you locate your sensor analog or digital, and press **OK**. (This example shows an analog input)
- 4- Scroll down to **Configure** and press **OK**
- 5- If the sensor is not currently being used to control a relay, you can disable it. Scroll down to **Disable** and press **OK**.
- 6- If the sensor is in use by a relay, scroll down to **Used by I/O** to see which relay is using the sensor. Press **ESC** (Escape).

Inputs linked to outputs cannot be disabled.

If necessary, use the next sections to unlink the output, then return to this menu to disable the input.

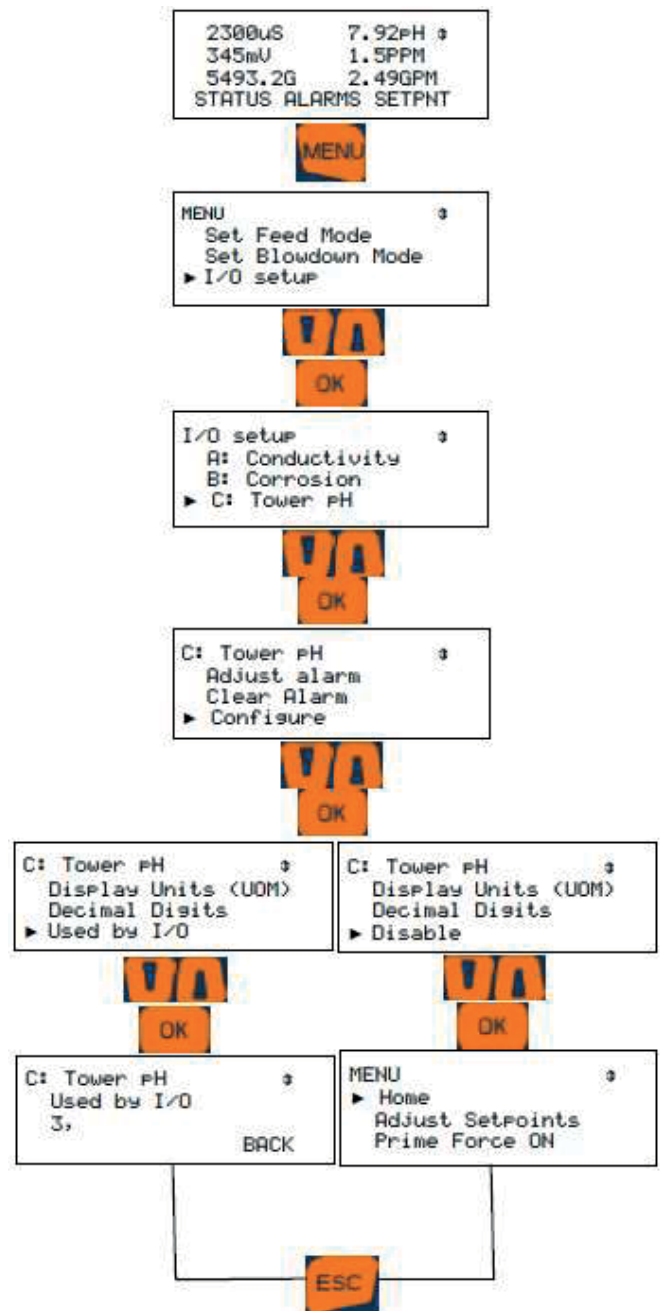

## Programming the Outputs

### 9.11.1 Changing or Unlinking an Analog Input Tied to an Output Relay

Inputs linked to outputs must be un-linked prior to being disabled.

Analog inputs tied to Feed type relays, use pictogram **A**, Blowdown type use **B**, and Event – other use **C**.

- 1- Press **MENU**
- 2- Scroll down to Set Feed Mode if used to control a pump or Set Blowdown Mode if the relay is used for bleed. Press **OK**
- 3- (Examples of each type)
- 4- Scroll down to the relay indicated in the 'In Use' menu (Step 6 in 9.11) and press **OK**.
- 5- Change the relay to a different type of control program, press **OK** and skip to step 6, or press **OK** for Sensor Control
- 6- Scroll up or down to the new sensor and press **OK**
- 7- Press **F1**, 'Select' to save this choice.
- 8- Press **ESC**, Escape

Return to the 9.11 Disable an Analog or Digital Input menu, to finish.

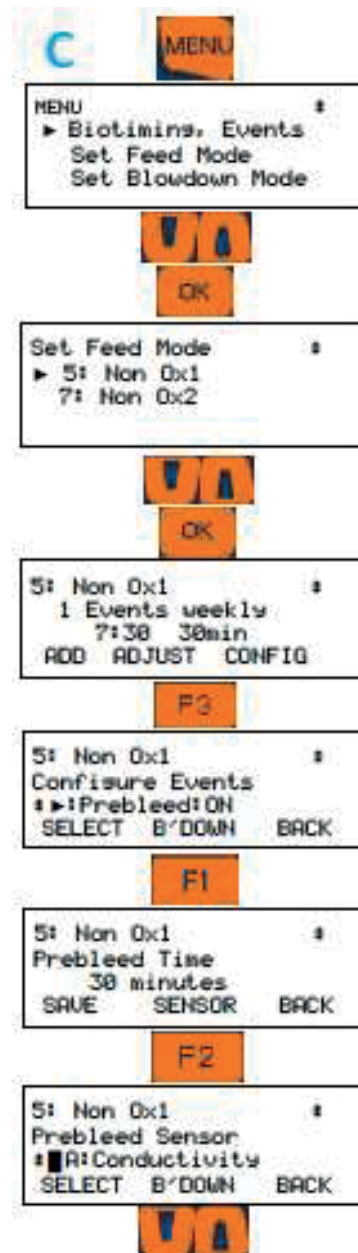
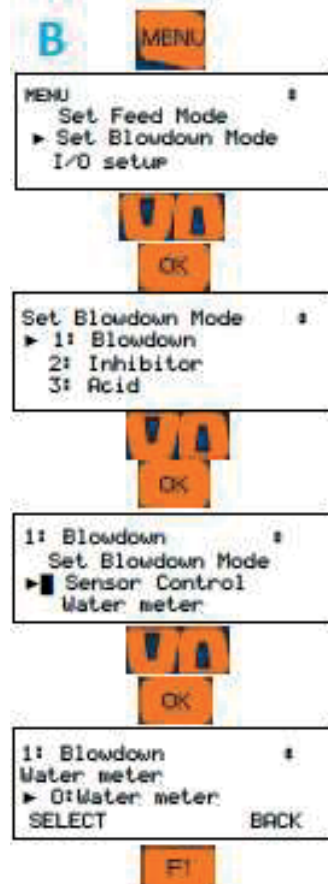
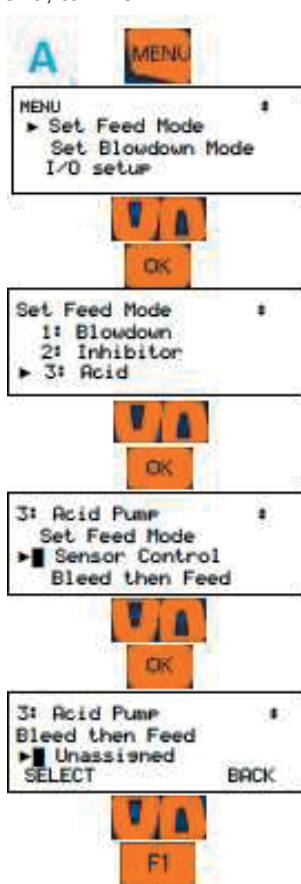

## 9.11.2 Changing or Unlinking Analog Inputs Tied to a 4-20mA Output:

Relay outputs are designated by their number, 1 through 9. 4-20mA outputs can be letters C, D, E, F, I or J. This procedure can be used to change the input that the mA output represents, or you can choose 'None'.

Inputs linked to outputs must be un-linked prior to being disabled.

- 1- Press MENU
- 2- Scroll down to I/O Setup and press OK
- 3- Scroll down to the output letter and press F2, 'NEXT'.
- 4- Use the up or down arrows to choose another input, or choose 'None' and press OK.
- 5- Press ESC (Escape).

If unlinking an analog input so as to disable it, return to the [9.11 Disable an Analog Input](#), to finish.

## 9.11.3 Changing or Unlinking a Digital Input Tied to a Digital Output

If a digital input is used as an interlock for a relay, it must be unlinked prior to being disabled.

- 1- Press Menu
- 2- Scroll down to I/O Setup and Press OK
- 3- Scroll down to the relay or 4-20mA Output where the interlock is being used. Press OK.
- 4- Scroll down to Interlock and press OK
- 5- Press F1 (Remove) to unlink the digital input from this output.
- 6- Choose a new interlock or press OK to save the change. If more than one interlock, use the arrows to see them and remove as needed. Escape will void all changes.

See also [10.8 Interlocks](#)

Return to [9.11 Disable an Analog or Digital Input](#) to finish

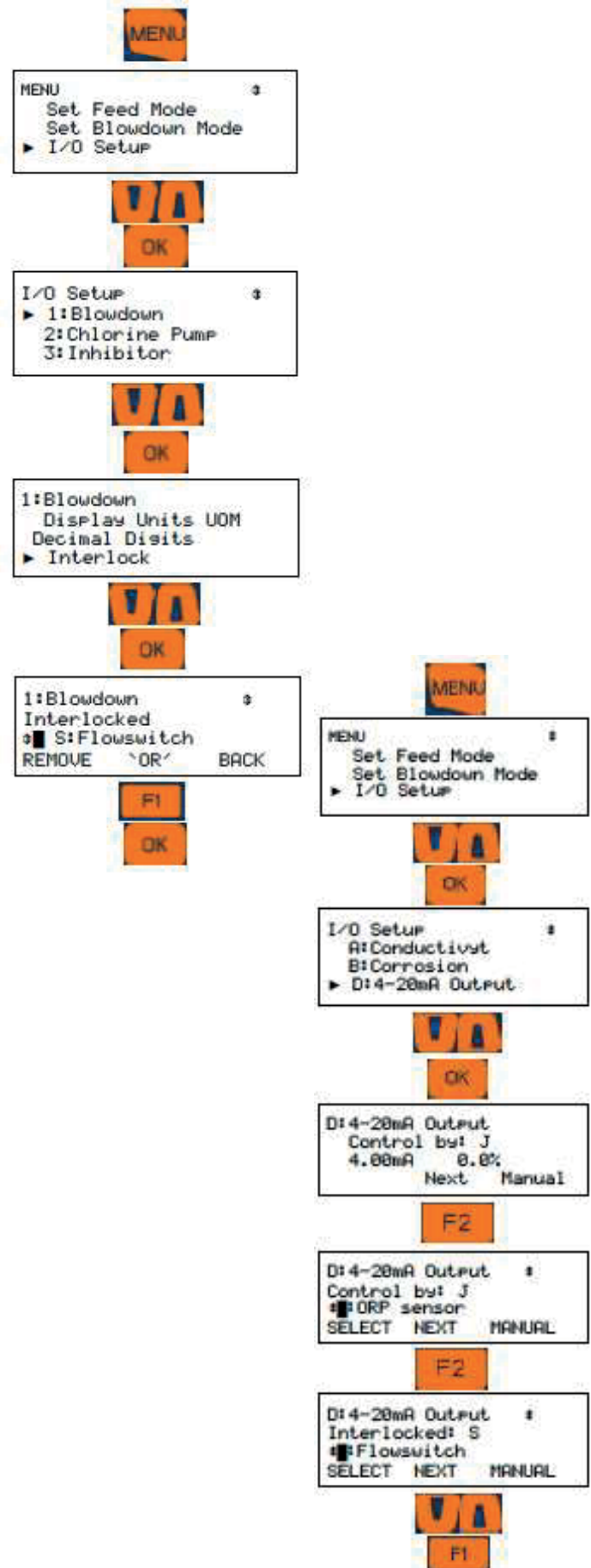

## Programming the Outputs

### 9.11.4 Changing or Unlinking a Digital Input Tied to a 4-20mA Output

If a digital input is used as an interlock for a relay, it must be unlinked prior to being disabled.

- 1- Press **MENU**
- 2- Scroll down to I/O Setup and Press **OK**
- 3- Scroll down to the 4-20mA Output where the interlock is being used. Press **OK**.
- 4- Press **F2** Next two times to get to the Interlocks
- 5- Press **F1** (Remove) to unlink the digital input from this output.
- 6- Choose a new interlock or press **OK** to save the change. If more than one interlock, use the arrows to see them and remove as needed. **ESC**, Escape will void all changes.

See also [10.8 Interlocks](#)

Return to [9.11 to Disable an Analog or Digital Input](#).

### 9.12 Phantom Inputs

The Aegis has a maximum of 10 analog inputs, A through J. Analog inputs are linked to the first 14 letter of the alphabet, A through N, which means 4 letters, K through N cannot be assigned to any wired input. They have no terminals. These are phantom or virtual analog inputs.

Digital Inputs are lettered from O to Z. Wired inputs are labeled from O to V. Input designators W, X, Y and Z can be used as phantom digital inputs.

In some cases it is advantageous to create a phantom sensor to duplicate an existing hardware sensor. Another use is to assign a phantom “virtual” input to show and data log a temperature sensor or flow switch that is an integral part of another sensor. We use the common CTFs sensor as an example to highlight how this is done. See 9.1.2 Enable a CTFs

Any analog input, including Phantom’s, can be used as a manual input to data log operator test data. If you test the water each turn, you can log that value into this controller. It will be time stamped and is part of the complete historical database with all sensors, phantoms and relays.

Analog phantoms can be programmed to be used in control outputs in the same manner as any sensor input.

## 10 Programming the Control Outputs (Relay and 4-20mA)

This section will describe how to configure relays to control a process and 4-20mA outputs for control or as an indication of an analog input sensor. Outputs can be based on a sensor with ON/OFF set-points, a timed event, a combination of an event and a sensor, base feed, percent timer, bleed and then feed and more options. These can include interlocking with digital inputs, blocks from other relays and a few special controls. Special Controls include the boiler captured sample routine, variable cycles, timed cycling, time modulation and PID.

The part number and identification code on the order placed with ProMinent will determine the sensors and outputs that were configured as default at the factory. Some sensors may have been pre-wired, (pH and ORP coaxial cables, some conductivity and temperature sensors, ppm residual sensors). Other sensors like water meters and chemical feeders may have been configured, but will have to be field installed, wired, enabled and possibly re-configured during commissioning.

**Note1:** Relays can be enabled as one of three types; Blowdown, Events-Other or Feed. Once a relay is enabled, the only way to change the assignment from one to another is to disable the relay and enable it as a different usage.

The B'DOWN (Blowdown) choice means that the relay must be linked to a conductivity sensor, which can include a 4-20mA input from our toroidal probe. The output will turn on and off based on set-points.

The Events-Other and Feed choices require further

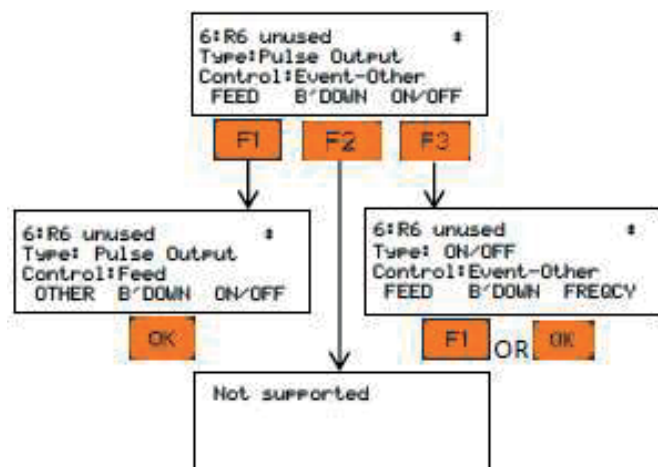

programming as well. These steps are explained in detail later.



**Note2:** When an output is disabled and then re-enabled, the control is reset and all user control settings removed. This action puts the relay control into a defined state prior to reconfiguring.

A sensor input can be used as an analyzer or monitor, but to be able to control a feeder or a valve, it needs to be linked to an output. Linking is achieved in the configuration process. See Section [10.6 Configuring a feed relay](#)

## 10.1 Frequency/Pulse Outputs:

Frequency controlled Pumps feed chemicals at varying rates (Frequency controlled pumps are outputs 6 to 9)

Any analog sensor: temperature, flow, corrosion rate, ORP... may be used to frequency control a pulse controlled pump. The output is proportional to the input sensor using part or all of the sensor range.

Example: Using a pH sensor with an input of 0 to 14pH, you could set 0 pulses at 14pH and maximum pulses at 0pH. The higher the pH, the slower the output pulses.

Or you could set the output as a range of 0 pulses at 7.2pH and maximum pulses at 7.8pH. This shortened range would cause the pump to speed up and down more rapidly with changes in pH and is in the opposite direction as you might use on an acid pump.

Pump speed control is achieved without using a 4-20mA pump.

Alarm settings for Volume @Max SPM (Strokes per Minute) and Volume/Day are limited to 500 Gallons. These alarms are adjustable in the output alarm menu.

The alarm for volume @ maximum strokes per minute was created for the situation where a pump is at full speed for too long a period of time. For example, an acid pump that cannot lower the pH enough to slow the pump from the maximum speed after say 10 minutes, might be considered an alarm condition. Waiting until the pump feeds more than the volume per day would be much too long. If you calculate the pump is feeding, for example, 24 GPD at 100% speed, you know that setting the Volume @ max stroke will alarm in one hour if set for 1 gallon. (24GPD / 24 hours = 1 GPH). So if you want the pump to alarm after 10 minutes, enter 1/6<sup>th</sup> of a gallon, or 0.1667G and if the pump runs at 100% for 10 minutes, it will have pumped 0.1667 gallons and trip the alarm.

The Four OptoMOS DOs(Digital/Frequency Outputs)

P6,P7,P8, & P9 can each be set to either:

- 1- Pulse output/Frequency
- 2- ON/OFF

**Note:** this setup is done during the enabling of the output.

Output relays, once configured, must be disabled and re-enabled if you need to change their type. See section [10.3 Enable and Configure a Relay](#).

## 10.2 Determine if a Relay is Enabled:

- 1- From the Home display, press the **F1** STATUS key.
- 2- Scroll through the enabled I/O. If you **do not see** your relay, it is disabled.



## 10.3 Enable and Configure a Relay

- 1- Press the **MENU** key
- 2- Use the ARROW keys to scroll to System then press **OK**.
- 1-
- 2-
- 3- Scroll up to Enable I/O then press **OK**
- 4- Scroll through the disabled I/Os until you see your relay.
- 5- Once the output is selected, press **F3** ENABLE key.  
To complete the **enable** process, you must choose a relay type.

### NOTICE

This naming/Descriptor procedure is the same for all I/O points; Inputs and Outputs, digital and analog and that also includes 4-20mA ports.

# Programming the Outputs

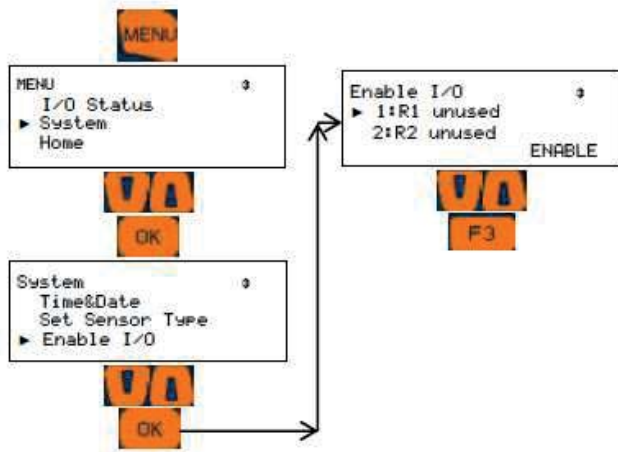

This menu shows the default type of output as “ON/OFF” and the control as “Events-Other”. ON/OFF is the only choice for the first 5 relays.

Relays 6 – 9 can be either ON/OFF or frequency type.

Step 6 is divided into two methods; the first for relays 1 – 5 and the second for pulse relays 6 – 9.

**6a- For AC-Powered Relays 1 – 5 programming:**  
 Choose which type of relay program you wish to use, F1 for Feed pump, F2 for a Blowdown relay or press OK to keep the Event-Other choice. Follow F1 or F2 with an OK to select the control.

**6b-For DC (Pulse) Relay programming:**

If you desire an ON/OFF output, press OK to choose the Event-Other menu type or F1 for Feed type. Press OK to save the change.

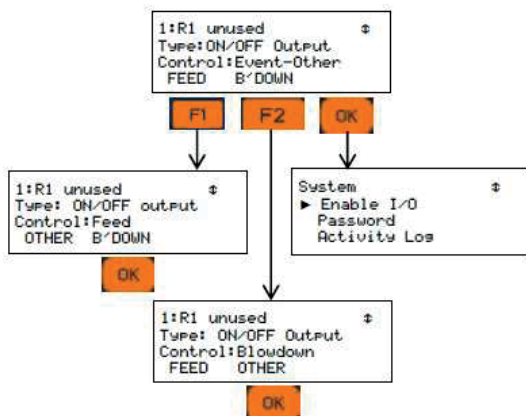

At this time, we recommend naming the relay to avoid confusion during programming. Once named, we will set up the remaining relay attributes.

## 10.4 Naming the Output

In section 10.3, we showed how to enable a relay. Regardless of the type of relay you choose, the next step is to name it.

Pick a name that identifies the relay for you or your customer; Blowdown, Acid, LJ25X, Amine, etc.

- 1- Press **MENU**.
- 2- Scroll down to I/O Setup. Press **OK**.
- 3- Scroll down to the relay you chose to name and press **OK**. If your relay is not listed, it is not enabled.
- 4- See [10.2, Determine if a Relay is Enabled](#).
- 5- Press **OK** to edit the description of the relay.

Please notice that the F2 key represents the word 'alpha'.

You have three choices, **ALPHA** (upper case letters), **alpha**, (lower case letters), and **NUMBERS**, 0 through 9. Since the lower case 'alpha' is seen, please realize that this is a choice, not the current

- 6- Use the right arrow to move to the second position. Press the F2 key to choose **alpha**, lower case letters. Notice that the F2 choice now shows NUMBERS. That would be the next choice.
- 7- Use the arrows to change the next letter/space and continue until your word is spelled.
- 8- When finished, press OK to save.

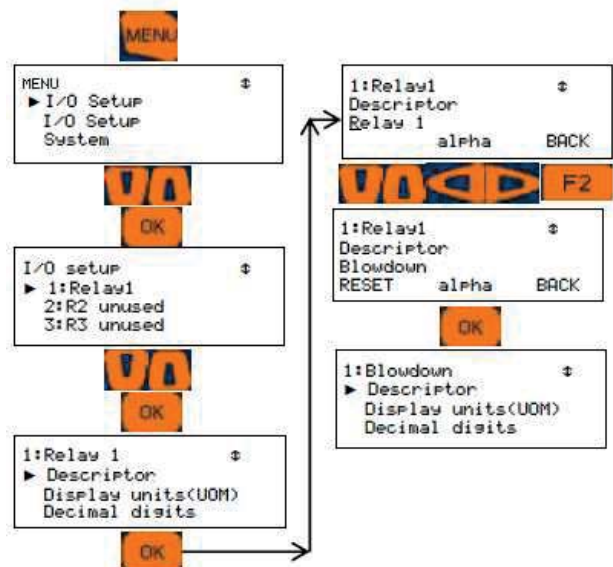

**B'down** will set up the output for a blowdown. You will need to identify the conductivity sensor in this process. If the conductivity sensor is not currently enabled, enable and configure it first. See [9.1.1 Enable an Analog or Digital Input](#), and [10.5 Configuring a Blowdown Relay](#).

The **Feed** option prepares the output for a chemical pump based on a sensor or water meter. See [10.6 Configuring a Feed Relay](#)

**Event-Other** is used to configure a timed event relay. Timed events are frequently used for non-oxidizing biocides. See [10.7 Configuring an Event-Other Relay](#)

Each of these relay types have special control functions available.

Blowdown has Captured Sample, (section [10.12.2](#)) and Varying Cycles, (section [10.12.3](#)). Feed has three types; Timed Cycling, [10.11.1](#), Time Modulation, [10.11.2](#), and PID, [10.11.3](#).

Event-Other has Prebleed/lockout. This is not shown as a separate option. It is included with the [Configuring an Event-Other relay](#) in section [10.7](#)

## 10.5 Configuring a Blowdown Relay

If you have not named the relay, See section [10.4 Naming the Output](#). If you have not enabled the relay, see section [10.2 Determine if a Relay is Enabled](#).

Blowdown relays require the use of a conductivity sensor. See section [9.1.1 Enable an Analog or Digital Input](#).

Relays set for Blowdown mode have the following options; Simple bleed based on conductivity set-points, reverse conductivity/inhibitor feeding or the special control method using our boiler Captured Sample routine.

Simple bleed is used on cooling tower applications and large boilers that incorporate continuous blowdown.

Boilers are covered in more detail in section [10.11 Special Control Functions](#)

Invert the control action to feed inhibitor based on conductivity, see section [10.10 Control Action](#).

To control blowdown on standard boilers, see [10.12.2 Captured Sample](#).

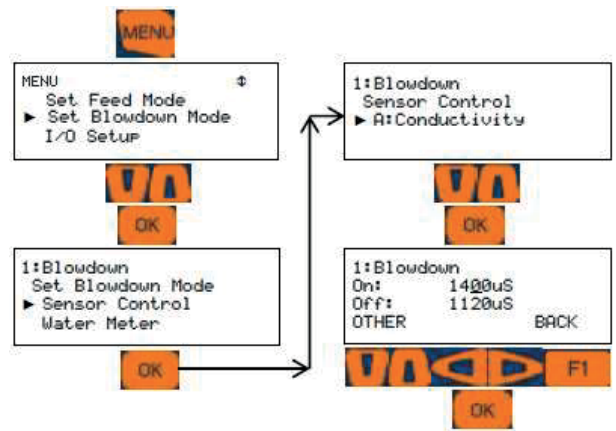

Simple blowdown:

- 1- Press **MENU** and scroll down to **Set Blowdown Mode**. Press **OK**.
- 2- If more than one relay is set for this mode, chose the one you are working on and press **OK**.
- 3- Press **OK** for **Sensor Control**
- 4- Scroll down to your conductivity sensor, if necessary, and press **OK** to select it.
- 5- Enter the ON and OFF set-points. Use the UP and DOWN arrows to edit the underlined digit. Use the RIGHT and LEFT arrows to move between the digits. Press OTHER to switch between the ON and OFF set-points.
- 6- Press **OK** to save and exit.

Use the I/O Setup screen to set [interlocks](#) and [blocks](#). See [10.8](#) and [10.9](#).

## 10.6 Configuring a Feed Relay

If you have not enabled the relay, see section [10.2 Determine if the Relay is Enabled](#) and/or [10.3 Enable and configure a Relay](#). If you have not named the relay, See section [10.4 Naming the Output](#).

There are three relay modes; **Blowdown, Feed, and Event/Other**. There are five types of **Feed Relay** choices;

- Feed based on a water meter,
- Feed based on any analog sensor including any 4-20mA input,
- Bleed and/or Feed,
- Using a percent timer or
- Using a sensor during an event.

## Programming the Outputs

The next sections of this manual, 10.6.1 through 10.6.5, show how to set up these types of feed.

### 10.6.1 Feed Based on a Water Meter

A water meter feed lets you choose how long to run a pump or feeder based on a particular number of gallons or liters accumulated on a meter. Change the set-points anytime to adjust the amount of chemical feed.

Prior to these program steps, you need to enable a water meter input. See [9.1.1 Enabling an Analog or Digital Input](#) and [10.3 Enable and Configure a Relay](#).

- 1- Press **MENU**, then
- 2- Scroll down to Set Feed Mode and press **OK**
- 3- Scroll down to the relay you wish to configure and press **OK**.
- 4- Scroll down to Water Meter and Press **OK**.
- 5- Scroll down to the water meter you will be basing the feed upon and press **F1**, (Select). A box will appear on the display to the left of the input. Press **OK**.
- 6- Use the arrows to edit the number of gallons needed to start the feed timer, then edit the feed time value. Use the **F1** OTHER key to toggle between these values.
- 7- Press **OK** to save.

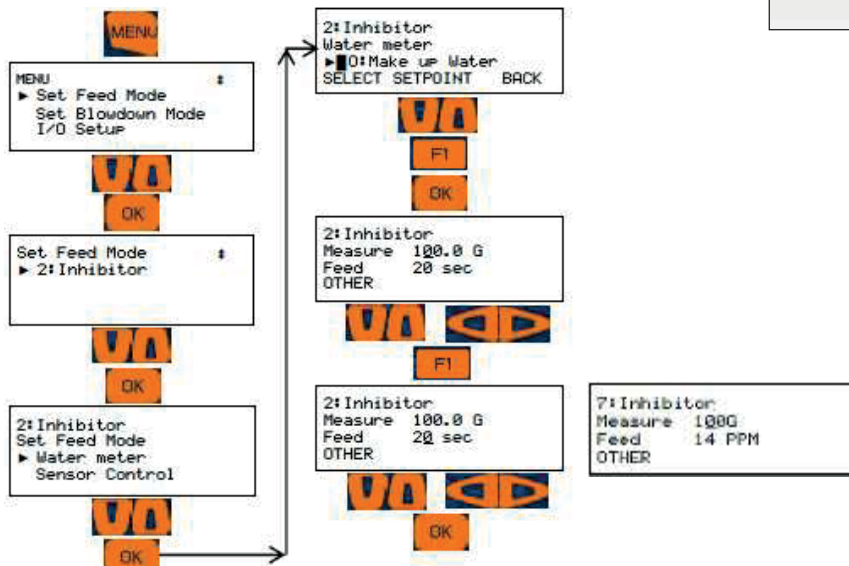

If you have a pulse frequency output relay, the feed choice will not be in seconds, it will be in PPM. Based on the size of the pump, the controller will pulse the output until the calculated amount of milliliters is dispensed.

**Pulse outputs 6-9** use a PPM set-point, not time.

### 10.6.2 Feed Based on a Sensor

(See also [10.6.5 Feed Based on a Sensor with Event Control](#))

A sensor based relay will turn on a pump or valve depending on the ON and OFF set-points you set for this relay.

Prior to these program steps, you need to enable an analog sensor input. See [9.1.1 Enabling an Analog Input](#) and [10.3 Enable and Configure a Relay](#).

- 1- Press **MENU**.
- 2- Scroll down to Set Feed Mode and press **OK**
- 3- Scroll down to the relay you wish to use and press **OK**.
- 4- Scroll down to Sensor Control and press **OK**.
- 5- Scroll down to the sensor you wish to use and press **F1**, Select.
- 6- Use the arrows to edit the On set-point. Press **F1**, OTHER to toggle between the On and Off values.
- 7- Press **OK** to save.

 Pulse outputs use a proportional range to control the speed of the pulses to the pump.

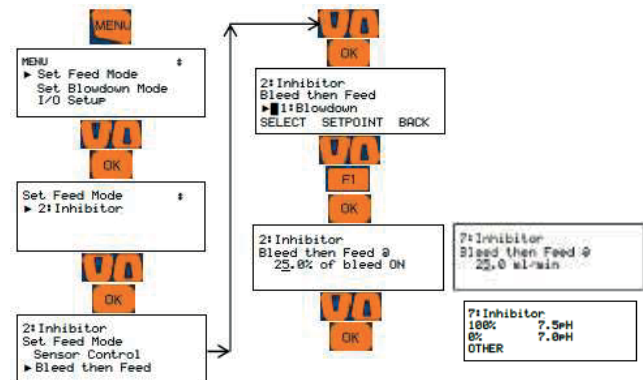
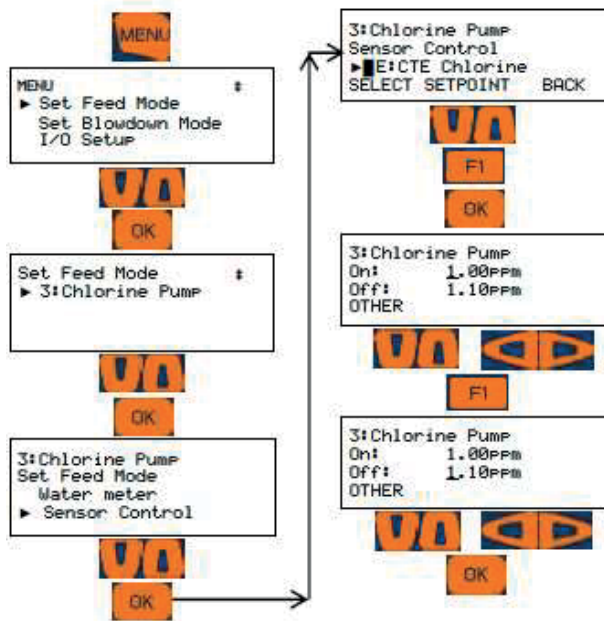

### 10.6.3 Feed Based on Bleed and/or Feed

The Aegis II has two feed modes based on how long the bleed valve is open. The Feed relay in the **Bleed then Feed** program will wait until the Bleed is complete, then calculate how long to feed based on the percentage selected.

Prior to configuring these program steps, you need to enable a Blowdown relay. See section [9.4 Configuring a Blowdown Relay](#). If you have not enabled the Feed relay, see section [9.5 Configuring a Feed Relay](#)

#### 10.6.3.1 Bleed then Feed

- 1- Press **MENU**.
- 2- Scroll down to Set Feed Mode. Press **OK**
- 3- Scroll down to the relay you wish to use to control the pump. Press **OK**.
- 4- Scroll down to the Bleed then Feed choice and press **OK**.
- 5- Scroll down to the blowdown valve you will be using and press the **F1, Select**.
- 6- Press the **F2, SETPNT** key.
- 7- Use the arrows to edit the % value per the above explanation. Press **OK** to save.

A **pulse relay** will feed X milliliters per minute.

#### 10.6.3.2 Bleed and Feed

The Aegis II has two feed modes based on how long the bleed valve is open.

The Feed relay in the **Bleed and Feed** program is based on a 5 minute time frame. The controller calculates how long the feed pump should be on based on 300 seconds X the percentage entered and starts to feed when the remainder of the 300 second bleed equals this calculated amount. Example: If the percent is 80, the controller calculates 80% of 300 or 240 seconds, then starts the feed when the bleed count down reaches 240 seconds. Both relays will count down to zero. The feed relay will stop. The bleed will reset to 300 seconds and continue counting down.

When the bleed stops, the feed stops and the counters are reset.

Prior to configuring these program steps, you need to enable a Blowdown relay. See section [10.5 Configuring a Blowdown Relay](#). If you have not enabled the Feed relay, see section [10.6 Configuring a Feed Relay](#)

- 1- Press **MENU**.
- 2- Scroll down to Set Feed Mode. Press **OK**.
- 3- Scroll down to the relay you wish to use to control the pump. Press **OK**.
- 4- Scroll down to the Bleed then Feed choice and press **OK**.
- 5- Scroll down to the blowdown valve you will be following and press the **F1, Select** key.
- 6- Press the **F2, Set-point** key.
- 7- Use the arrows to edit the % value per the above explanation. Press **OK** to save.

## Programming the Outputs

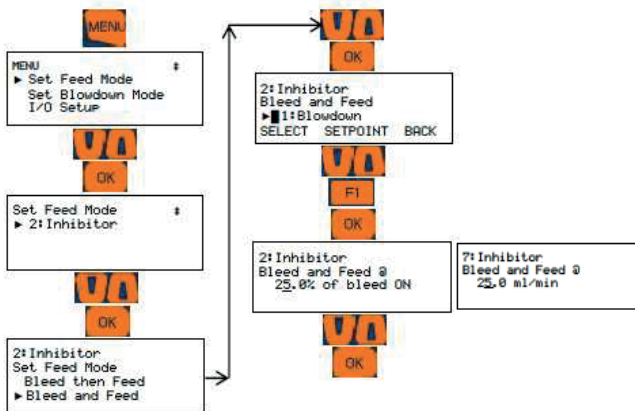

Rather than a percentage, a pulse relay will show X milliliters per minute.

### 10.6.4 Feed Based on Percent Time & Base Feed

This method applies to the first 5 relays and the pulse relays when programmed for ON/OFF mode.

The Percent Time program is based on a 5 minute time frame. The controller calculates the percent of 300 seconds and will turn on the feed relay for that calculated time. Each 5 minutes, the calculated time is again applied to the feed relay.

If you have not enabled the Feed relay, see section 10.6 Configuring a Feed Relay.

- 1- Press **MENU**
- 2- Scroll down to Set Feed Mode and press **OK**.
- 3- Scroll down to your feed relay and press **OK**.
- 4- Scroll down to Percent Time and press **OK**.
- 5- Use the arrows to edit the percentage and press **OK** to save and exit.

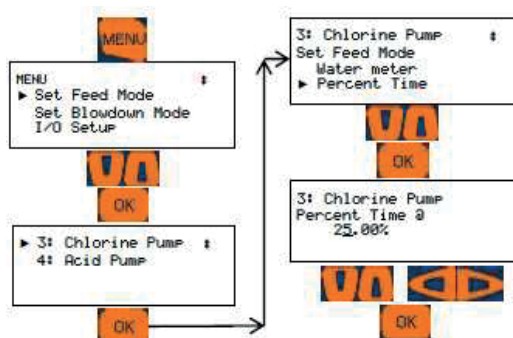

A pulse relay in frequency mode also has a base feed option

Choose Base Feed and enter the milliliters per minute rate. This pump will then feed constantly at that rate.

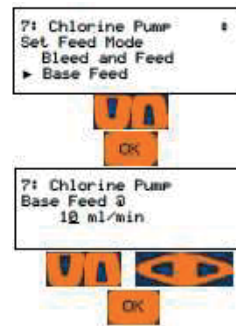

### 10.6.5 Feed Based on a Sensor with Event Control

Relays in Feed mode can have an Event Control whereby the relay will control based on a sensor but only during the event time.

### 10.6.6 Set up a relay using the Feed mode with an oxidant sensor; ORP or any 4-20mA input.

Use section [10.6 Configuring a Feed Relay](#) then use [10.7 Configuring an Event-Other Relay](#) for the event portion.

### 10.6.7 Choosing a Cycle

- 1- Press **MENU**. Scroll down to Biotiming, Events and press **OK**
- 2- Scroll down until you see your relay and press **OK**. If you do not see your relay, it is not enabled. See [10.3 Enable and Configure a Relay](#)
- 3- If you do not have any events, you can choose to add an event or configure the relay. Press **F3 CONFIG** to configure the relay.
- 4- The configure menu allows you to set up a Prebleed, a Lockout and the Cycle. Scroll down to Event Cycle and press **F1** to SELECT. We will cover Prebleed and Lockout in the next section; [10.7.1 Schedules, Prebleeding, Lockout and With a Sensor](#)
- 5- Use the right and left arrows to pick Daily, Weekly or 28 day cycles. Press **F1** to Select.

These menus are the same for Pulse relay event configuration.

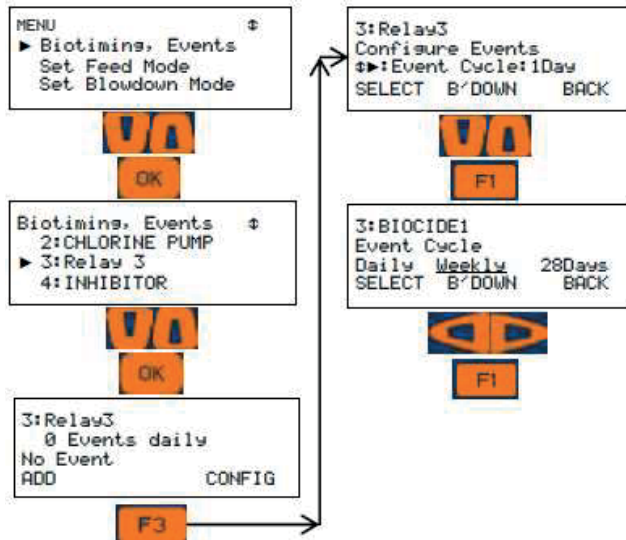

feed is delayed by this action.  
If you have not enabled the Feed relay, see section [10.6 Configuring a Feed Relay](#)

Use an event in conjunction with a sensor to limit ON time during the event. See [9.5.5 Feed Based on a Sensor with Event Control](#)

### 10.7.1.1 Prebleed/Lockout

The following steps are a continuation of [10.7.1 Schedules, Prebleeding, Lockout and With a Sensor](#)

If your event does not require a Prebleed or Lockout, skip to section [10.7.2.1 Adding Events](#)



## 10.7 Configuring an Event-Other Relay

### 10.7.1 Schedules, Prebleeding, Lockout and With a Sensor

Events are typically used to feed biocides on a pre-determined schedule with weekly or daily schedules being the most popular. An example might be; Every Monday feed biocide A for 20 minutes at 7 AM, then feed biocide B every Thursday, for 25 minutes at 7 AM. You can choose a 28 day cycle to accommodate feeding every other week.

Schedules generally do not follow a calendar. Daily choices repeat every day. If you choose the 28 day cycle, the next screen will tell you which week you are in, 1 – 4. Weekly entries match a weekly calendar. Sunday is day 1 and Saturday is day 7.

Any event has an option to configure prebleeding and/or lockout to maximize the effect of the product. The idea of locking the bleed valve during and after feeding a non-oxidizing biocide improves effectiveness by increasing contact time.

Programming a prebleed ensures that the tower not cycle up above the blowdown set-point avoiding a scaling situation. The prebleed setup will open the bleed valve until a timer has expired or a low conductivity set-point is reached. The

NOTE: In addition to a feed relay, this procedure requires the use of a blowdown relay. See section [10.5 Configuring a Blowdown Relay](#)

- 1- From the Daily, Weekly or 28 Day screen, choose **F3** CONFIG as before.
- 2- Press **F1**, Select to choose Prebleed
- 3- Scroll down to find the blowdown relay and press **F1** to SELECT it
- 4- Scroll down to find the Conductivity sensor and press **F1** to SELECT it.
- 5- Press **F3** to return to the Configuration menu and **F1** to Select Prebleed again.
- 6- Use the arrows to adjust the Prebleed time. Press **F1** to SAVE
- 7- Press **F3**, Config.
- 8- Press **F1** to choose Lockout
- 9- Use the arrows to edit the lockout time. This value should include the feed time of the pump. It is not the length of time after the pump stops.
- 10- Press **F1** to Save.

We are now ready to add events to the relay. The relay should be named as well to avoid confusion.

**This menu is the same for Pulse relay event configuration.**

## Programming the Outputs

### 10.7.2 Add, Remove, Edit Events

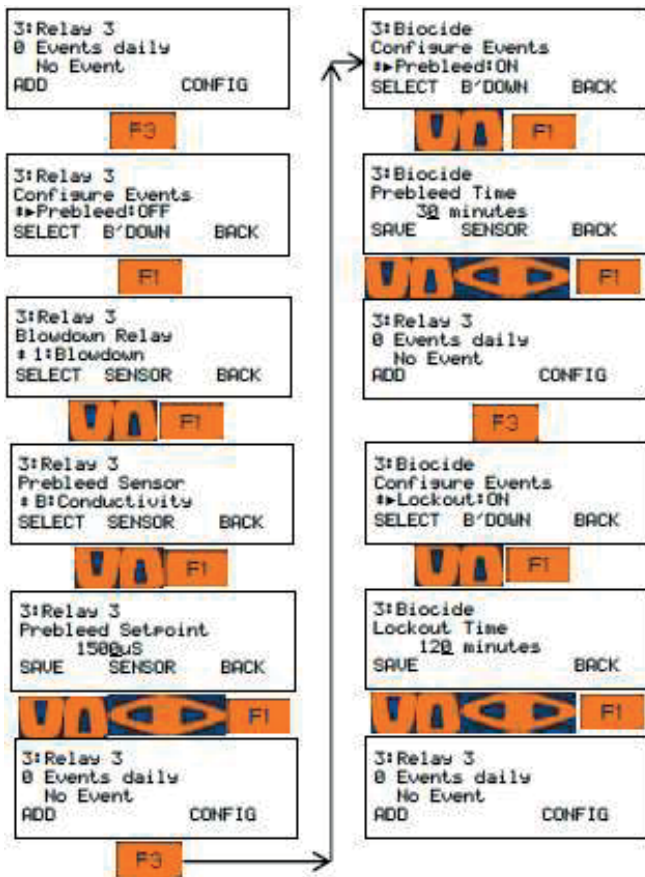

#### 10.7.2.1 Adding Events

Once a relay is enabled as an Event – Other output, you can add, remove or edit events. From the Prebleed/Lockout menu, press F1 Add. If you are not in that menu, press the Menu key and scroll down to Biotiming, Events and press OK. Scroll down to your relay and press OK again. Press F1 Add. Depending on the cycle chosen, you will see slightly different screens. Follow your cycle below.

- 1- The Add screen presents a default day, start time and pump ON time. Use the arrows to edit these values and press F1 to save the changes.
- 2- Use the left/right arrows to choose a frequency. ONCE will enter only the event you set. It will repeat each cycle. (Once a day, once a week or once every 4 weeks.)



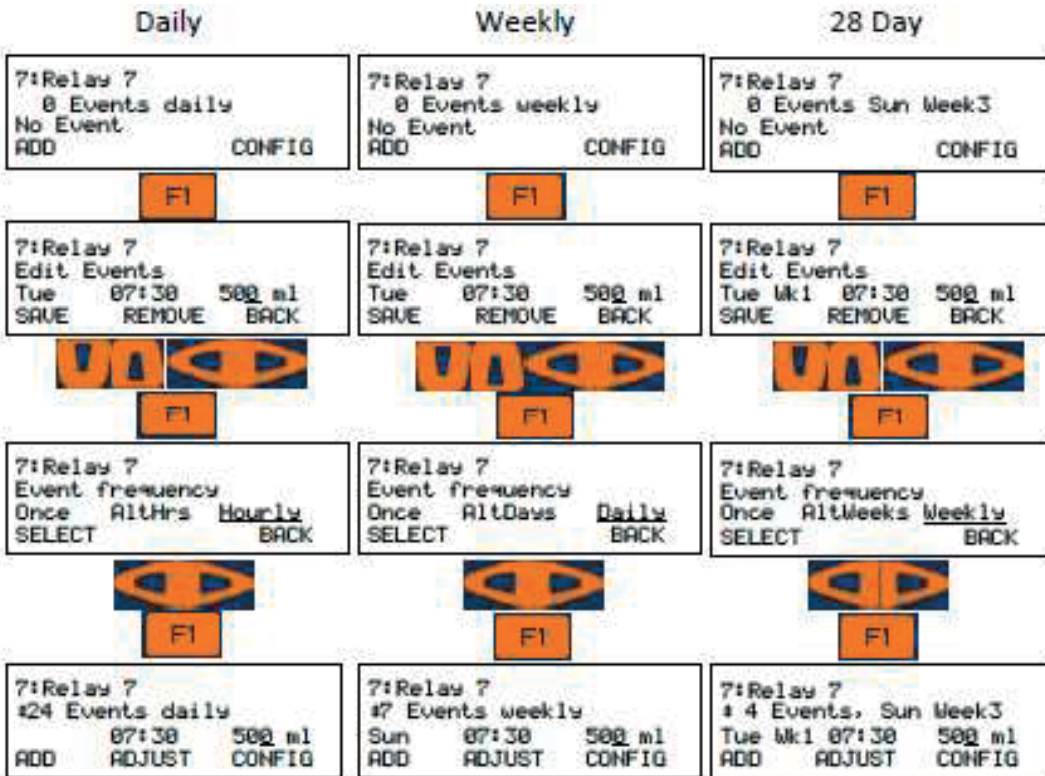

In the example below, we chose the maximum entry for each cycle. The Daily selection of Hourly will mean the pump will feed 24 times every day. Look for the underlined word.

The Weekly cycle will feed every day and the 28 Day cycle every week.

3. The event has been created. Press F1, **Add** to create another event, F2, **Adjust** to make changes to the current events or F3, **Config** to make changes to the cycle, Prebleed, etc. See 10.6 and 10.6.7 for Configuration choices.

Pulse relays use a similar menu.

Finish the programming. Use 10.4 Naming the Output, 10.8 Interlocks and, 10.9 Blocks, or 10.7.2 Remove or Edit an Event

If you have just added event(s) from the previous programming chart, press F2, Adjust to edit the entries or delete them. If you were not in this menu, follow these steps;

- 1- Press Menu and scroll down to Biotiming, Events and press OK.
- 2- Scroll down to your relay and press OK
- 3- Use the up and down arrows to find an event you wish to edit or delete.

- 4- Press F2, **Adjust** to edit or delete an event or F3, **Config** to re-configure the relay. See 10.7 Configuring an Event-Other Relay
- 5- If you pressed Adjust, use the arrows to make changes to the start time and length. Press F1 to save and exit.

This process works for all relays.

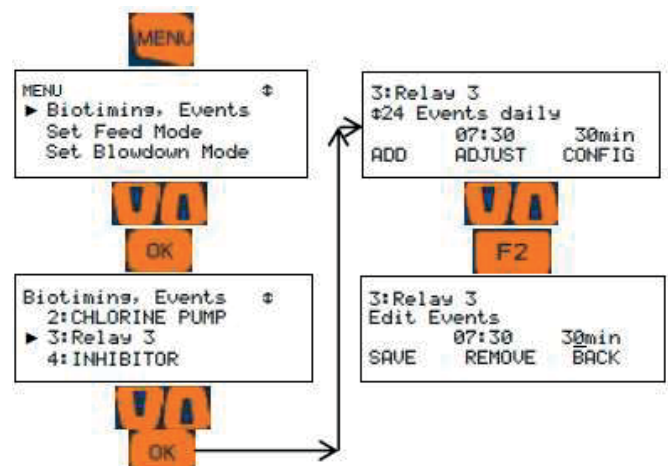

## Programming the Outputs

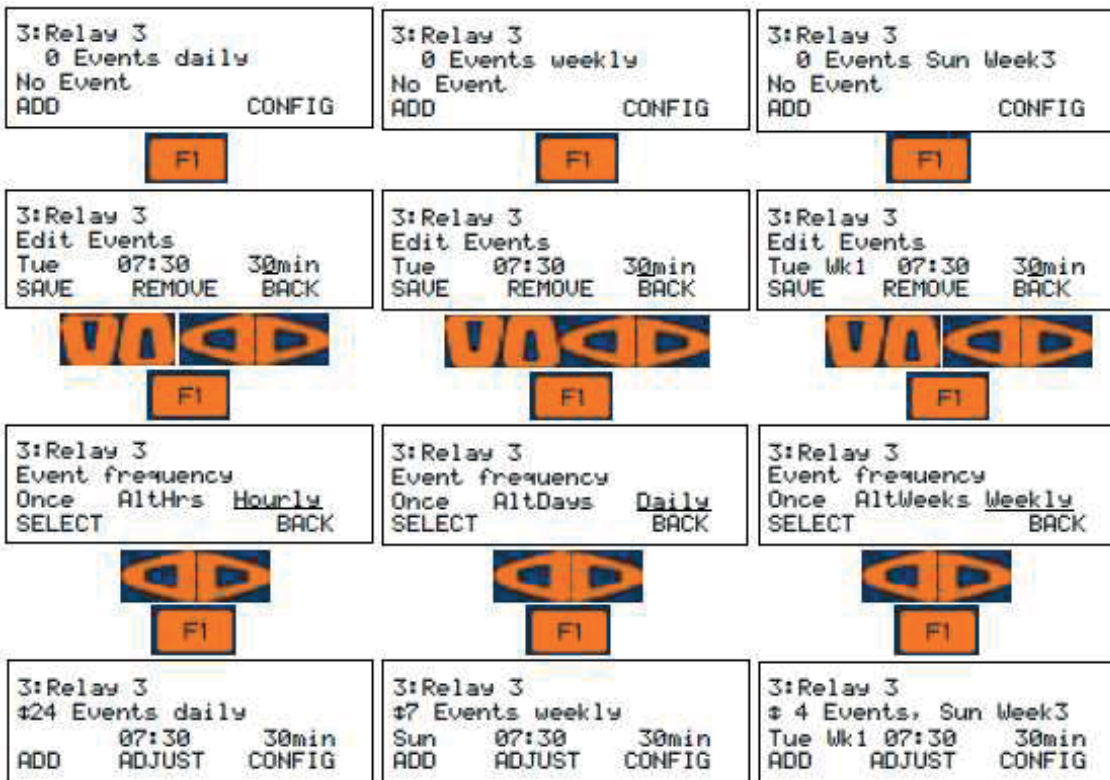

### 10.8 Interlocks

Interlocks are digital inputs that temporarily pause an output from operating (Relays 1 to 9 and 4-20mA outputs). Typically, a cooling tower control program will include a digital input signal from a flow switch. When the flow switch indicates that no sample water is flowing, any relay that has this digital input listed as an interlock will stop operating until the flow is restored.

Boilers can use 'online' relay dry contact signals to enable which boilers can be bled or have chemicals fed to them.

#### 10.8.1 Setting/Removing Interlocks

- 1- From the MENU page, scroll down to I/O Setup and press OK
- 2- Scroll down to the relay you wish to edit and press OK
- 3- Scroll down to 'Interlock' and press OK
- 4- Scroll up and down to see all available interlocks (digital inputs configured as Contact Set) Press **F1** to select.
- 5- The block  symbol indicates that this input is currently selected.

From this screen, you can choose multiple interlocks or remove them. Once an interlock is chosen, the **F1** key will remove it.

Notice the F2 key says 'OR'. This means if any one of the interlocks are 'ON', (shorted) the relay will be paused. If you press F2, the 'OR' will change to 'AND'. AND means all interlocks chosen must be ON to produce the pause. Multiple Interlocks are not typical.

Any one interlock can be used on multiple relays and 4-20mA outputs. Typically, all outputs on a cooling tower are paused by the flow switch input.

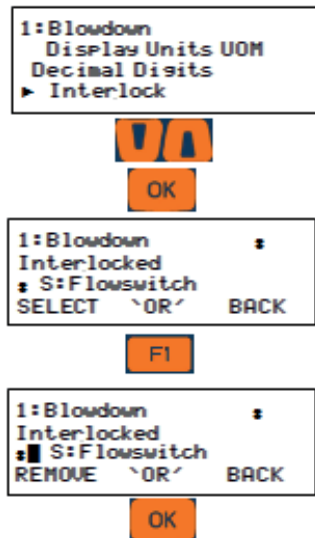

- 1- Press the MENU key
- 2- Use the ARROW keys to select I/O Setup, then press OK
- 3- Use the ARROW keys to select 1: Blowdown, then press OK
- 4- Use the ARROW keys to select 'Blocked by' then press OK
- 5- Choose an output with ARROW keys and press SELECT [F1]. A solid square ■ will appear to the left of any and all output(s) selected. Press F1 REMOVE to deselect an output. Once the blocking output selections are correct, press OK to save your selections.

## 10.9 Blocks

Blocks are used to ensure that two or more relays (Relays 1 to 9) are not on together should they be incompatible or cause problems. Often, chemical pumps will be blocked by the blowdown valve to prevent chemical feeding going down the drain.

### Setting blocks – all relays 1 to 9.

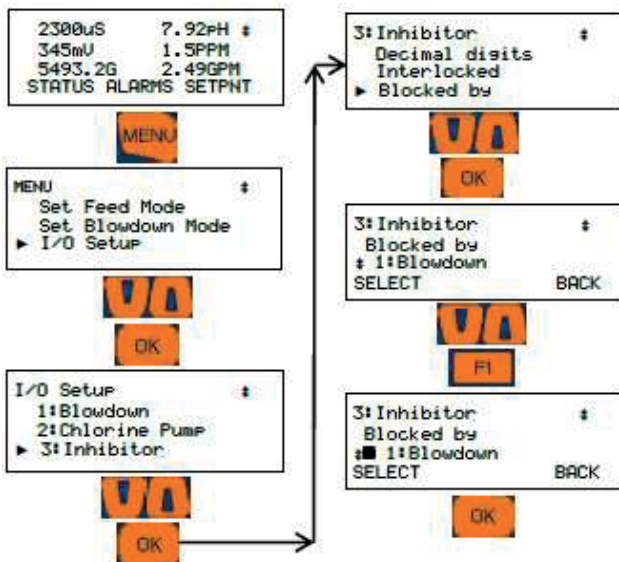

## 10.10 Control Action (ON Decreases/ON Increases Sensor):

**Note:** Used for R1-R5, and P6-P9 in the ON/OFF mode.

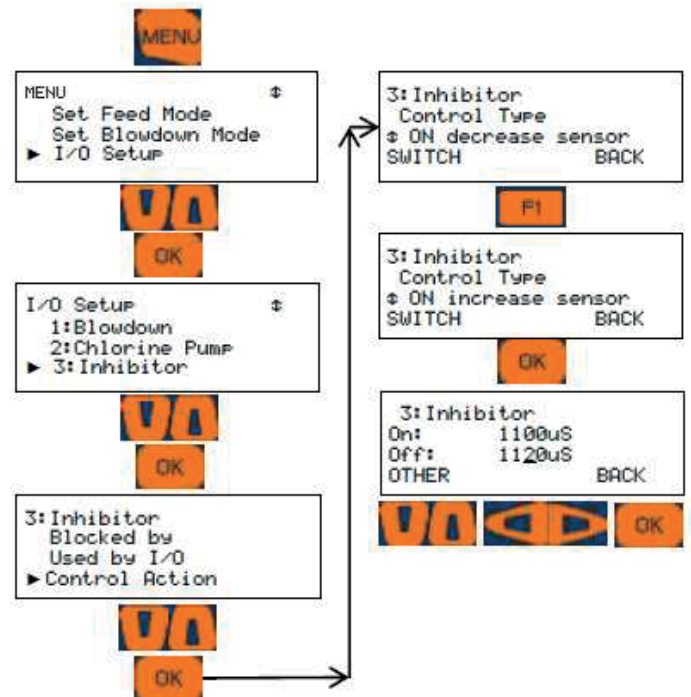

Control Action tells the controller what direction to expect the sensor value to take if the relay is turned on. Since Acid will drive a pH downward, this would be set for 'ON Decreases'. Most chemicals drive the sensor upwards. That would be an 'ON Increases' setting. The Control Action choice allows the output control to be inverted. This could be useful if the only blowdown valve available is a normally open solenoid, or if other controls require the inverted

## Programming the Outputs

control signal. If you need to switch from acid to caustic on a pH control application or feed inhibitor based on conductivity, you can reverse control using these steps.

- 1- Press MENU
- 2- Scroll to the I/O Setup selection and press OK
- 3- Scroll to select the relay desired and press OK
- 4- Scroll to Control Action and press OK  
Screen shows "ON decreases sensor" which is normal for blowdown function as the conductivity should decrease when the blowdown valve is open.
- 5- To invert the output to "ON increases sensor" press the SWITCH [F1] key, then press OK.

Since the basic control has changed, the display changes to the relay Adjust Set-points screen to allow you to edit the new set-points. You will notice that the On: and Off: values have been reversed.

- 6- Use the ARROW and OTHER keys to change the limit points if needed, then press OK to accept and use these values.

### 10.11 Special Control Functions:

Special controls are additional types of control that improve on simple ON/OFF control. The three general control modes have the following special controls;

**Feed Control Types:** Time Cycling, Time Modulate, and Proportional, Integral and Derivative (PID) control.

**Blowdown control Types:** Captured Sample, Varying Cycles.

**Events-Other control Types:** Prebleed Lockout, Alarm output, Sensor wash



#### SPECIAL CONTROL TIP:

When using Timed Cycling, Time Modulate or PID control, best results for tuning the loop are achieved if you only change one variable at a time and wait for two or three cycles to observe the effect of this change. This would include changing the stroke % of the pump and any setting in the special control program.

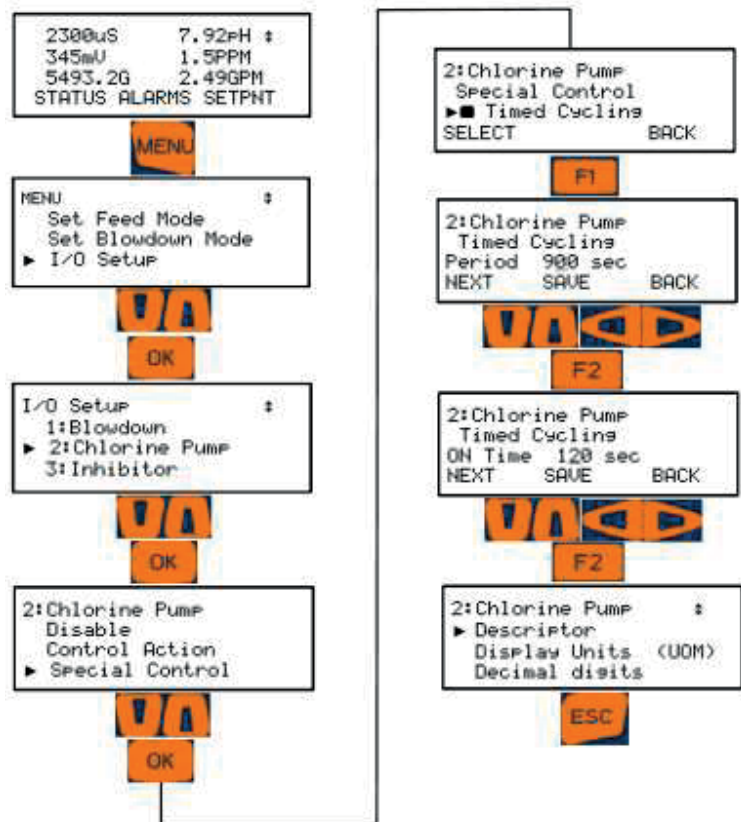

## 10.11.1 Timed Cycling:

Note: Special Control for Feed type relay. These instructions work with relays 1 – 5. These instructions work with relays 6 – 9 when they are in ON/OFF mode.

Often there is a long time delay between adding a chemical and measuring its effect at a sensor. This causes set-point overshoot and poor control.

**Examples:** Pumping acid into a large process tank or adding bleach to a cooling system with a large sump volume.

**Timed Cycling** feeds for a user defined **ON Time** then waits for a user defined time before feeding again, allowing the system to respond to the fed chemical. During the **ON Time**, ON-OFF pumps and frequency controlled pumps feed on set-point control.

The **On Time** and **Period** are adjustable. The Off Time is the difference between the two.

If the **Period** is 50 seconds and the **On Time** is 10 seconds, the Off Time will be 40 seconds.

The '**Chemical 123**' Diagnostic display counts down the time in the **ON Time** and **OFF Period**.

Selecting a **Special Control** automatically sets typical default times or sensor values.

Adjust the default values for your site's application.

1. To Set and adjust the Timed Cycling press MENU
2. Scroll to the I/O Setup selection and press OK
3. Scroll to select the desired relay (2:Chlorine Pump) and press OK
4. Scroll to Special Control and press OK
5. Scroll to Timed Cycling and press F1
6. Use Up/Down and Left/Right Arrow keys to Edit the Period value then press F2. In this example the default **900 second Period**.
7. Use Up/Down and Left/Right Arrow keys to Edit the ON Time then press F2. In this example the default is **120 second ON Time**.
8. Relay 2 is now ON for 120 seconds and OFF for 780 seconds in each 900 second Period.
9. Press ESC Escape to save and exit.



### SPECIAL CONTROL TIP:

When using Timed Cycling, Time Modulate or PID control, best results for tuning the loop are achieved if you only change one variable at a time and wait for two or three cycles to observe the effect of this change. This would include changing the stroke % of the pump and any setting in the special control program.

## 10.11.2 Time Modulate

**Note1:** Time Modulate is a Special Controls selection for Feed type relay

**Note2: Relays P6-P9 must be set to ON/OFF Mode**

Time modulate has adjustable turn on and turn off set-points, a period and a direction, Increasing or Decreasing the variable. Example of Increasing: A chlorine pump will increase the ORP reading. Example of Decreasing: A blowdown valve will decrease conductivity.

When using Time Modulate on an increasing control loop, the Turn On set-point will be lower than the Turn Off set-point. When the ORP is below the Turn On set-point, the output relay is on constantly. When ORP is above the Turn Off set-point, the output relay is off constantly. In either case, Time Modulate is not operating until the ORP is between the set-points. It is on in proportion to the ORP value with respect to the range between the set-points.

**Example: Period=100** seconds, ORP **Turn ON** set-point = 400mV and ORP **Turn OFF set-point** = 500mV, current ORP = 450mV. 450mV is half way between 400 and 500 so the pump will be on for 50% of the period time or in this example 100 x 50% = 50 seconds and off for 50% or 50 seconds.

If the ORP drops to 430, the pump will be on for 70% and off for 30% of the 100 second period.

**Time Modulate** works for both increasing and decreasing control loops.

1. To Set and adjust the Time Modulate press MENU
2. Scroll to the I/O Setup selection and press OK
3. Scroll to select the desired relay (2:Chlorine

## Programming the Outputs

- Pump) and press OK
4. Scroll to Special Control and press OK
5. Scroll to Time Modulate and press F1
6. Use Up/Down and Left/Right Arrow keys to Edit the Period value then press F2 in this example the default Period is set to **120 second**
7. Use ESC key to Exit

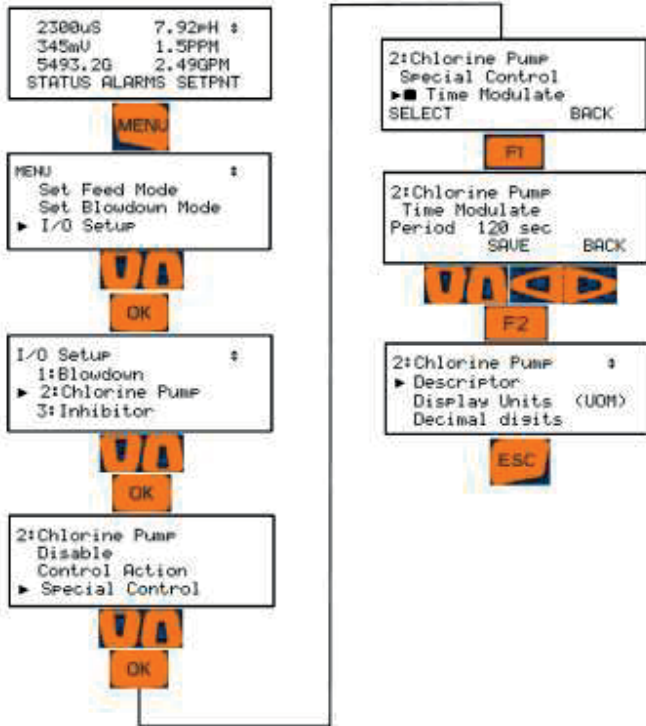

control. PID control can also be used on 4-20mA outputs.

We highly recommend Timed Cycling or Time Modulate for control over PID because these methods are highly functional and simple to set up/understand. In most water treating applications, a full PID setup does not noticeably increase the control regulation of the process but is difficult to set up/tune. However, using only the proportional setting of the PID setup and leaving the others settings at default is easy and effective.

If Relay outputs 1 to 5 are configured for PID control, they are implemented by continuously modifying the pump relay ON & OFF times.

1. To set and adjust the PID settings, press MENU
2. Scroll to the I/O Setup selection and press OK
3. Scroll to select the desired output (6:Chlorine Pump) and press OK
4. Scroll to Special Control and press OK
5. Scroll to PID Control and press F1
6. Use Up/Down and Left/Right Arrow keys to Edit Kp Proportional value then press F2
7. Use Up/Down and Left/Right Arrow keys to Edit Integral Rate value then press F2
8. Use Up/Down and Left/Right Arrow keys to Edit Difference Rate value then press F2
9. Use Up/Down and Left/Right Arrow keys to Edit Relay Period value (if P6-P9 is set to pulse output skip this step) then press F2
10. Use ESC key to Exit

This method works on relays 1 – 5 and with 6 – 9 when they are in the ON/OFF mode.

### 10.11.3 PID Control



#### SPECIAL CONTROL TIP:

When using Timed Cycling, Time Modulate or PID control, best results for tuning the loop are achieved if you only change one variable at a time and wait for two or three cycles to observe the effect of this change. This would include changing the stroke % of the pump and any setting in the special control program.

Parameter	Minimum	Maximum	Default	Notes
Kp Proportional	0.001	10	0.5	
Integral Rate	0	9999	30	0 = no Integral update
Difference Rate	0	999	15	0 = no Differential update
Relay Period	30	600	120	In seconds

Table 14 PID parameters

#### Note: Relays P6-P9 must be set to ON/OFF Mode

See section 10.3 Enable and Configure a Relay

Each of the P6 to P9 and R1-R5 Outputs can be configured for PID (Proportional-Integral-Difference)

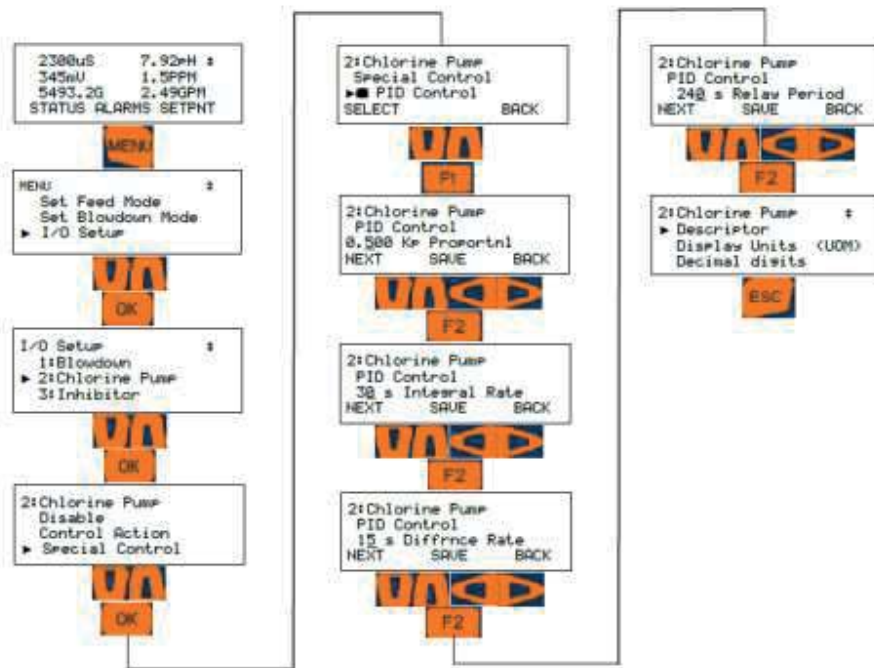

The 2-wire conductivity sensor used in the Captured Sample method is not thermally compensated since by design, boilers maintain a reasonable constant temperature and pressure. Therefore, the Measure sequence requires a reading from a steady temperature sensor. Flashing is disruptive to this method, so plumbing is critical to a proper reading.

Refer to Figure 62

A sample from the skimmer in the drum is passed by the sensor, a motorized valve or solenoid, then MOST

### 10.12 Boiler Blowdown:

Blowdown valves and solenoids typically require 120VAC or line voltage. **Relays 6-9 are not covered in this manual for the purpose of boiler blowdown.**

#### 10.12.1 Continuous Boiler Blowdown

Continuous Boiler blowdown is common on larger, high pressure boilers and routes a continuous low flow stream through a sample cooler upstream of the thermally compensated conductivity sensor. (4-wire probe) The blowdown valve is installed on a parallel line to the flash tank.

Blowdown control is configured like a cooling tower bleed and is therefore not detailed in this section of the manual. See 10.5 Configuring a Blowdown Relay

#### 10.12.2 Captured Sample Blowdown

Captured Sample is the preferred method for smaller and medium sized boilers because it does not require a continuous sample, sample cooler or cooling water supply. A continuous sample on a small boiler would drop the conductivity too quickly. Controlling the conductivity level would be extremely difficult, wasting water that has been treated with chemicals, filtered and heated.

IMPORTANTLY, a needle valve or small orifice. The object of the restriction is to ensure that the flashing, (high pressure, high temperature water ‘flashes’ when subjected to a much lower pressure) is limited to a point after the motorized valve. The restriction divides the high and low pressure whereby the flashing takes place after the restriction, not near the sensor. In this way, the electronic valve operates in a constant bath of liquid with no air or gas present. Air bubbles are the number 1 reason for failure to correctly read the boiler conductivity!

Therefore, be certain that all valves upstream of the sensor are 100% open and restrictions minimized. Flashing must be limited to the needle valve.

**The sample routine** has 4 steps; Sample, Measure, Blowdown, and Resample.

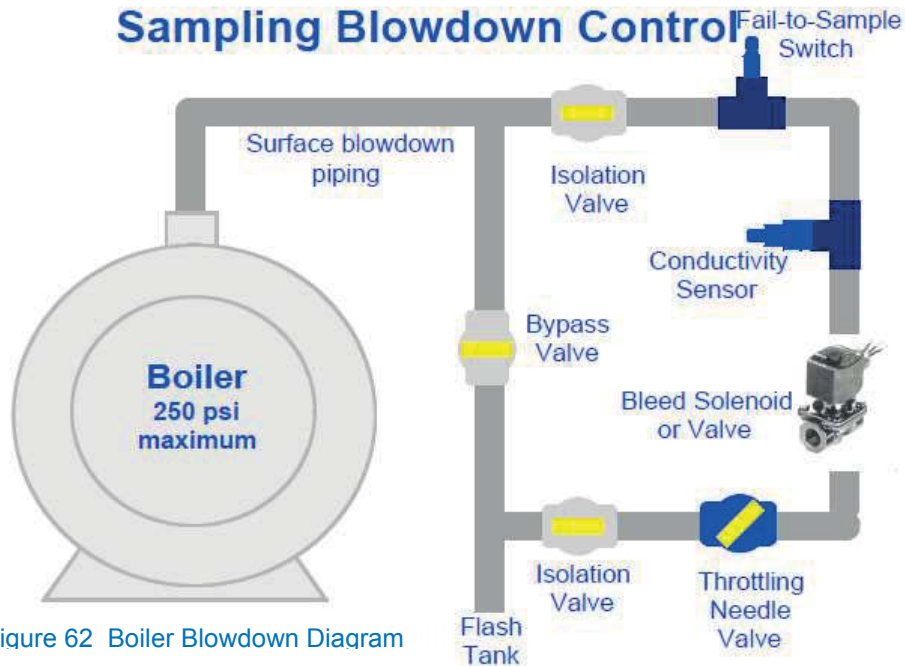

Figure 62 Boiler Blowdown Diagram

The Sample time should be set for a long enough period that ensures a fresh sample has passed the sensor.

The Measure time is 60 seconds. This cool down period increases accuracy of the reading as well as adding to the life of the probe. Typically, this value is not adjusted.

Blowdown defaults to 120 seconds, a good starting point.

Resample is the wait time between sample cycles.

After the resample time has elapsed, the valve opens and takes a new sample to start over.

Basic operation:

At the start of a captured sample routine, the blowdown valve opens for the **Sample** period. The pipe at the sensor should be hot before the valve closes.

The **Measure** stage holds the valve closed for 1 minute to cool the sample and get a steady reading. The controller uses the sensor value at the end of the measure period. This sensor reading is converted to a conductivity value and compared with the set-points. If too high, a blowdown step is started. If below the turn off set-point, the blowdown step is skipped.

The **Blowdown** valve is now opened for the set time and closed. A second measure time is started, allowing the sample to cool as before, read the sensor and compare it to the set-points. As long as it is above the turn off point, the controller will oscillate between the measure and blowdown steps.

Once the conductivity low level is reached, the **Resample** timer holds the valve closed until the next cycle starts.

NOTICE:

If the routine is not keeping the boiler conductivity within the preferred range, consider these adjustments;

Conductivity rises: 1) If the conductivity rises too much between samples, decrease the resample delay time (Run the routine more often).

2) If the measure/blowdown steps are repeating without stop, lengthen the blowdown time or open the restriction to allow more flow.

Remember, opening the restriction moves you closer to losing control of the flashing. Adjust in small amounts and monitor 2 or 3 cycles before approving the change.



Pay close attention to the plumbing layout in Figure 35. The direction of the pipes is not as important as having the flashing controlled beyond the sensor and blowdown valve!

**Captured Sample is not recommended for Pulse relays 6 – 9.**

Choosing the captured sample routine and setting the timers;

- 1- Press MENU
- 2- Scroll down to I/O Setup and press OK
- 3- Scroll down to your blowdown valve and press OK
- 4- Scroll down to Special Control and press OK
- 5- Scroll down to Captured Sample and press F1 SELECT.
- 6- Use the arrows to adjust the value if necessary then press F2 Save when done.
- 7- Adjust the Measure, blowdown and resample values as needed. Press F2 Save to continue.

The Fail to Sample option is not currently implemented.

The routine is set. Continue to use this menu to edit the relay name, engineering units, decimal digits, interlocks and blocks.

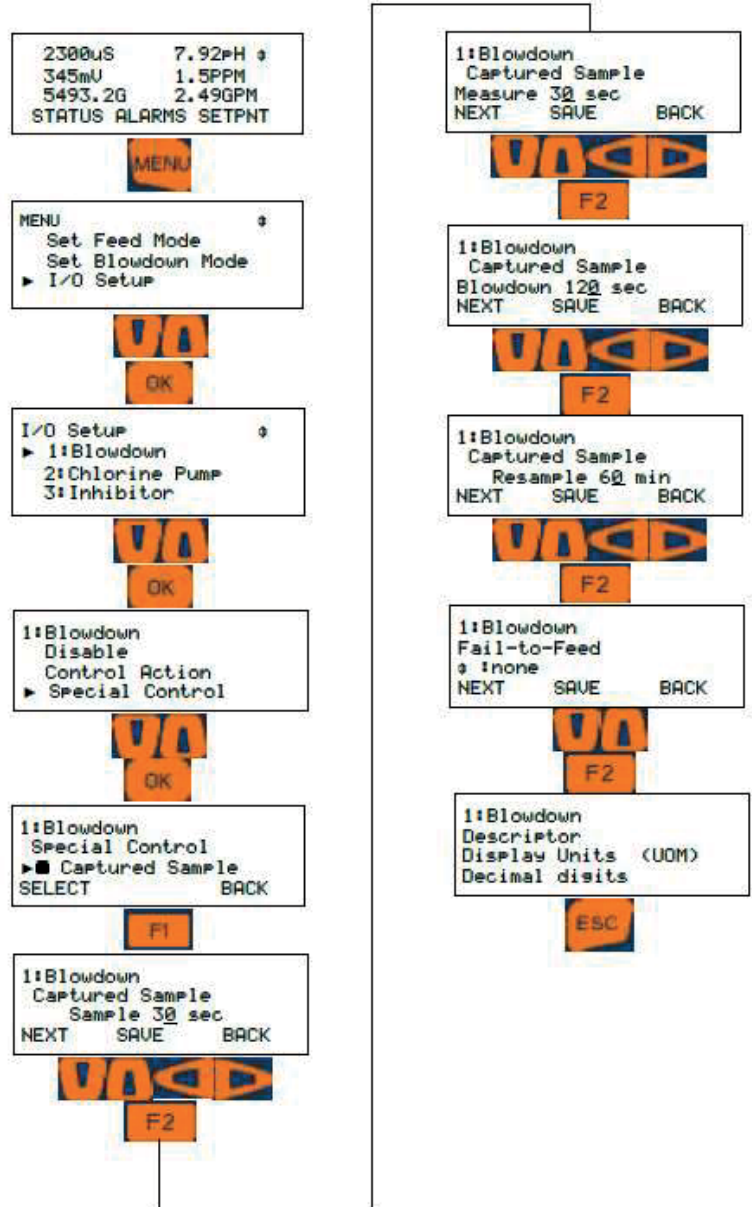

# Programming the Outputs

## 10.12.3 Varying Cycles:

Varying Cycles is not recommended for Pulse relays 6 – 9.

Note: WHEN “CONTROL Type” is set To Blowdown

Controls tower bleed on the ratio of the Tower to Make-up conductivity.

The user selects the cycles of concentration for three ranges of make-up conductivity and maximum tower sump conductivity.

The controller measures the make-up conductivity and controls bleed @ one of the three cycles of concentration. If the tower sump exceeds the maximum conductivity, the tower conductivity is used to control the bleed & to reduce the sump conductivity.

Where Used:

If your make-up changes seasonally or periodically and you have a 2nd conductivity sensor installed in the tower make-up line you can control using Varying Cycles.

Where Not Used:

1. If the holding time or turnover time of the tower is 'long' then the bulk of the tower water has not changed when the make-up conductivity changes & you may scale if hardness limited.

*'Long' is site specific and a function of temperature, water chemistry and treatment program.*

2. If the make-up conductivity does not track the component that limits the maximum cycles. For example, hardness may increase with conductivity but silica may not & you may be silica limited.

Varying Cycles Setup:

- 1- To Set and adjust the Varying Cycle press MENU
- 2- Scroll to the I/O Setup selection and press OK
- 3- Scroll to select the desired relay (1:Blowdown) and press OK
- 4- Scroll to Special Control and press OK
- 5- Scroll to Varying Cycle and press F1
- 6- Use Up/Down and Left/Right Arrow keys to Edit the max conductivity value then press F2 in this example If the tower sump exceeds **Max**

**Conduct, 3000 uS**, the bleed opens to limit the conductivity.

- 7- Use Up/Down and Left/Right Arrow keys to Edit the High Cycles value then press F2 in this example **High Cycles = 2.5** so the tower sump would be nominally 2500 uS ( 1000 x 2.5).
- 8- Use Up/Down and Left/Right Arrow keys to Edit the High Range value then press F2 When the make-up conductivity less than **High Range**, in this example **1000 uS**, the bleed controls @ **High Cycles**
- 9- Use Up/Down and Left/Right Arrow keys to Edit the Med Cycles value then press F2 in this example **Med. Cycles = 4.25** so the tower sump would be nominally 2762.5 uS ( 650 x 4.25).
- 10- Use Up/Down and Left/Right Arrow keys to Edit the Med Range value then press F2 When the

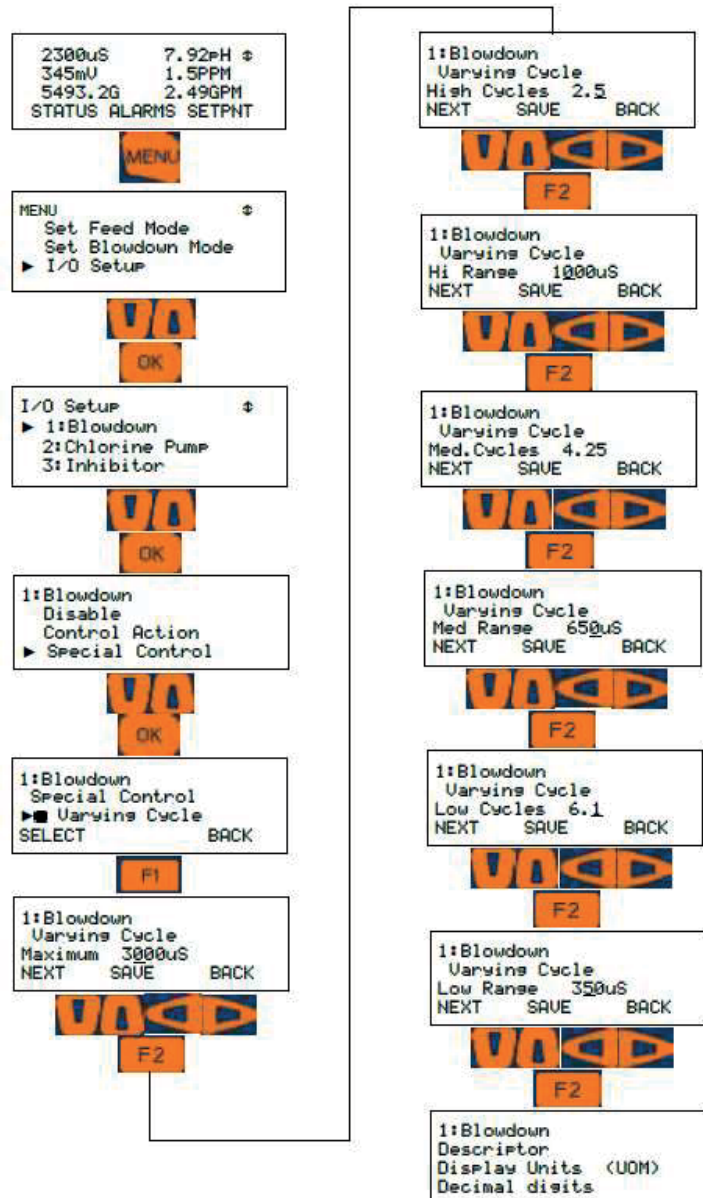

make-up conductivity less than **Medium Range**, in this example **650 uS**, the bleed controls @ **Med. Cycles**

- 11- Use Up/Down and Left/Right Arrow keys to Edit the Low Cycles value then press F2 in this example **Low Cycles = 6.1** so the tower sump would be nominally 2135 uS ( 350 x 6.1)
- 12- Use Up/Down and Left/Right Arrow keys to Edit the Low Range value then press F2 When the make-up conductivity less than **Low Range**, in this example **350 uS**, the bleed controls @ **Low Cycles**

## 10.13 How to Setup a Relay as an Alarm Output:

An Alarm relay will change states whenever the controller post an alarm condition on the alarm page.

This method applies to all 9 outputs, however, when enabling a pulse output, relays 6 – 9, choose the ON/OFF setting. See section [9.2 Enable and Configure a Relay](#).

**Note:** R1-R5 relays are Form C (SPDT) and if using NC contact for Alarm, NC contact is not held closed so losing power won't open the contact.

R6-R9 relays are optoMOS. They can be used with 24VDC/250mA power. They must be in the ON/OFF mode.

- 1- To Set a Relay to an Alarm press **MENU**
- 2- Use Up/Down Arrows to navigate to **I/O Setup**
- 3- Scroll to select the desired relay (for example 5:unused) and press **OK**, if there is no selection (Empty list) it means you haven't set any relays as an Event-Other
- 4- Use Up/Down Arrow keys to select **Special Control** then Press **OK**
- 5- Use Up/Down Arrow keys to Scroll to **Alarm Output** Press **F1**
- 6- Use **ESC** key to Exit

Note: See [9.2 Naming an Input or Output](#) to rename the relay for example to General Alarm

## 10.14 Prime (Force On) a Relay

All relays can be forced on temporarily if not disabled, blocked or interlocked. If disabled, see [10.3 Enable and Configure a Relay](#). If blocked, see [10.9 Blocks](#). If Interlocked, see [10.8 Interlocks](#).

To force any relay on, press Menu.

Scroll down to Prime, Force ON and press OK. Scroll down to the relay of your choice and press OK.

The timer defaults to 5 minutes. Use the arrows to adjust as needed. The underline is the cursor.

Press F3 Start

If you wish to stop the relay prior to the timer ending, press F3 Cancel.

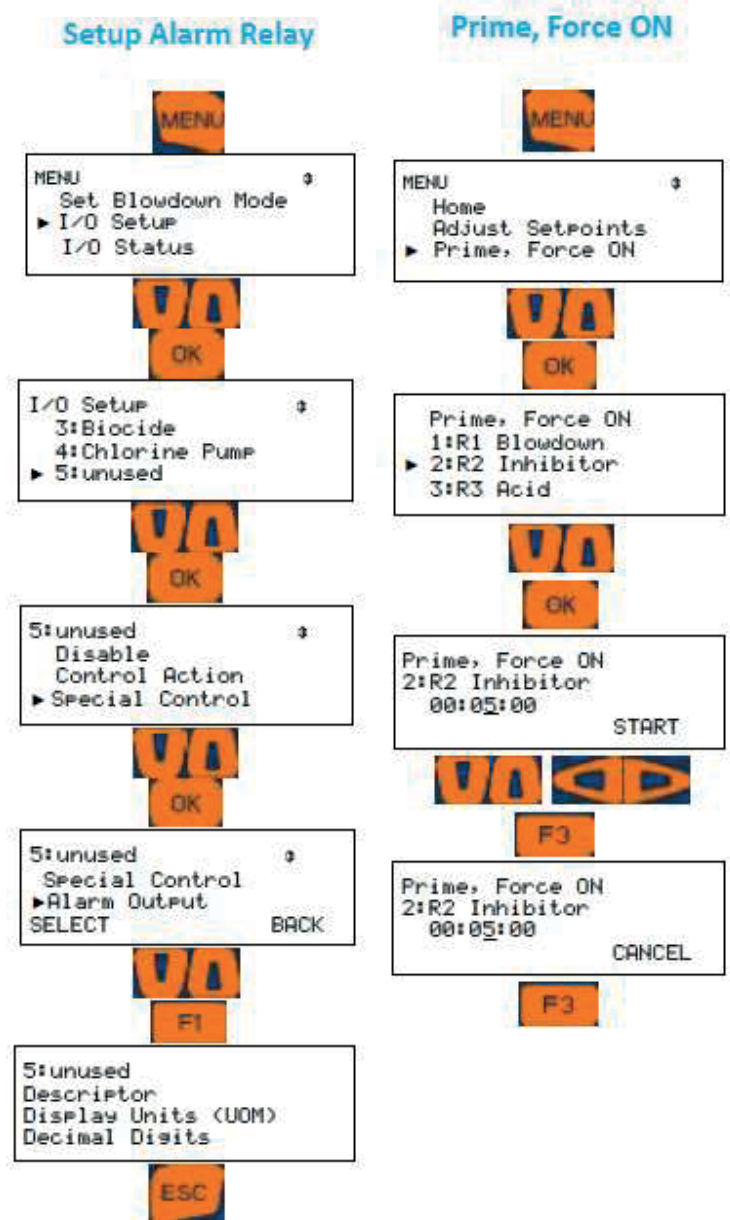

## 10.15 Sensor Wash:

### Future Item

A special control function that allow pH and ORP sensors in the probe header to be washed inline with acid based solution on a timer. **R6-R9 must be in ON/OFF mode.**

The relay will halt acid and oxidant outputs for a predetermined time to allow the sensors to recover from the acid wash.

## Programming the Outputs

### 10.16 4-20mA outputs:

4-20mA Outputs display both the loop current and it's corresponding 0-100%.

**Manual** = User sets current. **Auto** = Sensor controls current.

Displays the present **0%** to **100%** output set-point.

Manual Mode:

Use **Manual mode** to verify the 100% ON=20mA, OFF=4mA or modulate operation of the proportional pump or valve that the 4-20mA output is controlling. Use **Manual mode** to verify the monitoring input that is using the current loop value to represent a controller conductivity, pH, ORP or corrosion rate sensor or ppm calculation.

Load Powered 4-20mA Loop:

4-20mA current outputs are isolated and loop powered (24VDC).

Open Loop Alarm:

The DC isolated 4-20mA output alarms on an open loop, this function could be turn ON/OFF

Calculating Loop Current:

4-20mA Output current (mA) = 4 + 16 x ( Sensor Value / ( **20mA Set-point** – **4mA Set-point** ) ) Use the absolute value of the set-point difference for **20mA Set-point < 4mA Set-point**.

For example:

$$15.42\text{mA} = 4 + 16 ( 1785 / ( 2500 - 0) )$$

The output card can be configured to drop to 4mA when the stop button is pressed on the keypad (when using to control a pump or solenoid) or to continue if used to send sensor value to DCS.

#### 10.16.1 How to assign 4-20mA output to control decrease (e.g Acid Feed):

- 1- To Set 4-20mA output to control decrease press **MENU**
- 2- Use Up/Down Arrows to navigate to **I/O Setup**
- 3- Scroll to select the desired output (for example E:4-20mA output) and press **OK** and then press **F2**
- 4- Use Up/Down Arrow keys to select desired input (here we selected pH input) then press **F1**
- 5- The next menu will ask for interlock if any needed. If no need, scroll to none then Press **F1** (you could interlock it with any digital input for example flow switch or a phantom DI)
- 6- Set the high pH value then press **F1**(in this example if pH sensor is reading 7.7pH the 4-20mA will be 20mA and the acid pump will be feeding at max speed)

- 7- Set the low pH value, then press **F1**(in this example if pH sensor is reading 7.20 pH, the 4-20mA will be 4.0mA and the acid pump should stop feeding).
- 8- In this example between pH 7.20=4.0mA and 7.70=20mA the 4-20mA output will be proportional
- 9- Press **ESC** Escape to finish or press **F1** to continue with output setup. You can choose to turn the open loop alarm on or off, then choose to set the output to drop to 0% (4mA) or remain as is when the keypad **STOP** button is pressed. This allows you to shut down the output to a pump, or continue to send a value to a DCS.

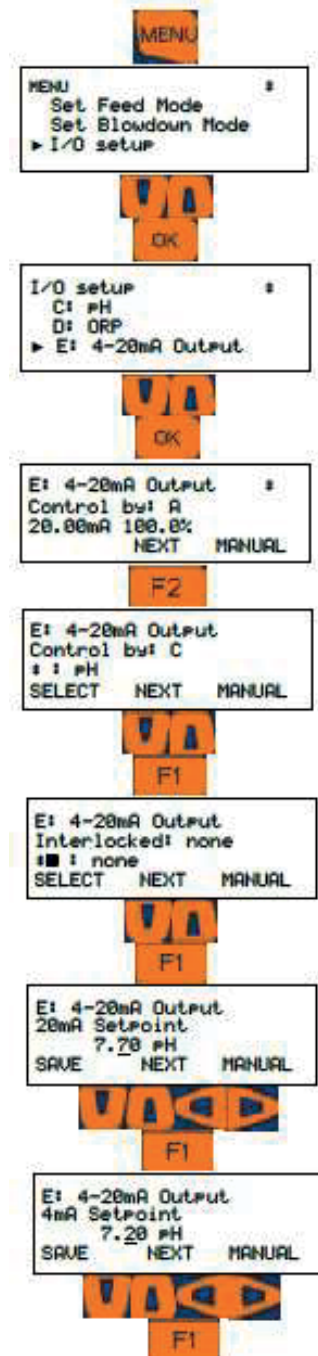

### 10.16.2 How to assign 4-20mA output to control increase (e.g Caustic Feed):

- 1- To Set 4-20mA output to control increase press **MENU**
- 2- Use Up/Down Arrows to navigate to **I/O Setup**
- 3- Scroll to select the desired output (for example E:4-20mA output) and press **OK** and then press F2
- 4- Use Up/Down Arrow keys to select desired input (here we selected pH input) then press F1
- 5- The next menu will ask for interlock if any needed if no need scroll to none then Press F1 (you could interlock it with any digital input for example flow switch or phantom DI)
- 6- Set the low pH value then press F1(in this example if pH sensor is reading 7.00 pH the 4-20mA will be 20mA and the Caustic pump will be feeding at max speed)
- 7- Set the high pH value then press F1(in this example if the pH sensor is reading 7.50pH, the output will be 4.0mA and the pump should stop)
- 8- In this example between pH 7.00=20mA and 7.50=4.0mA the 4-20mA output will be proportional
- 9- Press Escape to finish or press F1 to continue with output setup. You can choose to turn the open loop alarm on or off, then choose to set the output to drop to 0% (4mA) or remain as is when the keypad Stop button is pressed. This allows you to shut down the output to a pump, or continue to send a value to a DCS.

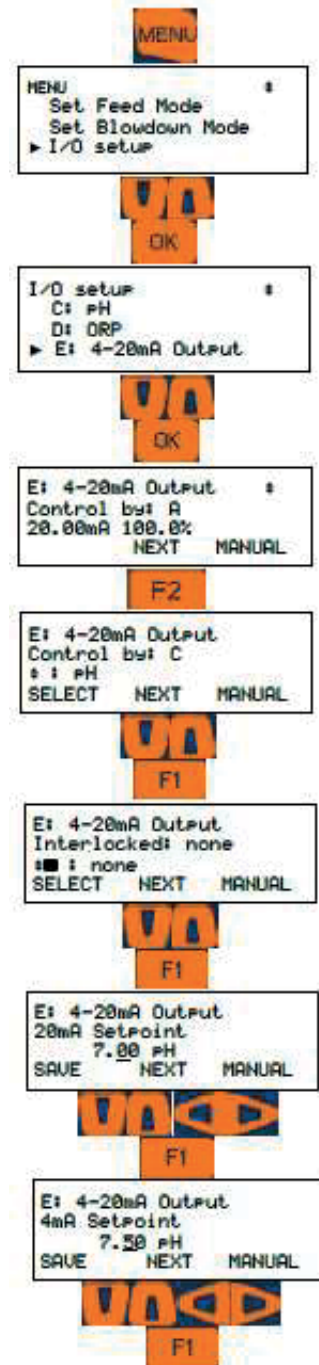

### 10.16.3 How to assign 4-20mA output to measured value (application: feedback to PLC/DCS):

- 1- To Set 4-20mA output to measured value press **MENU**
- 2- Use Up/Down Arrows to navigate to **I/O Setup**
- 3- Scroll to select the desired output (for example E:4-20mA output) and press **OK** and then press F2
- 4- Use Up/Down Arrow keys to select desired input (here we selected pH input) then press F1
- 5- The next menu will ask for interlock if any needed if no need scroll to none then Press F1 (you could interlock it with any digital input for example flow switch or phantom DI)
- 6- Set the High pH value then press F1(in this example if pH sensor is reading 14.00 pH the 4-20mA will be 20mA)

- 7- Set the Low pH value then press F1(in this example if pH sensor is reading 0.00 pH the 4-20mA will be 4.0mA)
- 8- In this example between pH 14.00=20mA and 0.00=4.0mA the 4-20mA output will be proportional.
- 9- Note: The customer must use the same scale. If their scale is different, one side must change to equal the other.
- 10- Press Escape to finish or press F1 to continue with output setup. You can choose to turn the open loop alarm on or off, then

## Programming the Outputs

choose to set the output to drop to 0% (4mA) or remain as is when the keypad Stop button is pressed. This allows you to shut down the output to a pump, or continue to send a value to a DCS.

### 10.16.4 How to set 4-20mA output to Manual Mode:

- 1- To Set 4-20mA output to Manual press **MENU**
- 2- Use Up/Down Arrows to navigate to **I/O Setup**
- 3- Scroll to select the desire 4-20mA output (for example E:4-20mA output) and press **OK** and then press F3 to set it to Manual
- 4- Use Up/Down and Right/Left Arrow keys to set the desire percentage (0-100% is 4-20mA), press F1 and then F2
- 5- Press F2 to go to next display since we are not controlling the output with any type of sensor in Manual Mode
- 6- If any interlocked needed use UP/Down arrow keys to select one of the digital or phantom inputs then press F1 and then F2 to go to next display
- 7- If any open loop alarm needed (if the 4-20mA output doesn't see a closed loop you will get open loop alarm) use F3 to switch back and forth between ON and OFF and F1 to save changes
- 8- Use **ESC** key to Exit

### 10.16.5 Linking a 4-20mA Input with a 4-20mA Output

Any analog input from A to N, including phantom inputs in this range, can be used to control a 4-20mA output. Use the same steps as above and choose that input letter.

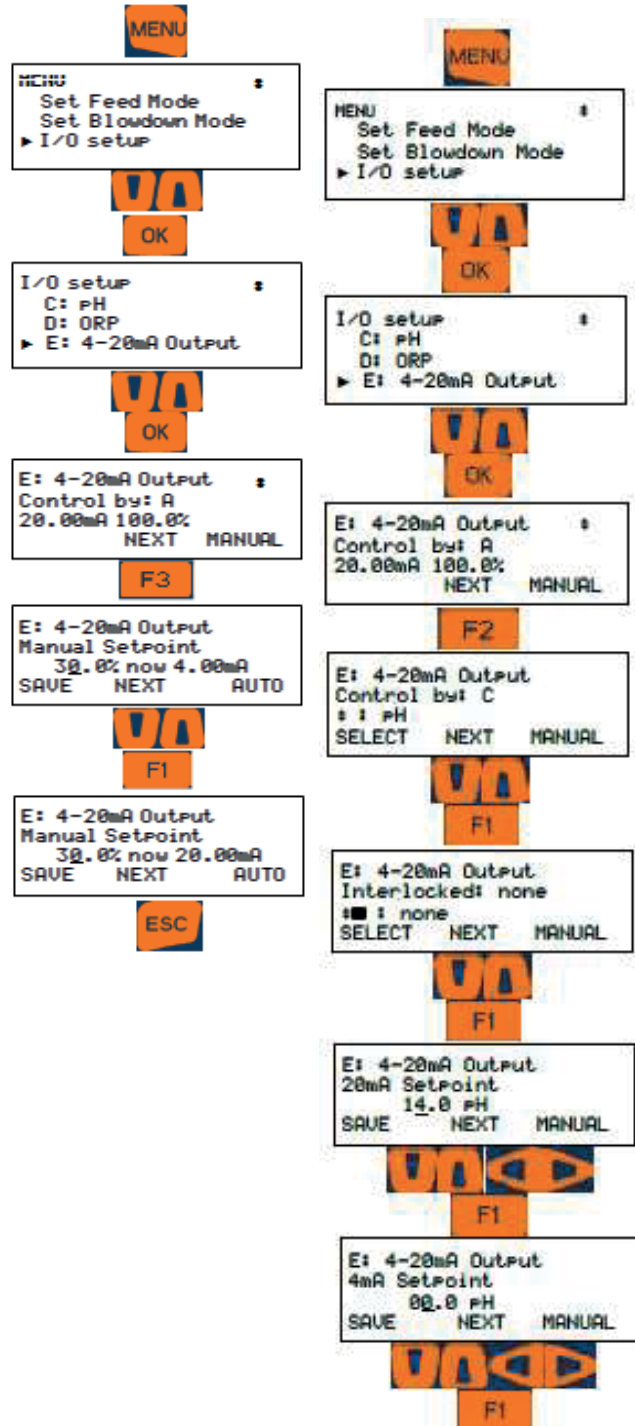

10.16.6 Calibration of a 4-20mA Output

To calibrate 4-20mA output you will need a Multimeter set in mA mode placed in series with the output card and a load. See **Figure 36**

- 1- From the HOME display, press the CAL key
- 2- Using the UP and DOWN ARROW keys choose the 4-20mA Output you would like to calibrate, then press OK.
- 3- Observe the reading on your mA meter that is in series within your circuit. It should be close to 4.00 mA. Use the ARROW keys to match the controller display with your meter reading and press OK.
- 4- Press F1 to calibrate 20.0mA output. The display should read about 20.0mA.
- 5- Use the ARROW keys to match the controller display to your meter reading then press F1 to save.
- 6- Press F1 to go to Next screen.
- 7- Choose another output or press ESC to return to the main display

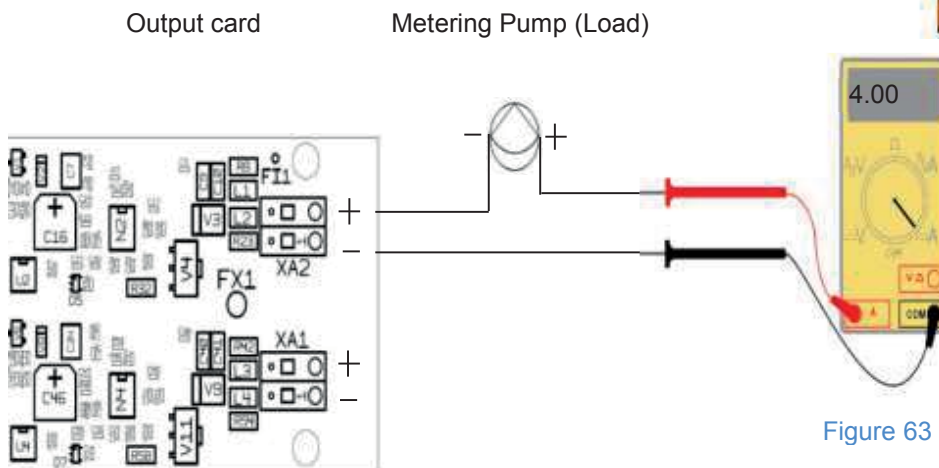
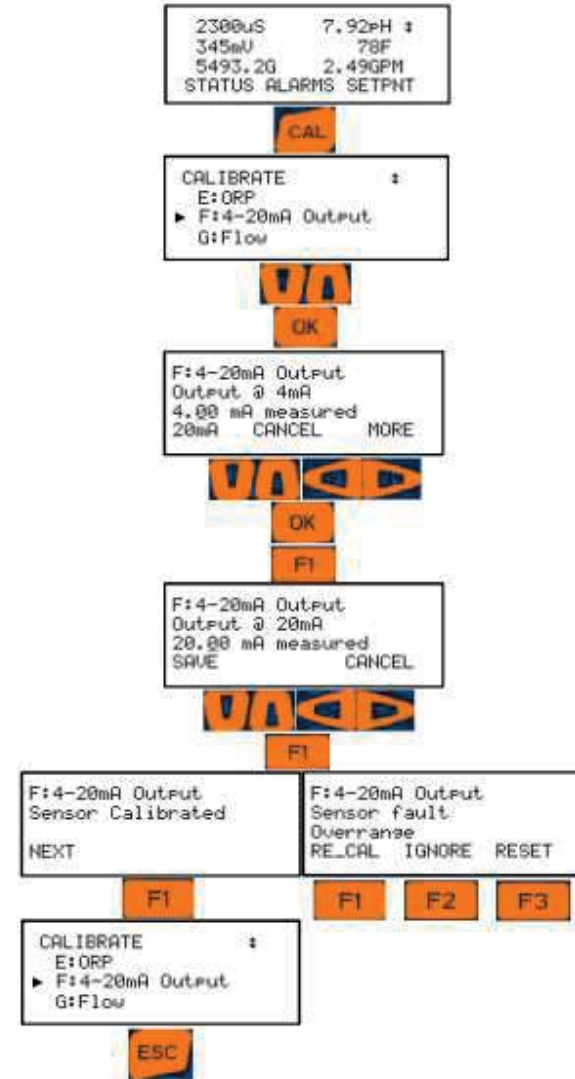

Figure 63

If the calibration was not successful (calibrate limits @ +/-0.5mA @ 4mA & +/-15% on span (about +/-2.4mA).) it will display “Sensor fault Overrange”, consider three choice after fault (**RECAL** to recalibrate, **IGNORE** to ignore the fault and accept calibration, **RESET** to reset calibration back to factory defaults)

# System Menu

## 11 System Menu

The System Menu is accessed by pressing the MENU key followed by the up arrow and the OK key. The following sections discuss the options available and how to edit the information. The options below appear in the order they are in the display if you use the down arrow to scroll.

The choices are:

- Communications
- System Setup
- Time and Date
- Set Sensor Type
- Enable I/O
- Passwords
- Activity Log
- Diagnostic
- Configurations

### 11.1 Communications

The Communications section has the IP addresses for the LAN and WiFi connections. Scroll down through; LAN IP Address, WiFi Netmask Address, WiFi IP Address, LAN Gateway, MAC Address and LAN Netmask.

Address Type	Default Setting
LAN IP Address	10.10.6.106
WiFi Netmask Address	255.255.255.0
WiFi IP Address	192.168.1.1
LAN Gateway	192.168.100.1
Mac Address	nn.nn.nn.nn.nn.nn
LAN Netmask	255.255.255.0

Table 15 IP Addresses

The LAN address and Netmask can be changed if the controller will be on a network. The network administrator must provide a LAN address for this device. Edit them here.

WiFi is how to connect wirelessly. Enable WiFi on your PC, Notebook or Smartphone.

The MAC address is assigned to the controller from the factory and cannot be changed. It is unique in the world.

### 11.1.1 How to Change the IP Address:

The factory default IP Address of the controller is 10.10.6.106.

You can connect any PC device with an Ethernet port to the controller using a CAT5 Ethernet cable.

Set up your device with a static IP address of 10.10.6.nnn, where, 'nnn' is a 3 digit number from 000 to 255 but not 106. 106 is the unique address of the controller.

Open a browser and enter 10.10.6.106 into the search box to make an HTTP connection to the controller.

Refer to the Browser manual for more details.

If your controller is attached to a local area network (LAN) the IP address of the controller will need to be changed to match the plant scheme. This address is assigned by the site IT staff.

Enter that address as shown here.

- 1- To Edit IP Address press **MENU**
- 2- Use Up/Down Arrows to navigate to **System** then press **OK**
- 3- Scroll to **Communication** then press **OK**
- 4- Use F1 to go to Edit Mode
- 5- Use Up/Down and Left/Right Arrow keys to Edit the IP Address then Press F1 to save the change
- 6- Press NEXT to go to Netmask setting
- 7- Use F1 to go to Edit Mode if necessary
- 8- Use Up/Down and Left/Right Arrow keys to Edit the Netmask then Press F1 to save the change
- 9- Use ESC key to exit and return to the main display

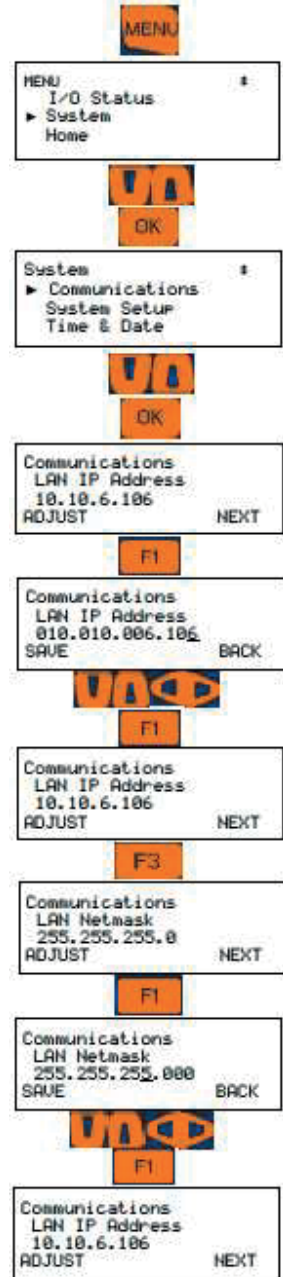



### 11.1.2 Web Interface Wi-Fi

PC's, tablets and phones can connect to the Aegis II via Wi-Fi.

The IP Address and Netmask for Wi-Fi is fixed (hard coded) so the only way to differentiate the connection between controllers is the Wi-Fi SSID #.

The SSID is the name you will see/connect to when using WiFi. From the factory, the last 3 digits of the name will be the same as the last 3 digits of the controller serial number. Should you be in an account that has multiple controllers, you need this to know which unit you are choosing a connection.

Once you are connected and logged in, you can change the SSID to anything you wish. The change will take place after you cycle power to the controller.

See flow chart below to find the fixed IP Address and Netmask for Wi-Fi

SSID: Service set identifier is a name for the wireless network.

The SSID cannot be edited from keypad. A Browser connection must be used.

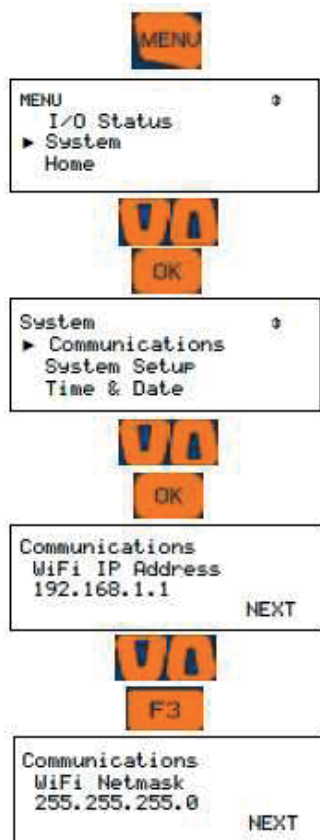

### 11.2 System Setup

System Setup has 9 options;

- Site Name
- Controller Name
- Keypad Passwords
- Metric Units
- Sunday = Day 1
- Number of Systems (Future)
- Alarm on Stops
- System Restart
- Factory Reset

#### 11.2.1 Site Name/Controller Name

You can label this device with two separate names. These names appear in any data file downloaded so as to help delineate these documents. The controller name also shows on the browser tab when connecting with a PC, tablet or Smartphone.

Edit these names using the keypad:

Notice the F2 key represents the word 'alpha'. You have three choices, ALPHA (upper case letters), alpha, (lower case letters), and NUMBERS, 0

through 9. Since the lower case 'alpha' is seen, please realize that this is a choice, not the current selection.

The default choice is upper case so use the up and down arrows to change the first digit. You will see the uppercase letters scroll by. Hold the key down for fast scroll, or press to move one letter at a time. Once you have rested on the letter you choose, press the right arrow to move to the next position.

Press the F2 key to choose **alpha**, lower case letters. Notice that the F2 choice now shows NUMBERS. That would be the next choice.

When finished, press **OK** to save.

#### 11.2.2 Keypad Passwords

Use this page to turn password protection ON/OFF. See section 11.6 **Passwords** to change your password, login or logout.

There are 4 Operator level, 3 Configure level and one Admin login.

The passwords allowed are the same on the keypad as those created/edited via a browser. You can edit

## System Menu

your password from either place.

Operator level users can see the program parameters but not edit them.

Configure level users and change all programming but cannot edit system parameters.

The Admin user can edit all user parameters.

There is not mfg password. If you forget your password, Prominent can reset the password list. All users would have to re-set their passwords.

User	Default PSW
Operator 1	1
Operator 2	2
Operator 3	3
Operator 4	4
Configure 5	5
Configure 6	6
Configure 7	7
Administrator	AAAA

Table 16 Default Users Passwords

### 11.2.3 Metric Units

Switch Engineering units to Metric.

### 11.2.4 Sunday=Day 1

Use this if you are setting up timers with a 28 day cycle. Since a 28 day cycle has 4 weeks of timers, setting this as week 1 lets you know that what you set up in week 1 will happen this coming week. (Every week is week 1 in a 7 day cycle.) See more in section [10.6.7 Choosing a Cycle](#)

### 11.2.5 Number of Systems

This is a function of the browser interface. Consult the browser manual.

### 11.2.6 Alarm on Stops

Pressing the **STOP** button at any time will stop all outputs. It will also create an alarm condition unless you change it.

### 11.2.7 System Restart and Factory Reset

System Restart will reset timers and clear alarms.

Factory Reset will perform a System restart plus all programming will be erased, the date and time will

be reset and the controller will reboot. Neither will reset passwords nor change IP addresses.

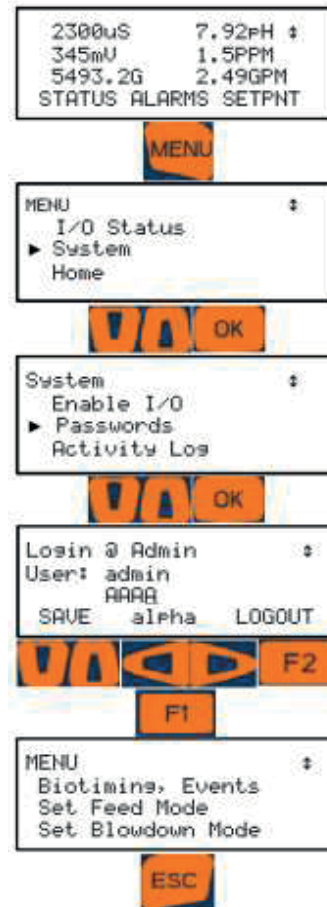

### 11.3 Time and Date:

To Set Time and Date:

- 1- Press **MENU**
- 2- Use Up/Down Arrows to navigate to System then press **OK**
- 3- Scroll to Time & Date then press **OK**
- 4- Use Up/Down and Left/Right Arrow keys to set the Time
- 5- Use **F3**, Up/Down and Left/Right Arrow keys to set Date
- 6- Use **F2**, Up/Down and Left/Right Arrow keys to set Week day then press **OK**
- 7- Use **ESC** key to Exit and back to main display

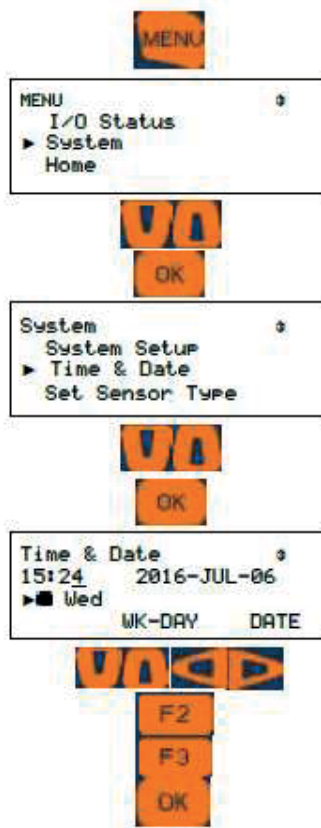

### 11.4 Set Sensor Type

Select the input letter then select the type.

### 11.5 Passwords – Login/Logout.

Use this section to change your password if the password option is enabled. If not enabled, See 11.2.2 **Keypad Passwords** to turn protection on/off.

#### 11.5.1 How to Set Keypad Password:

- 1- To Set Keypad password Press **MENU**
- 2- Use Up/Down Arrow keys to navigate to **SYSTEM** then press **OK**
- 3- Use Up/Down Arrow keys to navigate to **Passwords** then press **OK**
- 4- Use Up/Down and Left/right Arrow keys to set your desire password (F2 on alpha for lower case letter, F2 on Number for Digits, F2 on ALPHA for Capital letter), use F1 to save password

Keep in mind that the choice just before the button is pushed is the selected character type. Example: if the text above F2 says “alpha” pressing the F2 key once changes to lowercase.

Then use **F1** to save the change Use **ESC** key to Exit

### 11.6 Activity Log

**Note:** Most recent activities are shown first

- 1- To see the Activity Log, Press **MENU**
- 2- Use Up/Down Arrow keys to navigate to **SYSTEM** then press **OK**
- 3- Use Up/Down Arrow keys to navigate to **Activity Log** then press **OK**
- 4- Use **F3** to set the Date (this will be a date that you want to see the activity for all I/O)
- 5- Set the date using Navigation keys and then press **F1**
- 6- The activities will be shown based on the Letters (for inputs) and digits (for outputs)
- 7- Use **F1** key to go to Next activity and use Down arrow key to momentarily see the stamped time for that activity
- 8- Use **ESC** key to Exit

## Activity log steps

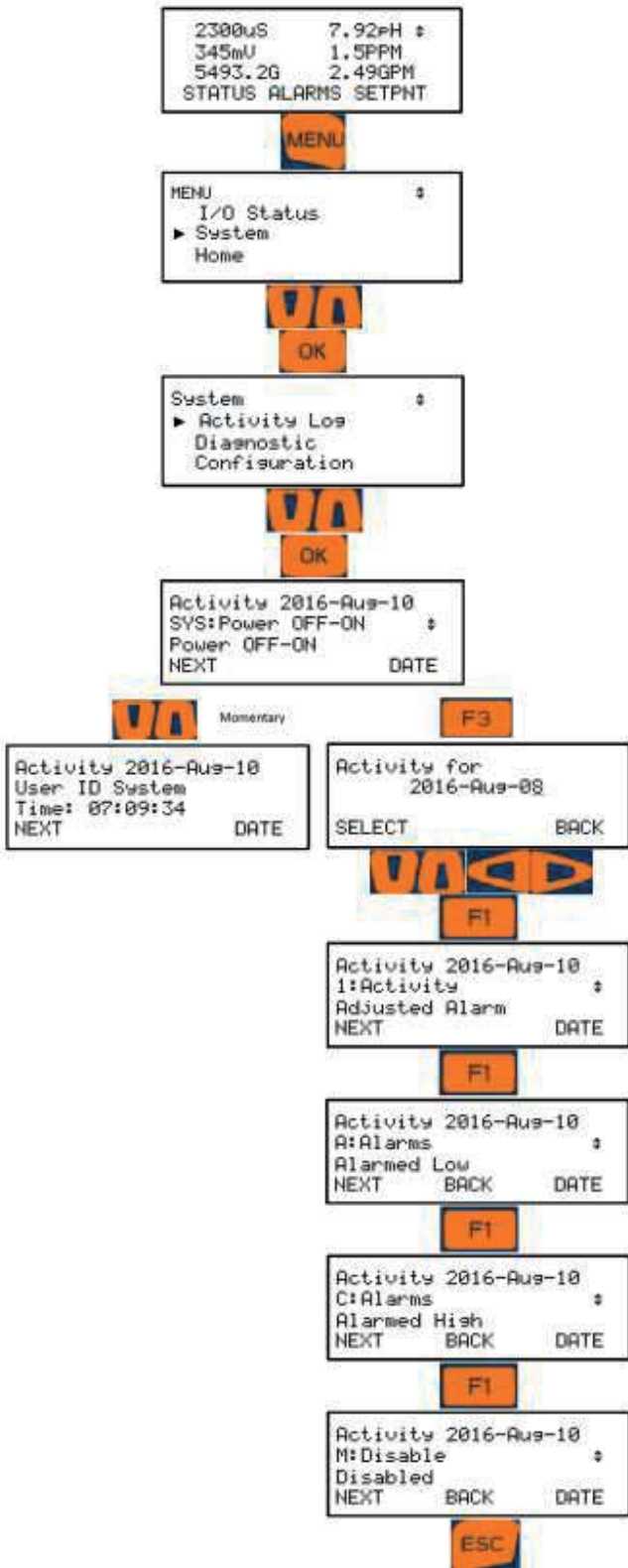

## 11.7 Diagnostics

**Serial #:** serial # of the controller

**Fan Speed:** displays fan speed, Monitoring fan if it fails will go to alarm

**O-V wiring:** 3 Wire meters only and if Digital input power supply fails because of miss-wiring.

Note: Digital input O-T share a different power supply than U and V.

**Admin Password:** Shows **Default** if it has not been modified from 'AAAA'. If modified, it will display 'Changed'.

**Watchdog Reset:** A **Watchdog Reset** should always display **0**. An increasing number of **Resets** indicates corrupted firmware or controller electrical fault or interference.

**Relay Fuse:** Displays the state of the Relay 1 and Relay 2 AC power fuse, Displays "Load Fuse open" if AC fuse is failed. The Board Fuse does not have an alarm. If it fails, the controller is without power.

**Home Inputs:** You can adjust which I/O points are displayed on the default menu.

See section 2.2 How to Modify the Display's 'Home' Screen.

**HMI Firmware:** Hood **Firmware Version** indicates the date of issue of the firmware operating the keypad and display (16.04.06.00 means 2016-April-6th)

**Firmware:** Mother board **Firmware Version** indicates the date of issue of the firmware operating the controller (16.08.01.00 means 2016-August-1st)

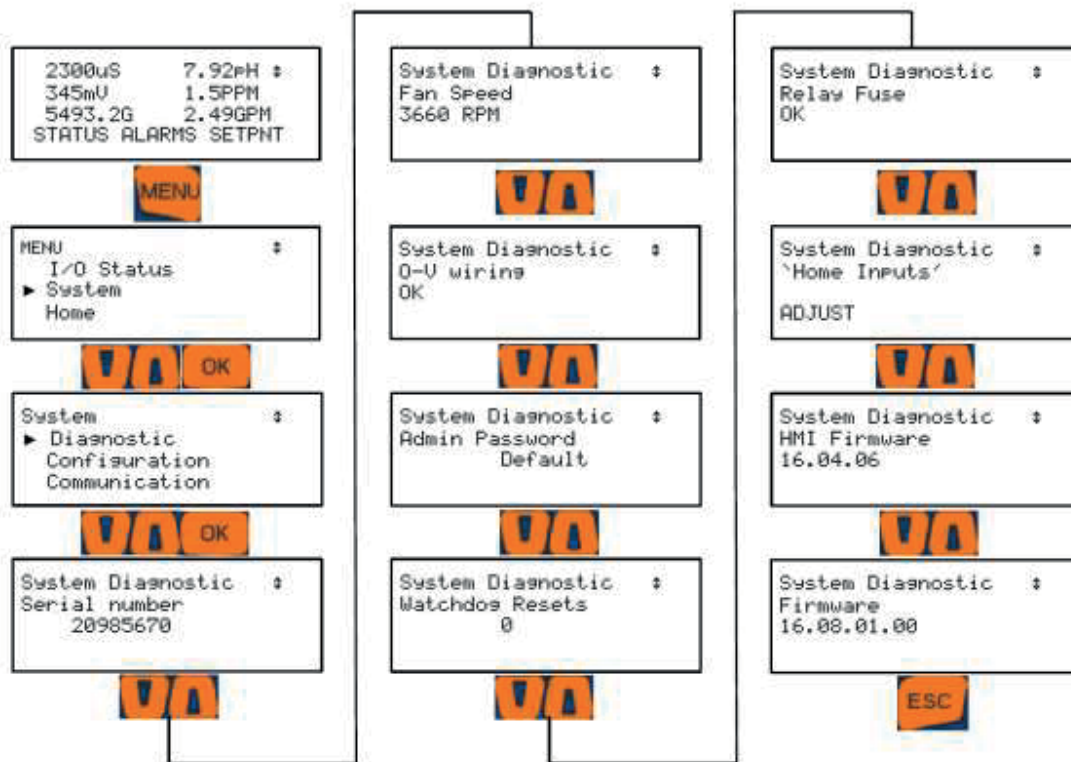

## 11.8 Configurations

See section [13.2.1 USB – Save or Load the Program](#)

## 12 Controller Technical Data:

### 12.1 Fuse Specification

The power relay fuse is 6.3 amps at 250 volts AC. This fuse is similar to the relay fuse used on the MultiFLEX and Aegis, except this is a slow blow fuse. Do not use this fuse in those controllers.

However, you can use the fast blow fuses provided with those controllers in the Aegis II. A fast blow fuse will not harm the device.

Component	Rating/type	vendor	Part#
Controller, Complete	100-230VAC, 50/60 Hz, 0.5-0.26A - No External Load	PFC	AGIb
Controller, Complete	100-230VAC, 50/60 Hz, 7.8A - with External Load	PFC	AGIb
Power relay R1,R2 and Power Out terminals	6.3 AT @250VAC 5x20mm, Slow-Blow, Glass Fuse	PFC	732379
Main Power Fuse	1.6AT 250VAC 5x20, 1.5 kA at 250 VAC ,Ceramic Fuse	PFC	732411
Enclosure	Rated for IP65	PFC	N/A

Table 17 Fuse Specifications

## System Menu

### 12.2 Controller Specifications

Description	Technical Data
Control characteristic:	ON/OFF, P, PID, Pulse Frequency control
Control:	9 Relays (see below)
Signal current output:	4-20 mA electrically isolated, max. load 450 $\Omega$ , range and assignment (measured, correction, control variable) can be set
Control output:	4 relays optional pulse frequency outputs or ON/OFF, for control of metering pumps
	2 relays Line Power 3 Relays dry contact
	6 Maximum x 4 ... 20 mA
Alarm relay:	Any relay can be programmed as an alarm
Electrical connection:	100-240 V, 50/60 Hz, 30 Watt
Ambient temperature:	Ambient temperature 0 ... 50 °C (for inside deployment or with a protective enclosure)
Degree of protection:	Wall mounted: Rated for IP 65
	NEMA 4X (leak-tightness)
Tests and certification:	CE, MET (corresponding to UL as per IEC 61010)
Material:	Housing PC with flame proofing configuration
Dimensions:	356 x 235 x 105 mm (WxHxD)
Weight:	net 2.1 kg
Wire sizes	Power: 14 to 18 gauge. Outputs R3, R4 & R5 up to 12 gauge. Frequency outputs and digital inputs: 14 to 24 gauge.

**Table 18 Controller Specifications**



#### **Fusing Relays R3, R4, and R5 for external power usage**

Relays R3, 4 and 5 can be wired using on-board power as shown in section [6.3.5.4 Wiring Relays R3 – R5 Using On-board Power](#) or powered from an external source as shown in section [6.3.5.5 Wiring Relays R3 – R5 Using an External Power Source](#). When using external power, fusing must be provided by customer.

These relays are rated for a maximum of 5 amps each when using external power.

## 12.3 Sensor Specifications

Measuring Range/Measured value	
Measuring range connection type mV:	pH: 0.00 ... 14.00
	ORP voltage: -1500 ... +1500 mV
Connection type mA (amperometric measured variables, measuring ranges according to the sensors):	Chlorine
	Bromine
	Peracetic acid
	Toroidal Conductivity
Connection type mV (potentiometric measured variables, measuring ranges according to the transmitters):	pH
	ORP millivoltage
Conductivity (variable ohm)	0 – 5,000 $\mu$ S
Conductivity (measuring ranges according to the transmitters):	0 – 5,000 $\mu$ S in a digital signal
Temperature:	via Pt 100/Pt 1000, measuring range 0 ... 150 °C
pH resolution:	0.01
ORP voltage:	1 mV
Temperature:	0.1 °C
Amperometric analysis	(Chlorine 0.001/0.01 ppm, 0.01 Vol. %, 0.1 Vol. % etc.):
Accuracy: based on the full-scale reading	0.3 %
pH/ORP measurement input:	Input resistance > 0.5 x 10 <sup>12</sup> $\Omega$
Correction variable:	Temperature via Pt 100/Pt 1000
Temperature compensation range:	0 ... 150 °C
pH compensation range for chlorine:	6.5 ... 8.5

Table 19 Sensor Specifications

### 13 Using the USB Port

#### 13.1 Capturing Data

The Aegis II logs all sensors, flow switches, meter values, relay ON times, fed volumes and status every 5 minutes. This data is easily captured from the USB port located behind the communication light cover.

- 1- Insert a USB flash drive into the USB port shown. The OLED screen will acknowledge the drive

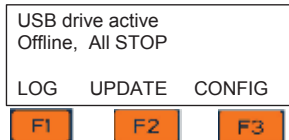

Phillips head screw



Figure 64 USB Access Door Closed [Top] and Open [Bottom]

- 2- Choose F1, LOG to set up the download.

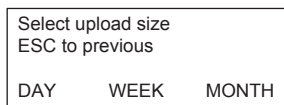

- 3- Choose the amount of history, DAY [F1], WEEK [F2], or MONTH [F3]. When you choose the period, the download starts.

*During the download, the keypad and browser connection are locked.*

- 4- The display will show the progress of the download

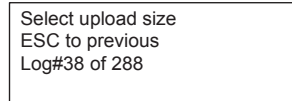

- 5- Once complete, the display will show the file name uploaded to the USB flash drive (ending in "csv"), the size of the file in number of records or time stamps, and instructs you to remove the drive to return the controller to normal operation.

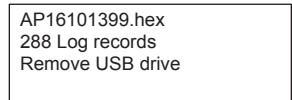

- 6- Don't forget to close and re-secure the access door to assure the interior of the controller is not subjected to moisture or corrosive fumes from the environment.

No special conversion program or Excel add-in is needed to import the CSV formatted data into Microsoft Excel<sup>®</sup> or similar spreadsheet programs. Refer to your spreadsheet or graphing software product to learn how to import CSV data. (CSV = Comma Separated Value)

Aegis II										
Serial number	Site name	Controller name		Firmware						
123	PFC	BW Test		1902352						
Log records										
I/O	Location	A	B	C	D	E	F	G	H	I
I/O	Units	uS		pH	mV	mA	mA	ppm	F	ppr
Date Da/Mo/Yr	Time	Conductivity	Unassigned	pH Sensor	ORP Sensor	pH mAOutput	ORP mAOu	Free Chlorin	Temperatur	CLE
3/8/2016	12:35:00	663.823	-100000	6.72	-5	3496.105	1200	-100000	-100000	
3/8/2016	12:30:00	661.725	-100000	6.71	-6	3505.023	1200	-100000	-100000	
3/8/2016	12:25:00	661.791	-100000	6.72	-7	3508.519	1200	-100000	-100000	
3/8/2016	12:20:00	661.871	-100000	6.73	-5	3503.924	1200	-100000	-100000	

Table 20 Partial example of captured data



### 13.2 Firmware Upgrade using USB

If necessary, your controller can have the firmware upgraded. Firmware is a set of instructions which tell the controller CPU how to operate.

- 1- Obtain the hex file from Prominent and insert thumb drive with the new file into the USB port located behind the Communication panel. See section 13 Capturing Data.
- 2- Press **F2**, UPDATE

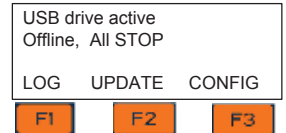

- 3- The display shows the current hex file in use. "NEWPGM" is a list of hex programs on the drive. If NEWPGM is not a choice, there are no compatible hex files on the USB drive. "OLDPGM" is a list of hex programs on the Aegis. If OLDPGM is not a choice, there are no other backup hex files in the Aegis memory. Choose New or Old to see a list of hex files.

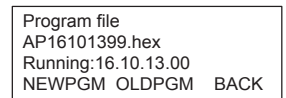

- 4- Press **F2** to scroll through the list of hex files. Press **F1**, Load to install the new hex file.

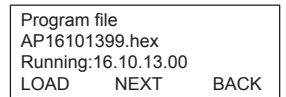

- 5- Remove the USB drive when prompted.

NOTE: OLDER FIRMWARE VERSIONS USE STEP 6.

- 6- The firmware is copied to the controller. When complete Aegis will notify you to remove the USB drive.

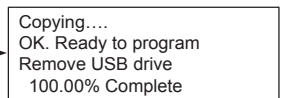
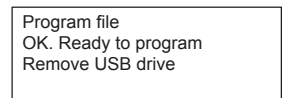
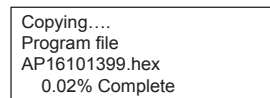

- 7- After you remove the drive, the controller will erase the existing firmware and install the new one.

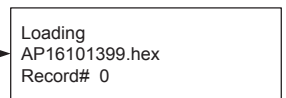
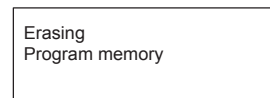

- 8- Once the new firmware is installed, the controller will restart.



#### 13.2.1 USB – Save or Load the Program

A program is a list of instructions that the user can edit. Set-points, calibrations, names of I/O are all saved in the program.

##### 13.2.1.1 Saving to the USB

- 1- To **save** a copy of your current program onto a USB drive, insert a USB into the USB port located behind the Communication panel. See section 13 Capturing Data.

- 2- Press **F3** Config

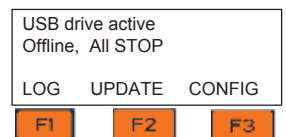

- 3- If you have not previously saved a program on this USB you can only **F1** SAVE a copy to the USB.

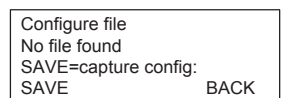

- 4- If you have a previously saved program, you have the choice of saving **F1** or loading **F3**.

```
Configure file
AC123_16_292.cfg
SAVE=capture config:
SAVE      NEXT      LOAD
```

In either case, press **F1** SAVE to copy the current configuration to the USB drive. When the save is complete, the display will notify you to remove the USB drive.

```
AC123_16_292.cfg
complete
Remove USB drive
```

### 13.2.1.2 Loading from the USB

- 1- To load a previously saved program from the USB to your controller, press **F3** Load.

```
Re-configure file
Writing 6
SAVE=capture config:
SAVE      NEXT      LOAD
```

- 2- The controller loads the program from your USB and notifies you to remove it.

```
AC123_16_292.cfg
Complete restarts
Remove USB drive
```

Sometimes referred to as “Cloning”, a saved program file can be loaded onto a different Aegis II controller. They will then have the same configuration.

## 13.3 E-mail Reports and Alarms

The E-mail function is explained in the Aegis II Browser manual. You cannot access this feature through the keypad. The following explanation is for informational purposes only.

The E-mail tool can send three types on information; Alarms, Status and Daily data. Setup is via a PC or smart phone browser.

During controller power up or reset, E-mail initializes as disabled.

### 13.3.1 E-mail Types:

- 13.3.1.1 ALARM: Sent once when an alarm first occurs.

Lists all active alarms.  
Includes enabled sensor, meter & contact values for alarm context  
User Enabled/Disabled.

- 13.3.1.2 STATUS: Sent @ noon every day (12:00). Verifies that the controller is running & on the LAN.

Includes enabled sensor, meter & contact values.  
Sent @ midday so that commercial systems will have some run time and some day is left to respond to operating issues.

- 13.3.1.3 DAILY: Sent @ midnight (23:59) every day. Verifies that the controller is running & on the LAN.

Includes enabled output run times or volumes and sensor, meter & contact values. User Enabled/Disabled.  
All types send comma delimited values(CSV); one line per I/O or Alarm so that the both the subject & body can be easily parsed into a logging app, a typical use for the DAILY type.  
Will make text-to-speech entertaining (bit encoded value-states are therefore intentionally excluded).

## 14 Spare Parts and Accessories

### Aegis II Controller

Power supply 100-230V 5V 55W RPS-60-5	734526
Keypad Aegis II	1050746
Ribbon cable 10P 2 socket 185mm	1050827
LCD module 100x40 OLED 5V with cable	734486
Pc-board Aegis II	734190
Assy.El.Aegis II HMI	734260
A2 dual mA Input driver	734126
A2 dual mA Output driver	734143
A2 dual pH/temp Input driver	734131
A2 dual cond/temp Input driver	734223
A2 dual serial sensor Input driver	734265
A2 pH/w temp and mA Input driver	734355
A2 WLAN (WiFi module)	734211
Bluetooth-module (not currently available. Jan 2017)	734233
Battery BR2032	732829
USB 2.0 cable conn. A and Mini-B	1058522
A2 Fuse – Main Power 1.6A Ceramic 5x20mm	732411
A2 Fuse – Relays 6.3A slow blow 5x20glas	732379

### Sensors and Accessories

#### Serial CTFS sensor (Conductivity-Temperature-Flow)

CTFS Sensor <b>Assembly</b> (includes next 4 items)	7500979
Cond-Temp-Flow Serial Sensor	7761529
O-Ring seal for CTFS/CTF/TF Ass'y	7760577
Sensor entry fitting CTFS/CTF/TF	7760445
3/4" PVC Tee TxTxT Sch80	7741484

#### Serial Corrosion Sensor (LPR)

LPR Sensor <b>Assembly. No Tips</b> w/Tee, entry fit, O-Ring	7761473
LPR Sensor Only. No tips 125 psi 50°C	7760792
O-Ring seal for CTFS/CTF/TF Ass'y	7760577
Sensor entry fitting CTFS/CTF/TF	7760445
3/4" PVC Tee TxTxT Sch80	7741484
Admiralty Brass corr replc tips set w/Oring CRS-AM	7760238
Cupro/Nickle corr replc tip set w/Oring CRS-CN	7760239
Carbon Steel corr replc tip set w/Oring CRS-CS	7760240
Copper corr replc tip set w/Oring CRS-CU	7760241
304SS corr replc tip set w/Oring CRS-SS	7760243
Zinc corr replc tip set w/Oring CRS-ZN	7760244



Figure 65 LPR serial sensor assembly includes Tee, O-ring entry fitting and shown with tips

**Potentiometric Sensors and Accessories**

PHED 112 SE sensor	741036
RHEP Pt SE ORP sensor	150094
Coax cable, SN2 x Clamp, 32"	1024105
Coax cable, SN2 x Clamp, 6'	1024106
Coax cable, SN2 x Clamp, 30'	1024107
PHED/RHEP Long body probe holder	7746422
¾" PVC Tee TxTxT Sch80	7741484
Metric PHED/RHEP long body probe holder w/T	1001493
PHED to 4-20mA converter	809126
RHEP to 4-20mA converter	809127
Conduct sens, boiler 2/wire 250psi, ¾" NPT,	7760189
Conductivity/Temp 4-wire, 250psi @ 450°F condensate	7760191
Conductivity boiler ¾" cast iron Tee	7760384
Resistance thermometer Pt-100-SE	305063
Resistance thermometer Pt-1000-SE	1002856
Temp Sensor, SGT, H2O Grnd 316SS ¼" MNPT 36"	1051505
Temperature transducer 4-20mA Pt100 V1	809128

**Cable**

Cable, 2 conductor 22ga Quantity in feet	7760527
--	---------

Use this cable to lengthen 2-wire boiler probe wire or any 4-20mA signal.

**Amperometric Sensors and Accessories**

CLE 3-mA-2 ppm sensor 0.02 to 2.0 mg/l	792920
CLE 3-mA-10 ppm sensor 0.10 to 10.0 mg/l	792919
CLO 1-mA-2 ppm sensor 0.02 to 2.0 mg/l	1033871
CLO 1-mA-10 ppm sensor 0.10 to 10.0 mg/l	1033870
CGE 3-mA-2 ppm sensor 0.02 to 2.0 mg/l	1047959
CGE 3-mA-10 ppm sensor 0.10 to 10.0 mg/l	1047975
CTE 1-mA-2 ppm sensor 0.02 to 2.0 mg/l	740685
CTE 1-mA-10 ppm sensor 0.10 to 10.0 mg/l	740684
CBR 1-mA-2 ppm sensor 0.02 to 2.0 mg/l	1038015
CBR 1-mA-10 ppm sensor 0.10 to 10.0 mg/l	1038014
PAA 1-mA-200 ppm sensor 1 to 200 mg/l	1022506
PAA 1-mA-2000 ppm sensor 1 to 2000 mg/l	1022507
Membrane cap for CLE3	790488
Sensor cap for CLO 1	1035197
Membrane cap for CGE/CTE 1	792862
Membrane cap for CBR 1	741274
Diaphragm cap for PAA 1	1023895

Accessory set CGE 2/CTE 1 (2/5/10ppm) 2 caps/elect	740048
Accessory set CLE (2 mem caps + 100mL electrolyte)	1024611
Accessory set PAA 1 (2 mem caps + 100mL electrolyte)	1024022
Accessory set CLO 1 (100mL electro, grinding disc. Plug)	1035482
Accessory set CBR 1 (2 mem caps + 100mL electrolyte)	1038984
Electrolyte for all CLE chlorine sensors 100mL	506270
Electrolyte CGE/CTE/BRE sensors 50mL	792892
Electrolyte PAA 1 100mL	1023896
Electrolyte CLO 1 100mL	1035191
Electrolyte CBR 1 100mL	1038017

### Watermeters

Size	For Cooling - Contact Head	For Cooling - Paddlewheel	For Hot Water - Paddlewheel
.75"	7760518	7760514	7760277
1"	7760515	7760508	7760279
1.5"	7760516	7760509	7760278
2"	7760517	7760510	7760280
3"	NA	7760511	7760281
4"	NA	7760512	7760282
6"	NA	7760513	NA

Table 21 Watermeters

## 15 Maintenance

The Aegis II Controller is maintenance free. Replace the battery after 10 years as a precautionary measure. Battery type: BR2032, 3 V approx. 190 mAh

The battery is clamped in a holder on the Top center of the main board

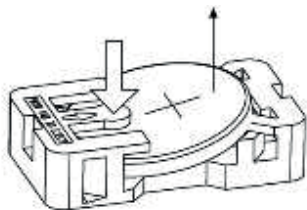

### NOTICE!

#### Hazardous waste

The battery is hazardous waste. It must be disposed of separately. Observe the conditions which apply on your site.

Figure 66 Aegis battery

### Removing the battery

1. Unscrew the four retaining screws at the front on the housing upper section and take the housing upper section off from the housing lower section.
2. Press on the holder lug to release the battery from the holder, see Fig. 66
3. Insert a new battery in the holder, In so doing avoid pressing with the fingers on the battery poles. This will result in poor contacts.
4. Place the housing upper section on the housing lower section
5. Manually tighten the four retaining screws



**CAUTION!**

**Solvent**

Do not under any circumstances use solvent to clean the surfaces. Solvent can attack the surfaces.

Clean the housing with a damp cloth. Then rub dry.

## 16 Certifications

The Aegis II Controller is built to conform to UL/CSA/IEC 61010-1 for safety. Additional information can be found on our website [www.prominent.us](http://www.prominent.us).

This device complies with Industry Canada license-exempt RSS standard(s). Operation is subject to the following two conditions: (1) this device may not cause interference, and (2) this device must accept any interference, including interference that may cause undesired operation of the device.

Le présent appareil est conforme aux CNR d'Industrie Canada applicables aux appareils radio exempts de licence. L'exploitation est autorisée aux deux conditions suivantes: (1) l'appareil ne doit pas produire de brouillage, et (2) l'utilisateur de l'appareil doit accepter tout brouillage radioélectrique subi, même si le brouillage est susceptible d'en compromettre le fonctionnement.



## 17 Necessary formalities

### 17.1 Disposal of used parts

Users' qualification: instructed persons, see [Section 4.4 Users' qualifications](#).

#### **NOTICE!**

Regulations governing disposal of used parts

– Note the current national regulations and legal standards which apply in your country

### 17.2 Agency Approvals

Safety: UL 61010-1, 3<sup>rd</sup> Edition  
CSA C22.2 No. 61010-1-12, 3<sup>rd</sup> Edition  
IEC 61010-1, 3<sup>rd</sup> Edition  
EN 61010-1, 3<sup>rd</sup> Edition

ProMinent Fluid Controls, Inc.  
136 Industry Drive  
Pittsburgh, PA 15275-1014  
412.787.2484  
[www.prominent.us](http://www.prominent.us)