

DULCOMETER®, Compact Controller
Measurement: Inductive conductivity

EN



A1860

Please carefully read these operating instructions before use. · Do not discard.
The operator shall be liable for any damage caused by installation or operating errors.
The latest version of the operating instructions are available on our homepage.

General non-discriminatory approach

In order to make it easier to read, this document uses the male form in grammatical structures but with an implied neutral sense. It is aimed equally at both men and women. We kindly ask female readers for their understanding in this simplification of the text.

Supplementary information

 Please read the supplementary information in its entirety.

Information







This provides important information relating to the correct operation of the unit or is intended to make your work easier.

Warning information

Warning information includes detailed descriptions of the hazardous situation, see  *Chapter 3.1 'Labelling of Warning Information' on page 11.*

The following symbols are used to highlight instructions, links, lists, results and other elements in this document:

Tab. 1: More symbols

Symbol	Description
	Action, step by step.
	Outcome of an action.
	Links to elements or sections of these instructions or other applicable documents.
	List without set order.
<i>[Button]</i>	Display element (e.g. indicators). Operating element (e.g. button, switch).

Symbol	Description
<i>'Display /GUI'</i>	Screen elements (e.g. buttons, assignment of function keys).
CODE	Presentation of software elements and/or texts.

Table of contents

1	Identity code	7
2	Introduction	9
	2.1 Measured variables.....	9
3	Safety and responsibility	11
	3.1 Labelling of Warning Information.....	11
	3.2 General Safety Information.....	12
	3.3 Intended Use.....	14
	3.4 User qualification.....	15
4	Functional description	17
5	Assembly and installation	18
	5.1 Scope of delivery.....	18
	5.2 Assembly and installation.....	18
	5.3 Assembly (mechanical).....	20
	5.3.1 Wall mounting.....	20
	5.3.2 Pipe mounting.....	21
	5.3.3 Control panel mounting.....	22
	5.4 Installation (electrical).....	30
	5.4.1 Cable Cross-Sections and Cable End Sleeves.....	31
	5.4.2 Electrical connection of the conductivity sensor.....	31
	5.4.3 Terminal diagram / wiring.....	32
	5.4.4 Installation (electrical).....	39
	5.5 Switching of inductive loads.....	40
6	Sensor connector	42
7	Commissioning	45
	7.1 Initial commissioning.....	45
	7.2 Setting the control during commissioning.....	45
	7.3 Selecting the sensor type	46
	7.4 Temperature compensation and reference temperature.....	48
8	Operating diagram	50
	8.1 Overview of equipment/Operating elements.....	50
	8.2 Entering values.....	51
	8.3 Adjusting display contrast.....	52
	8.4 Continuous display.....	53

8.5	Information display.....	54
8.6	Password.....	55
9	Operating menus.....	56
9.1	Calibrating <i>[CAL]</i> the conductivity sensor.....	56
9.1.1	Calibration of the cell constant.....	58
9.1.2	Calibration of the temperature coefficient.....	61
9.1.3	Calibrating the zero point.....	64
9.2	Setting limit values <i>[LIMITS]</i>	66
9.3	Setting the control <i>[CONTROL]</i>	69
9.4	Setting inputs <i>[INPUT]</i>	72
9.5	Setting the <i>[MANUAL]</i> sensor in the <i>[INPUT]</i> menu.....	77
9.6	Setting outputs <i>[OUTPUT]</i>	81
9.7	Setting the <i>[DEVICE]</i>	85
10	Control parameters and functions.....	87
10.1	DULCOMETER® Compact Controller function states	87
10.2	<i>[STOP/START]</i> key.....	89
10.3	Priming <i>[PRIME]</i>	90
10.4	Hysteresis limit value.....	91
10.5	Temperature correction variable.....	92
10.6	Checkout time for measured variable and correction variable.....	93
10.7	Checkout time control.....	93
10.8	Power relay "P-REL" as limit value relay.....	94
10.9	Setting and functional description of "Relay Used as a Solenoid Valve" ..	95
10.10	Alarm relay.....	97
10.11	"Error logger" operating mode.....	97
11	Maintenance.....	98
11.1	Error messages	98
11.2	Changing the fuse, DULCOMETER® Compact Controller.....	102
12	Technical data on DULCOMETER® Compact Controller.....	103
12.1	Permissible ambient conditions.....	103
12.2	Dimensions and weights.....	103
12.3	Material data.....	104
12.4	Chemical Resistance.....	104
12.5	Sound Pressure Level.....	104
13	Electrical data.....	105

Table of contents

14	Spare parts and accessories	109
15	Replacing spare part units	110
15.1	Replacing the top part of the housing.....	110
15.2	Replacing the lower part of the housing (wall/tube retaining bracket).....	112
15.3	Replacing the lower part of the housing (control panel installation).....	115
16	Standards complied with and Declaration of Conformity	118
17	Disposal of used parts	119
18	Index	120

1 Identity code

DCCa	DULCOMETER® Compact,		
	Mounting type		
E	Spare part units		
W	Wall/pipe mounting IP 67		
S	With fitting kit for control panel mounting IP 54		
	Design		
00	With ProMinent® logo		
E1	Spare part unit, controller housing lower part (processor/PCB), fully assembled		
E2	Spare part unit, controller housing top part (processor/PCB), fully assembled		
	Operating voltage		
6	90 ... 253 V, 48/63 Hz		
	Measured variable		
C0	Free chlorine		
NG	pH/ORP (switchable)		
L3	Conductive conductivity (designation: COND_C)		
L6	Inductive conductivity (designation: COND_I)		
	Hardware extension		
0	None		
	Approvals		
01	CE (Standard)		
	Certificates		
0	None		
	Operating instructions language		
EN	German	KR	Korean

Identity code

DCCa		DULCOMETER® Compact,							
						EN	English	LT	Lithuanian
						ES	Spanish	LV	Latvian
						IT	Italian	NL	Dutch
						FR	French	PL	Polish
						FI	Finish	PT	Portuguese
						BG	Bulgarian	RO	Romanian
						ZH	Chinese	SV	Swedish
						CZ	Czech	SK	Slovakian
						EL	Greek	SL	Slovenian
						HU	Hungarian	RU	Russian
						YES	Japanese	TH	Thai

2 Introduction

Data and functions

These operating instructions describe the technical data and functions of the DULCOMETER® Compact Controller, measured variable: Inductive conductivity

2.1 Measured variables

The controller can process the following measured variables:

- Inductive conductivity [*ConI*]
- Resistance [*RES*]
- TDS value [*TDS*]
- Salinity [*SAL*]

Switching between measured variables

Use the  key to switch between the controller's measured variables [*ConI*], [*RES*], [*TDS*] and [*SAL*] in the continuous display.

Depending on the measured variable set, the settings of variables are changed or the variables are hidden completely in the [*INPUT > TCOMP*] menu and in the [*LIMIT*] menu.

Measured variable: Inductive conductivity [*ConI*]

Symbol displayed in the controller's display: [*ConI*]

Units of measurement: $\mu\text{S/cm}$, mS/cm , S/cm . The measuring range is automatically detected and switched by the controller

Physical variable: specific electrical conductivity (K). Only this measured variable and the correction variable 'Temperature' are emitted at the mA output, independently of the measured variable set on the controller. The setting of the measured variable on the controller only affects the layout of the display and not the output at the mA output.

Measured variable: Resistance [*RES*]

Symbol displayed in the controller's display: [*RES*]

Units of measurement: $\text{M}\Omega\text{cm}$, $\text{k}\Omega\text{cm}$, Ωcm . The measuring range is automatically detected and switched by the controller

Physical variable: specific electrical resistance.

Calculating the specific resistance: $\rho (T_{\text{ref}}) = 1/K (T_{\text{ref}})$

Measured variable: TDS value

Symbol displayed in the controller's display: *[TDS]* (total dissolved solids)

Unit of measurement: ppm (mg/l)

Physical variable: Total of all inorganic and organic substances dissolved in a solvent

Display range: 0 2000 ppm

Temperature range: 0 ... 35 °C

[TLIMIT↑]: ≤ 40 °C

Setting the TDS value displayed: You can set a multiplicative factor *[TDS]* in the *[INPUT]* menu, with which the TDS value displayed can be changed.

Displayed TDS value *[ppm]* = K (25 °C) *[μ S/cm]** TDS factor

Setting range of TDS factor: 0.400 ... 1.000 (Default: 0.640)

Temperature compensation is always linear on the TDS display with a reference temperature of 25 °C.

Measured variable: Salinity (SAL)

Symbol displayed in the controller's display: *[SAL]* units: ‰ (g/kg)

Physical variable: Mass of salts in one kg of water given in PSU (practical salinity units).

The salinity is derived from the conductivity measured, with a specified non-linear temperature compensation and a reference conductivity (KCL).

Display range: 0 70.0 ‰

Temperature range: 0 ... 35 °C

[TLIMIT↑]: ≤ 35 °C

The salinity *[SAL]* is calculated based on the *[Practical Salinity Scale 1978 (PSS-78)]*

3 Safety and responsibility

3.1 Labelling of Warning Information

Introduction

These operating instructions provide information on the technical data and functions of the product. These operating instructions provide detailed warning information and are provided as clear step-by-step instructions.

The warning information and notes are categorised according to the following scheme. A number of different symbols are used to denote different situations. The symbols shown here serve only as examples.



DANGER!

Nature and source of the danger

Consequence: Fatal or very serious injuries.

Measure to be taken to avoid this danger.

Description of hazard

- Denotes an immediate threatening danger. If the situation is disregarded, it will result in fatal or very serious injuries.



WARNING!

Nature and source of the danger

Possible consequence: Fatal or very serious injuries.

Measure to be taken to avoid this danger.

- Denotes a possibly hazardous situation. If the situation is disregarded, it could result in fatal or very serious injuries.



CAUTION!

Nature and source of the danger

Possible consequence: Slight or minor injuries. Material damage.

Measure to be taken to avoid this danger.

- Denotes a possibly hazardous situation. If the situation is disregarded, it could result in slight or minor injuries. May also be used as a warning about material damage.

NOTICE!

Nature and source of the danger

Damage to the product or its surroundings.

Measure to be taken to avoid this danger.

- Denotes a possibly damaging situation. If the situation is disregarded, the product or an object in its vicinity could be damaged.



Type of information

Hints on use and additional information.

Source of the information. Additional measures.

- *Denotes hints on use and other useful information. It does not indicate a hazardous or damaging situation.*

3.2 General Safety Information



WARNING!

Live parts!

Possible consequence: Fatal or very serious injuries

- Measure: Disconnect the mains power supply prior to opening the housing
- De-energise damaged, defective or manipulated units by disconnecting the mains plug



WARNING!

Unauthorised access!

Possible consequence: Fatal or very serious injuries

- Measure: Ensure that there can be no unauthorised access to the unit



WARNING!

Operating errors!

Possible consequence: Fatal or very serious injuries

- The unit should only be operated by adequately qualified and technically expert personnel
- Please also observe the operating instructions for controllers and fittings and any other component groups, such as sensors, measuring water pumps ...
- The operator is responsible for ensuring that personnel are qualified



CAUTION!

Electronic malfunctions

Possible consequence: Material damage to destruction of the unit

- The mains connection cable and data cable should not be laid together with cables that are prone to interference
- Measure: Take appropriate interference suppression measures



NOTICE!

Correct and proper use

Damage to the product or its surroundings

- The unit is not intended to measure or regulate gaseous or solid media
- The unit may only be used in accordance with the technical details and specifications provided in these operating instructions and in the operating instructions for the individual components



NOTICE!

Correct sensor operation / Run-in time

Damage to the product or its surroundings

- Correct measuring and dosing is only possible if the sensor is working perfectly
- It is imperative that the run-in times of the sensors are adhered to
- The run-in times should be allowed for when planning initial operation
- It may take a whole working day to run-in the sensor
- Please read the operating instructions for the sensor

! NOTICE!

Correct sensor operation

Damage to the product or its surroundings

- Correct measuring and dosing is only possible if the sensor is working perfectly
- Check and calibrate the sensor regularly

! NOTICE!

Compensation of control deviations

Damage to the product or its surroundings

- This controller cannot be used in control circuits which require rapid compensation (< 30 s)

3.3 Intended Use

! NOTICE!

Intended Use

The device is designed to measure and regulate liquid media. The designated measured variable is detailed on the controller and is absolutely binding.

The unit should only be used in accordance with the technical data and specifications provided in these operating instructions and in the operating instructions for the individual components (such as sensors, fittings, calibration devices, metering pumps etc.).

Any other uses or modifications are prohibited.

! NOTICE!

Compensation for control deviations

Damage to the product or its surroundings

- The controller can be used in processes, which require compensation of > 30 seconds

3.4 User qualification



WARNING!

Danger of injury with inadequately qualified personnel

The operator of the system / equipment is responsible for ensuring that the qualifications are fulfilled.

If inadequately qualified personnel work on the unit or loiter in the hazard zone of the unit, this could result in dangers that could cause serious injuries and material damage.

- All work on the unit should therefore only be conducted by qualified personnel.
- Unqualified personnel should be kept away from the hazard zone.

The pertinent accident prevention regulations, as well as all other generally acknowledged safety regulations, must be adhered to.

Training	Definition
Instructed personnel	An instructed person is deemed to be a person who has been instructed and, if required, trained in the tasks assigned to him and possible dangers that could result from improper behaviour, as well as having been instructed in the required protective equipment and protective measures.
Trained user	A trained user is a person who fulfils the requirements made of an instructed person and who has also received additional training specific to the system from the manufacturer or another authorised distribution partner.
Trained, qualified personnel	A trained, qualified employee is deemed to be a person who is able to assess the tasks assigned to him and recognize possible hazards based on his training, knowledge and experience, as well as knowledge of pertinent regulations. A trained, qualified employee must be able to perform the tasks assigned to him independently with the assistance of drawing documentation and parts lists. The assessment of a person's technical training can also be based on several years of work in the relevant field.

Safety and responsibility

Training	Definition
Electrical technician	An electrical technician is able to complete work on electrical systems and recognise and avoid possible dangers independently based on his technical training and experience as well as knowledge of pertinent standards and regulations. An electrical technician must be able to perform the tasks assigned to him independently with the assistance of drawing documentation, parts lists, terminal and circuit diagrams. The electrical technician must be specifically trained for the working environment in which the electrical technician is employed and be conversant with the relevant standards and regulations.
Service	The Service department refers to service technicians, who have received proven training and have been authorised by the manufacturer to work on the system.

4 Functional description

Brief functional description

The controller for the measured variable inductive conductivity provides the basic functions for water treatment applications. The controller has a fixed configuration with the following features:

- Language-independent operation. Use of abbreviations, such as:
 - *[INPUT]*
 - *[OUTPUT]*
 - *[CONTROL]*
 - *[ERROR]*
- Illuminated display
- 3 LEDs indicate the operating statuses:
 - *[f-REL]*, active
 - *[P-REL]*, active
 - Error
- Control characteristics:
 - P, or
 - PID
- Selectable control direction:
 - Raise measured value, or
 - Lower measured value
- Pulse frequency relay *[f-REL]* for control of the metering pump
- Output relay *[P-REL]*, configurable as:
 - Alarm
 - Limit value
 - Pulse width-modulated (PWM) control output for metering pumps
- Analog output 0/4...20 mA, configurable:
 - Measured value (conductivity only), or
 - Correction variable
- Priming function for all actuators

- Digital input to switch off the controller or to process a sample water limit contact by remote control
- Temperature sensor input (Pt 100 or Pt 1000) for temperature compensation
- Degree of protection
 - IP67 (wall / pipe mounting)
 - IP54 (control panel mounting)

Applications:

- Bleeding of for example air scrubbers and chillers
- General water treatment, for instance, the monitoring of rinsing baths

5 Assembly and installation

5.1 Scope of delivery

The following parts belong to the standard scope of delivery of a DULCOMETER® Compact Controller.

Description	Quantity
Assembled device	1
Cable connection set DMTa/DXMa (metr.)	1
Operating instructions	1

5.2 Assembly and installation

- **User qualification, mechanical installation:** trained qualified personnel, see *Chapter 3.4 'User qualification' on page 15*
- **User qualification, electrical installation:** Electrical technician, see *Chapter 3.4 'User qualification' on page 15*

CAUTION!

Possible consequence: Material damage.

The hinge between the front and rear part of the housing cannot absorb high levels of mechanical loading. When working on the controller, hold the top section of the controller housing firmly.

NOTICE!

Mounting position and conditions

- Only carry out the (electrical) installation after the (mechanical) installation
- Ensure that there is unimpeded access for operation
- Ensure safe and low-vibration fixing
- Avoid direct sunlight
- Permissible ambient temperature of the controller at the installation location: - 10 ... 60°C at max. 95 % relative air humidity (non-condensing)
- Take into consideration the permissible ambient temperature of the sensors connected and other components



Read-off and operating position

- *Install the unit in a favourable position for reading and operation (preferably at eye level)*



Mounting position

- *Leave sufficient free space for the cables*



Packaging material

Dispose of packaging material in an environmentally responsible way. All packaging components carry the corresponding recycling code ♻️.

5.3 Assembly (mechanical)

The DULCOMETER® Compact Controller is suitable for mounting on a wall, pipe or control panel.

Tab. 2: Mounting materials (contained in the scope of delivery):

Description	Quantity
Wall/tube retaining bracket	1
Half-round head screws 5x45 mm	2
Washer 5.3	2
Rawlplug Ø 8 mm, plastic	2

5.3.1 Wall mounting

Mounting (mechanical)

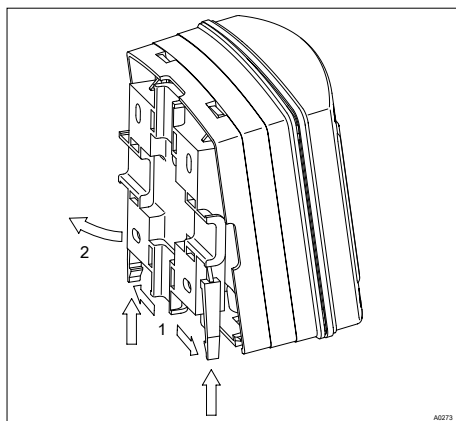

Fig. 1: Removing the wall/pipe bracket

1. Remove the wall/pipe bracket. Pull the two snap-hooks (1) outwards and push upwards
2. Fold out the wall/pipe bracket (2) and pull out in a downwards direction
3. Mark two drill holes diagonal to each other by using the wall/pipe bracket as a drilling template
4. Drill holes: Ø 8 mm, d = 50 mm

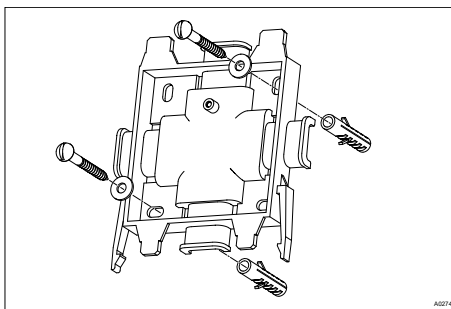

Fig. 2: Screwing on the wall/pipe bracket using washers

5. ➔ Screw on the wall/pipe bracket using the washers
6. ➔ Suspend the DULCOMETER® Compact Controller at the top in the wall/pipe bracket and push using light pressure at the bottom against the wall/pipe bracket. Then press upwards until the DULCOMETER® Compact Controller audibly snaps into position.

5.3.2 Pipe mounting

Mounting (mechanical)



Pipe diameter

Pipe diameter: 25 mm to 60 mm.

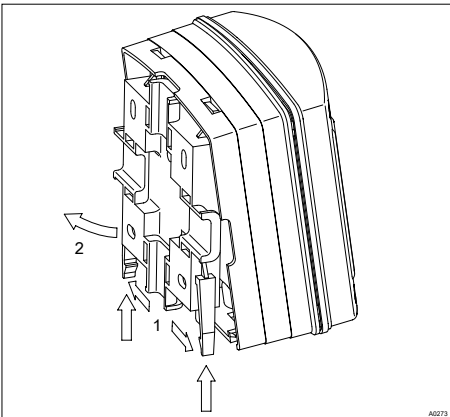

Fig. 3: Removing the wall/pipe bracket

1. ➔ Remove the wall/pipe bracket. Pull the two snap-hooks (1) outwards and push upwards
2. ➔ Fold out the wall/pipe bracket (2) and pull out in a downwards direction
3. ➔ Secure the wall/pipe bracket using cable ties (or pipe clips) to the pipe

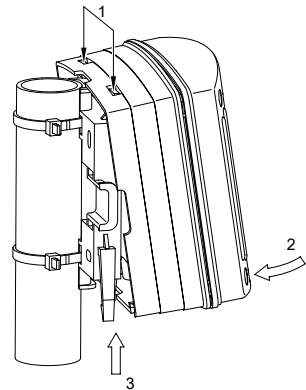

Fig. 4: Suspend and secure the DULCOMETER® Compact Controller

4. ➔ Suspend the DULCOMETER® Compact Controller at the top (1) in the wall/pipe bracket and push using light pressure at the bottom (2) against the wall/pipe bracket. Then press upwards (3) until the DULCOMETER® Compact Controller audibly snaps into position

5.3.3 Control panel mounting

Tab. 3: Mounting kit for control panel installation of the DULCOMETER® Compact Controller: Order number 1037273

Description	Quantity
Drilling template sheet 3872-4	1
PT screw (3.5 x 22)	3
Profile seals	2
Strain relief strip DF3/DF4	1
PT screw (3.5 x 10)	2
M4x30* fillister head screws	4

Individual parts packed in transparent bag / Mounting kit is not contained in the standard scope of supply

* The M4x30 fillister head screws should be used when mounting the control panel if the thickness of the control panel does not allow the top section of the controller housing to be securely attached with the screws used as standard.



CAUTION!

Material thickness of control panel

Possible consequence: Material damage

- The thickness of the material of the control panel should be at least 2 mm to ensure secure fixing



In the mounted state, the DULCOMETER® Compact Controller extends approx. 30 mm from the control panel.

Preparing the control panel

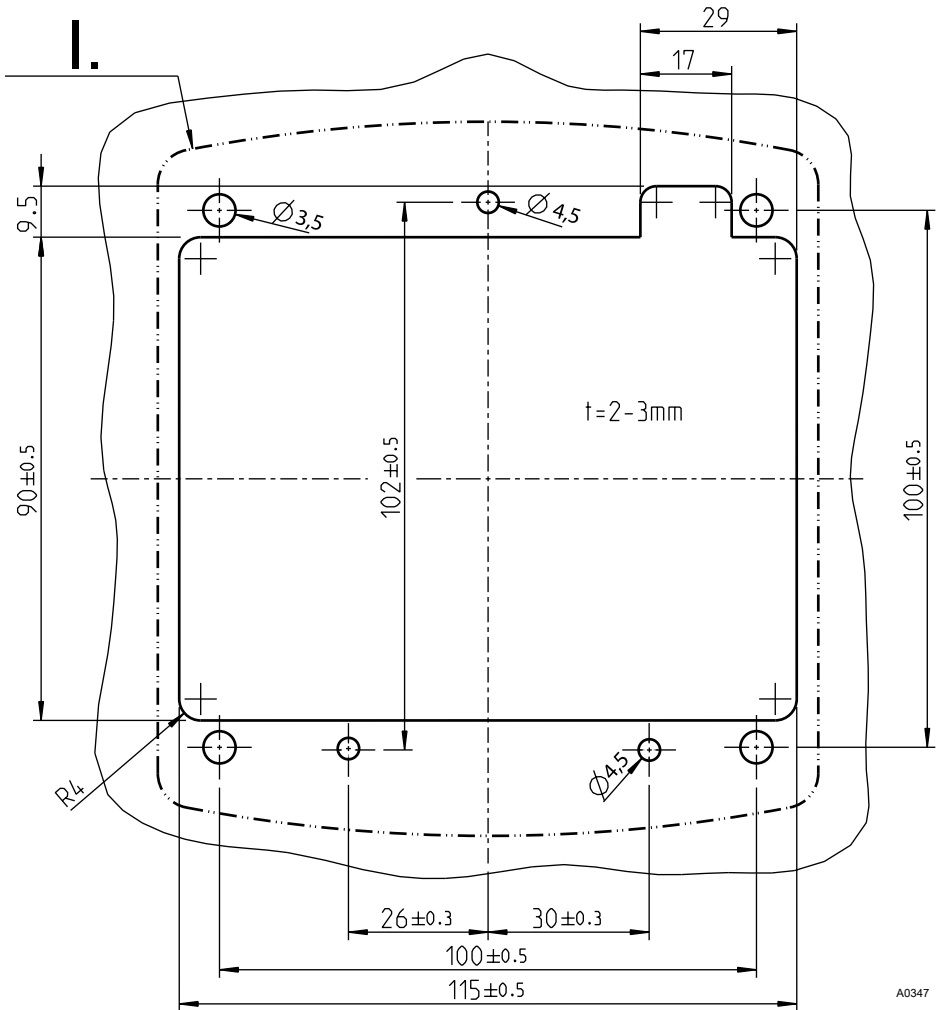

Fig. 5: The drawing is not to scale and is intended for information purposes only.

- I. Outline contour of the DULCOM-ETER® Compact Controller housing

1. ➔ Mark the exact position of the DULCOMETER® Compact Controller on the control panel using the drilling template

2. ➔



Core hole

Adhere to the 3.5 mm Ø as the core hole diameter for screwing in the fixing bolts.

Drill four holes for the bolts for the top section of the controller housing using a 3.5 mm Ø drill bit

3. ➔ Drill three holes for the bolts for the bottom section of the controller housing using a 4.5 mm Ø drill bit

4. ➔ Drill four holes using an 8 mm Ø drill bit and use a jigsaw to saw out the cut-out

⇒ Deburr all the edges.

Fitting the DULCOMETER® Compact Controller into the cut-out in the control panel

! NOTICE!

Ribbon cable base

The base for the ribbon cable is firmly soldered onto the PCB. The base cannot be removed. Open the base lock (3) to loosen the ribbon cable, see Fig. 6

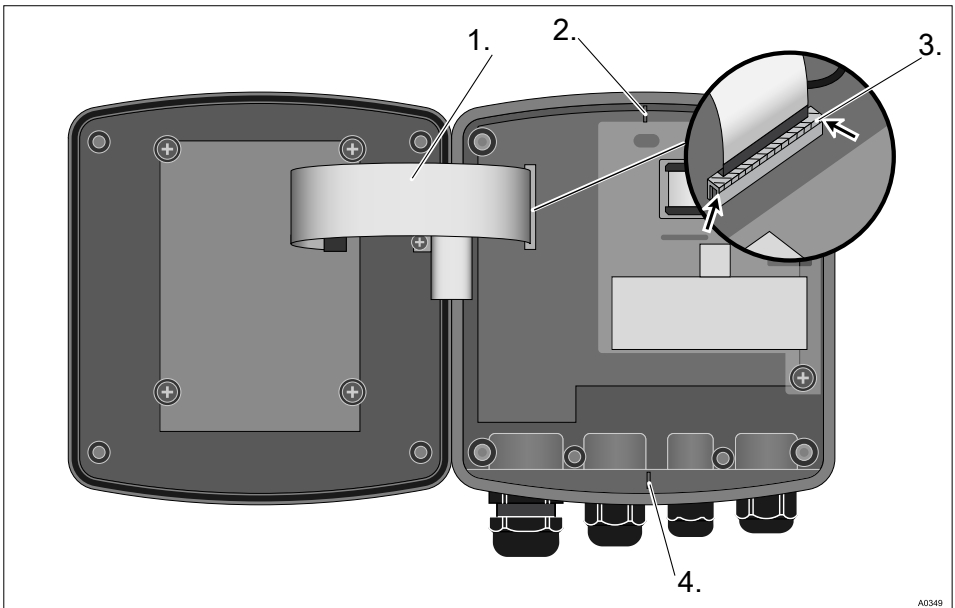

Fig. 6: Loosening the ribbon cable

1. ➤ Loosen four screws and open the DULCOMETER® Compact Controller
2. ➤ Open the right and left lock (3) (arrows) on the base and pull the ribbon cable (1) out of the base
3. ➤ Use pliers to break off the catches (2 and 4). These are not needed for control panel installation

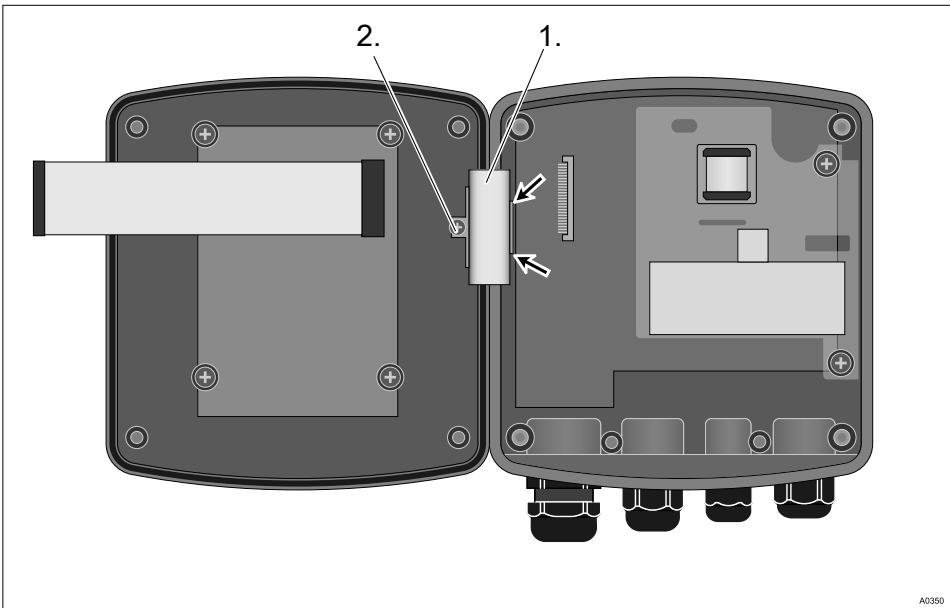
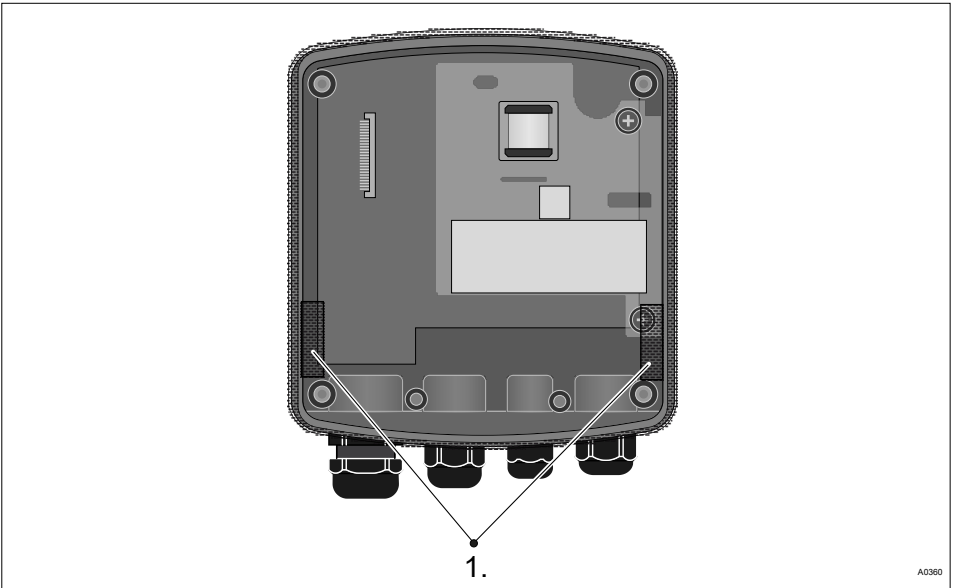

Fig. 7: Dismantling the hinge

4. ➔ Remove the screw (2), unclip the hinge (1) on the bottom section of the controller housing (arrows) and remove the hinge



A0360

Fig. 8: Fitting the profile seal on the bottom section of the controller housing

- 5.** ▶ Position the profile seal evenly around the upper edge of bottom section of the DULCOMETER® Compact Controller housing. The clips (1) must be arranged as shown in the figure
 - ⇨ Ensure that the profile seal evenly surrounds the upper edge of the housing.
- 6.** ▶ Insert the bottom section of the DULCOMETER® Compact Controller housing with the profile seal from behind into the cut-out and use three screws to secure it in place

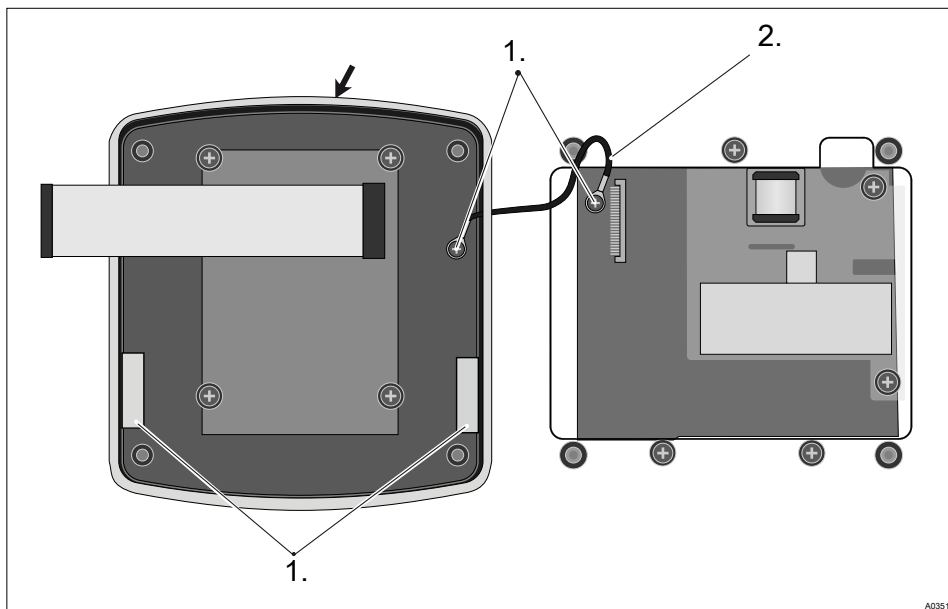

Fig. 9: Fitting the profile seal onto the top section of the controller housing

- 7.** ➤ Position the profile seal (arrow) evenly into the groove in the top section of the DULCOMETER® Compact Controller housing. The clips (3) must be arranged as shown in the figure
- 8.** ➤ Secure the strain relief (2) using two screws (1)

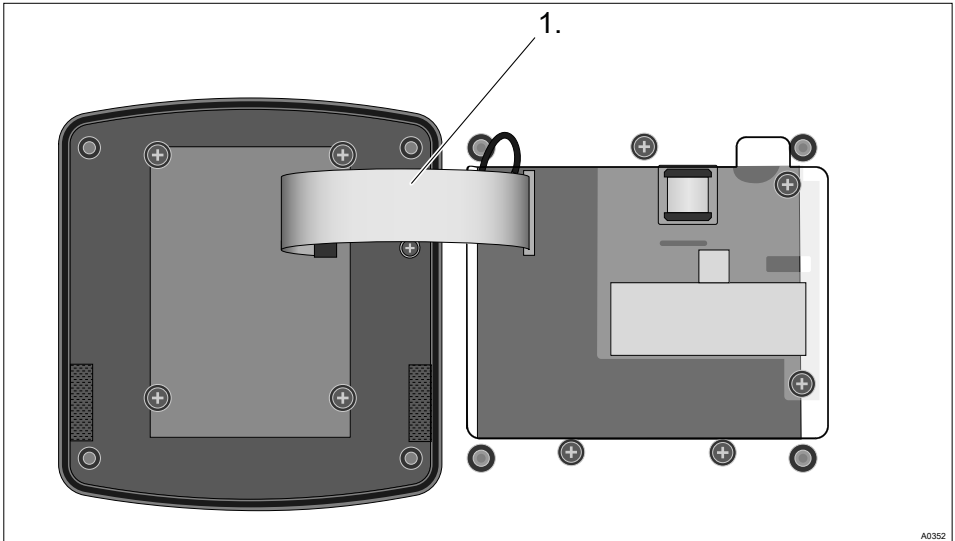

Fig. 10: Push and lock the ribbon cable in its base

- 9.** ▶ Push and lock the ribbon cable (1) in its base
- 10.** ▶ Screw the top section of the controller housing onto the bottom section of the DULCOMETER® Compact Controller housing
- 11.** ▶ Once again check that the profile seals are fitted properly
 - ⇒ IP 54 degree of protection can only be provided if the control panel is mounted correctly

5.4 Installation (electrical)



WARNING!

Live parts!

Possible consequence: Fatal or very serious injuries

- Measure: Disconnect the electrical power supply to the unit before opening the housing and secure to prevent unintentional reconnection.
- Disconnect damaged or defective devices or devices that have been tampered with and prevent unintended reconnection.
- The provision of a suitable isolating device (emergency-off switch, etc.) is the responsibility of the plant operator.



The signal leads of the controller may not be routed alongside cables prone to faults. These faults could lead to controller malfunctions.

5.4.1 Cable Cross-Sections and Cable End Sleeves

	Minimum cross-section	Maximum cross-section	Stripped insulation length
Without cable end sleeve	0.25 mm ²	1.5 mm ²	
Cable end sleeve without insulation	0.20 mm ²	1.0 mm ²	8 - 9 mm
Cable end sleeve with insulation	0.20 mm ²	1.0 mm ²	10 - 11 mm

5.4.2 Electrical connection of the conductivity sensor



CAUTION!

Length of the sensor cable

The sensor is supplied with a fixed cable or a measuring line.

Possible consequence: Slight or minor injuries. Material damage.

Set the length of the sensor cable in the *[INPUT]* menu so that the Pt 100 sensor measures the temperature correctly.

Ensure that all conductivity sensors connected to the controller have a shielded sensor cable.

5.4.3 Terminal diagram / wiring

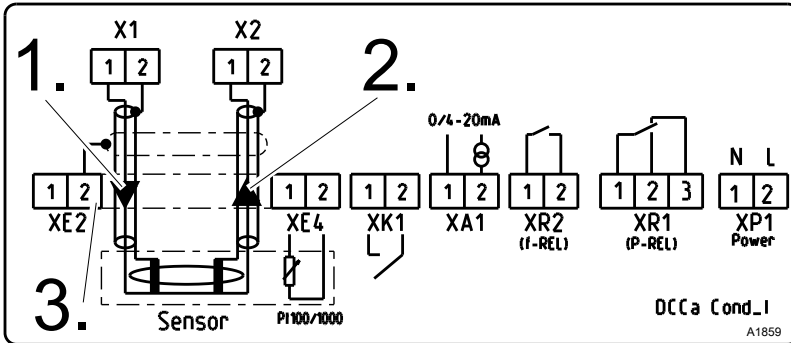

Fig. 11: Terminal diagram label for the Compact Controller

1. Control signal = Control signal to the transmission coil.
 2. Measuring signal = Measuring signal from the receiver coil.
 3. Cable shield connector to pin 2 of terminal XE2 as optional connection for outer cable shield when using ICT 2, ICT 5 or CLS 52 sensors.
- X1 Transmission coil connector
X2 Receiver coil connector



Please refer to the connector overviews on the following pages:

- ☞ Tab. 4 'Assignment of terminals to the respective sensors' on page 34
- ☞ Tab. 5 'Recommended cable diameter' on page 35
- ☞ Tab. 6 'Threaded connectors of cable openings' on page 36
- ☞ 'Terminal diagram' on page 38
- And also the chapter ☞ Chapter 6 'Sensor connector' on page 42
- And also the chapter ☞ Chapter 7.3 'Selecting the sensor type' on page 46



Terminal diagram label for the Compact Controller

The transmission coil shield must be connected to pin 2 of X1.

The receiver coil shield must be connected to pin 2 of X2.

Assembly and installation

Tab. 4: Assignment of terminals to the respective sensors

Terminal Pin	Sensor ICT 1 Conductor colours	Sensor ICT 2 Conductor colours	Sensor ICT 5 Conductor colours	Sensor CLS52 Conductor colours
X1.1 Transmission coil, signal, ▼	[ye] (yellow)	Coaxial inner conductor	Brown	Coaxial inner conductor
X1.2 Transmission coil, shield	[gn] (green)	[rd] (red, shield)	White	[rd] (red, shield)
X2.1 Receiver coil, signal, ▲	Coaxial inner conductor	Coaxial inner conductor	Pink	Coaxial inner conductor
X2.2 Receiver coil, shield ▲	Coaxial shield	[wh], (white, shield)	Cable shield, transparent	[wh], (white, shield)
XE2.2 Earth	n.n.	Cable shield	Cable shield, black	Cable shield
XE4.1 Pt100x	[bn] (brown)	[gn] (green)	Green	[gn] (green)
XE4.2 Pt100x	[wh] (white)	[wh] (white)	Yellow	[wh] (white)

Tab. 5: Recommended cable diameter

Identification of the cable	Diameter in mm
Mains cable	6.5
Temperature sensor cable	5.0
External control cable	4.5

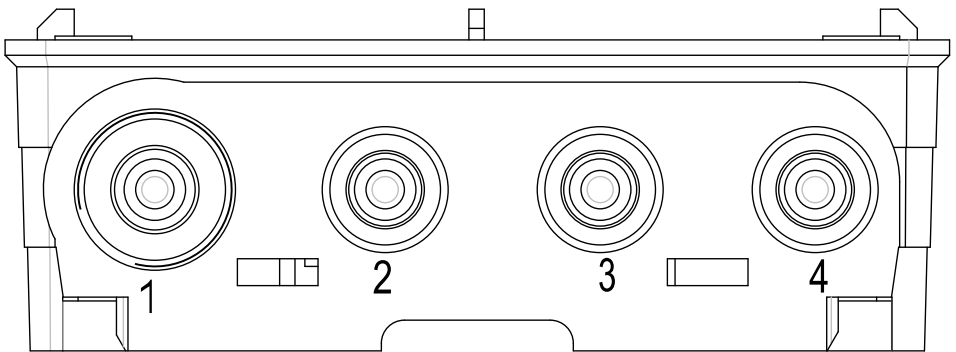

A0348

Fig. 12: Threaded connector number

Assembly and installation

Tab. 6: Threaded connectors of cable openings

Threaded connector no. size Fig. 12	Name	Terminal	Terminal no.	Pole	Function	Recommended cable Ø mm	Remark			
1 / M20	Sensor	X1	1	+	Measuring input		①			
			2	-						
		X2	1	+	Conductivity sensor with/without temperature sensor					
			2	-						
		XE4	1							
			2							
		XE2	2		Total shielding					
		① Pass the cable through the M20/2x5 mm multiple seal insert when using an external temperature sensor								
2 / M16	Standard signal output	XA1	1	+ 15V	e.g. recorder / actuator	4.5 mm	②			
			2	-						
	Contact input	XK1	1	+	Pause					
			2	-						
	Relay output	XR2	1		f-relay					
			2							
	② Pass 1 cable (4-wire) through the M16 / 2 x 4.5 mm multiple seal insert									
	3 / M16	Relay output	XR1	1	COM			Raise/lower solenoid valve	5 mm	③
2				NO						

Threaded connector no. size Fig. 12	Name	Terminal	Terminal no.	Pole	Function	Recommended cable Ø mm	Remark
	Relay output	XR1	1	COM	Limit value relay	5 mm	
			2	NO			
	Relay output	XR1	1	COM	Alarm relay	5 mm	
			3	NC			
③ Pass cable through M16 single seal insert							
4 / M16	Mains connection	XP1	1	N	90 ... 253 V effective	6.5 mm	④
			2	L			
④ Pass cable through M16 single seal insert							

Terminal diagram

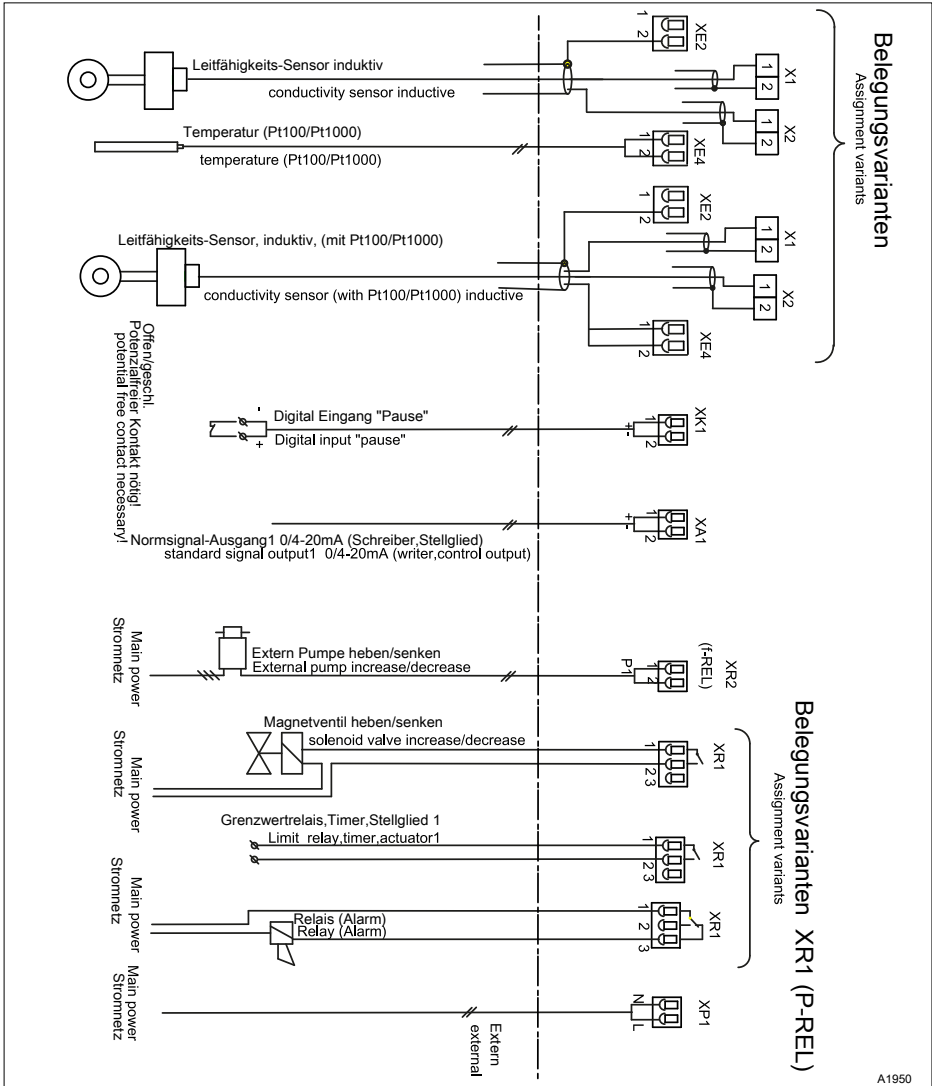

Fig. 13: Terminal diagram

5.4.4 Installation (electrical)



The cable must be routed in a site-provided cable duct to ensure strain relief

1. ➤ Undo the four housing screws
2. ➤ Slightly lift the controller housing top section forwards and fold it to the left

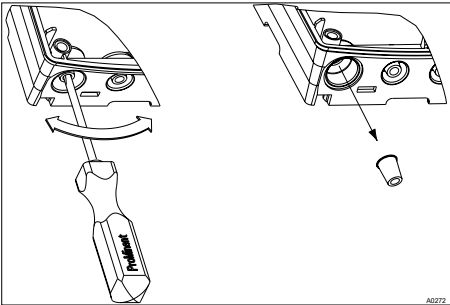

Fig. 14: Punch out threaded holes

3. ➤



*Large threaded connection
(M 20 x 1.5)*

*Small threaded connection
(M 16 x 1.5)*

Punch out as many threaded connections on the bottom side of the controller housing bottom section as required

4. ➤ Guide the cable into the respective reducing inserts.
5. ➤ Insert the reducing inserts into the threaded connectors
6. ➤ Guide the cable into the controller.
7. ➤ Connect the cable as indicated in the terminal diagram
8. ➤ Screw the required threaded connections in and tighten
9. ➤ Tighten the clamping nuts of the threaded connections so that they are properly sealed
10. ➤ Click the controller housing top section on to the controller housing bottom section
11. ➤ Manually tighten the housing screws
12. ➤ Once again check the seating of the seal. Only if the mounting is correct, is protection class IP 67 (wall/pipe mounting) or IP 54 (control panel mounting) achieved

5.5 Switching of inductive loads



If you connect an inductive load, i.e. a consumer which uses a coil (e.g. an alpha motorised pump), then you must protect your controller with a protective circuit. If in doubt, consult an electrical technician for advice.

The RC member protective circuit is a simple, but nevertheless very effective, circuit. This circuit is also referred to as a snubber or Boucherot member. It is primarily used to protect switching contacts.

When switching off, the connection in series of a resistor and capacitor means that the current can be dissipated in a damped oscillation.

Also when switching on, the resistor acts as a current limiter for the capacitor charging process. The RC member protective circuit is highly suitable for AC voltage supplies.

The magnitude of the resistance R of the RC member is determined according to the following equation:

$$R = U / I_L$$

(Where U = Voltage across the load and I_L = current through the load)

The magnitude of the capacitor is determined using the following equation:

**Units: R = Ohm; U = Volt; I_L = Ampere;
C = μ F**

$$C = k * I_L$$

k=0,1...2 (dependent on the application).

Only use capacitors of class X2.

**Units: R = Ohm; U = Volt; I_L = Ampere;
C = μ F**



If consumers are connected which have a high starting current (e.g. plug-in, switched mains power supplies), then a means of limiting the starting current must be provided.

The switching-off process can be investigated and documented using an oscilloscope. The voltage peak at the switch contact depends on the selected RC combination.

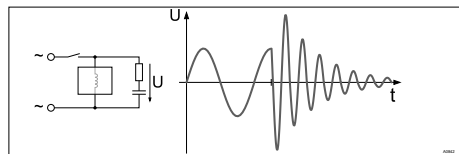

Fig. 15: Switching-off process shown on the oscillogram.

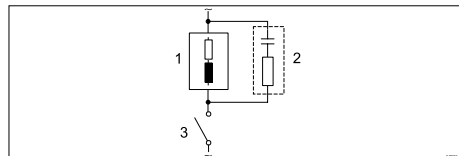

Fig. 16: RC protective circuit for the relay contacts

Typical AC current application with an inductive load:

- 1) Load (e.g. alpha motor-driven pump)
- 2) RC-protective circuit
 - Typical RC protective circuit at 230 V AC:
 - Capacitor [$0.22\mu F/X2$]
 - Resistance [$100\ \Omega / 1\ W$] (metal oxide (pulse resistant))
- 3) Relay contact (XR1, XR2, XR3)

6 Sensor connector

- **User qualification, sensor connector:**
trained and qualified personnel
↳ Chapter 3.4 'User qualification'
on page 15



Shielded sensor cable

All conductivity sensors connected to the controller require shielded sensor cables.

Many conductivity sensors have total shielding. The conductivity sensors ICT 1 have an internally connected total shielding.

Connect the sensor in accordance with the terminal diagram.



Ensure that the controller is not electrically connected

Ensure that the controller is not electrically connected when the sensor is installed, as the controller could otherwise be damaged.



Selection of the connected sensor

All of the sensor-dependent settings are reset to the [DEFAULT] values of the controller when changing the sensor connected.

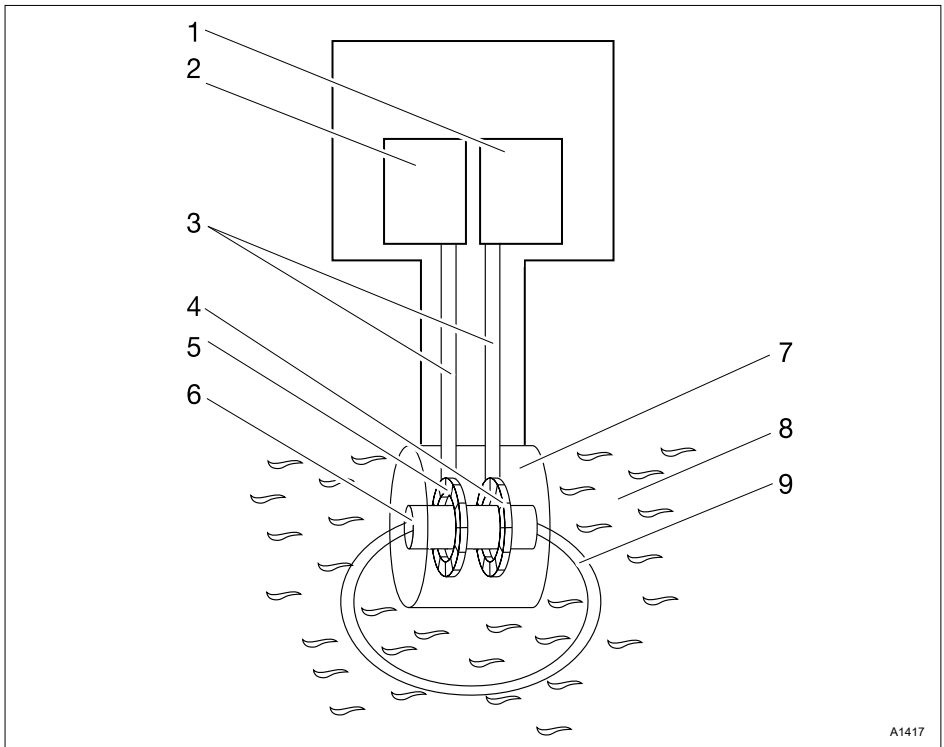

A1417

Fig. 17: Measuring principle

- | | |
|-----------------------------------|--------------------|
| 1. Receiver and signal processing | 6. Hole |
| 2. Oscillator | 7. Sensor head |
| 3. Cable | 8. Sample water |
| 4. Receiver coil | 9. Induced current |
| 5. Transmission coil | |

Sensor connector

Sensor	Connector	Cell constant Cell constant (1/cm)	T-correction element	Max. temp. (°C)	Measuring range κ min (Unit)	Measuring range κ max (Unit)
ICT 1	Fixed cable, 7 m	$8.5 \text{ cm}^{-1} \pm 5\%$	Pt100	70 °C	200 $\mu\text{S/cm}$	1000 mS/cm
ICT 2	Fixed cable, 5 m	1.98 cm^{-1}	Pt100	125 °C	5 $\mu\text{S/cm}$	2000 mS/cm
ICT 5	Fixed cable, 10 m	6.25 cm^{-1}	Pt1000	80 °C	200 $\mu\text{S/cm}$	2000 mS/cm
MANUAL	☞ Chapter 9.5 'Setting the [MANUAL] sensor in the [INPUT] menu' on page 77				0 $\mu\text{S/cm}$	2000 S/cm
E+H CLS52	Fixed cable, 20 m	$k = 5.9 \text{ cm}^{-1}$	Pt100	125 °C	50 $\mu\text{S/cm}$	2000 mS/cm

Conductivity sensors from external companies

Sensor = [MANUAL]. This setting is selected with conductivity sensors from external companies, refer in this respect to ☞ Chapter 9.5 'Setting the [MANUAL] sensor in the [INPUT] menu' on page 77

Monitoring of the sensor / measuring range

- When no sensor is connected,
- or the sensor cable is not connected properly,
- or the sensor cable is broken,
- or the sensor is not immersed in the measuring fluid,

the error message [Test ?] appears, ([test] = means 'sensor'),

7 Commissioning

- **User qualification:** trained user, see  *Chapter 3.4 'User qualification' on page 15*



WARNING!

Sensor run-in periods

This can result in dangerous incorrect metering



- Correct measuring and metering is only possible if the sensor is working perfectly
- Refer to the operating instructions for the sensor
- Calibrate the sensor after commissioning

Following mechanical and electrical installation, integrate the controller into the measuring point.

7.1 Initial commissioning

The controller is in STOP mode when the controller is first switched on.

Setting the auto-ranging profile

1.  Select the inductive conductivity sensor used.
2.  Enter the actual sensor cable length.
 - ⇒ Subsequently enter the control setting and the setting for the different parameters dependent on the process to be measured.
3.  Set the auto-ranging profile when connecting external sensors, *[INPUT > SENSOR > MANUAL]*.

7.2 Setting the control during commissioning

! NOTICE!

Reset to factory settings

When switching over the metering direction, all actuators in the controller are reset to the factory settings for the selected metering direction.

For safety reasons, all the actuators are deactivated. The basic load is reset to 0 %. All parameters relating to the actuator, are reset to the factory setting.

Reset all the parameters that relate to the actuator.

The controller only controls *'one-way'*. Only one position or one negative control variable can be calculated. The direction of the control variable is set in the *'PUMP'* menu. There is no dead zone. In this sense, the control cannot be *'deactivated'* (except with *'STOP'* or *'PAUSE'*).

The value of the P-proportion of the control (X_p) is specified for the controller in the unit of the corresponding measured variable.

With pure P-control and a difference between the set and actual values, which corresponds to the X_p value, the calculated control variable is +100% (at the *'raise'* setting) and -100% (at the *'lower'* setting).

7.3 Selecting the sensor type



Entering the cable length

The precise entry of the cable length is important with longer cable lengths.

The Pt100 measurement is corrected by the cable resistance that comes from the cable length entered. The correction for a cable with a cross-sectional area of 0.25 mm² is 3.5 °C every 10 m of cable length.

Use of fixed-cable ProMinent sensors

1. ➤ Press **MENU** and use the **▼** or **▲** keys to move the cursor to the **[INPUT]** menu item and confirm the selection with **OK**.
2. ➤ Use the **▼** or **▲** keys to move the cursor to the **[SENSOR]** menu item and confirm with **OK**.
3. ➤ Use the **▼** or **▲** keys to select the sensor used and confirm with **OK**.

Enter the cable length used:



Adjusting the fixed cable length

*If you are using a conductivity sensor with a fixed cable and have to shorten the length of the cable, adjust the actual cable length in the menu under **[LEN]**.*

4. ➤ Use the **▼** or **▲** keys to select the menu item **[LEN]** and confirm with **OK**.
5. ➤ Use the **↔**, **▼** or **▲** keys to adjust the entry for the cable length and confirm with **OK**.
6. ➤ Press **ESC** twice to return to the continuous display.

Using external sensors

1. ➤ Press **MENU** and use the **▼** or **▲** keys to move the cursor to the **[INPUT]** menu item and confirm the selection with **OK**.
2. ➤ Use the **▼** or **▲** keys to move the cursor to the **[SENSOR]** menu item and confirm with **OK**.
3. ➤ Use the **▼** or **▲** keys to move the cursor to the **[MANUAL]** menu item and confirm with **OK**.
 - ⇒ The question **[ARE YOU SURE]** appears
4. ➤ Use the **▼** or **▲** keys to select **[YES]** and confirm with **OK** if you wish to set the **[SENSOR]** entry to **[MANUAL]**.

Enter the cable length used:

5. ➤ Use the **▼** or **▲** keys to select the menu item **[LEN]** and confirm with **OK**.

Selecting the auto-ranging profile

6. ➤ Use the **▼** or **▲** keys to select the menu item **[PROFILE]** and confirm with **OK**.
7. ➤ Use the **▼** or **▲** keys to adjust the **[PROFILE]** entry and confirm with **OK**.

See,  *Chapter 9.5 'Setting the [MANUAL] sensor in the [INPUT] menu' on page 77.*



Try another profile if the selected [PROFILE] entry does not deliver the required result.

8. ➤ Press **ESC** twice to return to the continuous display.

7.4 Temperature compensation and reference temperature

Adjust the temperature compensation and reference temperature for correct display of the inductive conductivity [*ConI*] and resistance [*RES*].

Non-adjustable values are specified by the controller for the display of [*TDS*] and [*SAL*].

Tab. 7: Temperature compensation

Variable	Description	Type of temperature compensation	Range	Reference temperature (°C)
Specific conductivity / Electrical resistance	off	none		
	lin	linear, 0 ... 9.99 %/K	- 20 °C...150 °C	15 °C ... 30 °C adjustable
	nLF	non-linear for natural water (DIN EN 27888)	0 °C...35 °C	20 °C or 25 °C selectable
		extended nLF function	35 °C ... 120 °C	20 °C or 25 °C selectable
TDS	---	linear	0°C...40°C	25°C, fixed
SAL	---	non-linear according to PSS-78	0°C...35°C	15°C, fixed according to PSS-78

The inductive conductivity measured at the fluid temperature is converted to the reference temperature $[TREF]$.



Changing the reference temperature

The temperature coefficient $[TCOEFF]$ has to be recalibrated if the reference temperature $[TREF]$ is changed.

Adjustable process for temperature compensation

- *[off]*
 - Temperature compensation is switched off. It is measured based on the set reference temperature.
- *[lin]*
 - Linear temperature compensation, see [Chapter 10.5 'Temperature correction variable'](#) on page 92, for the temperature range permitted for the sensors. The reference temperature $[TREF]$ can be set between 15 °C and 30 °C.
- *[nLF]*
 - Non-linear temperature compensation according to DIN EN 27888 for natural water, between 0 °C ... 35 °C. The reference temperature $[TREF]$ can be switched, 20 °C / 25 °C.

8 Operating diagram

8.1 Overview of equipment/Operating elements

- **User qualification:** instructed user, see  Chapter 3.4 'User qualification' on page 15

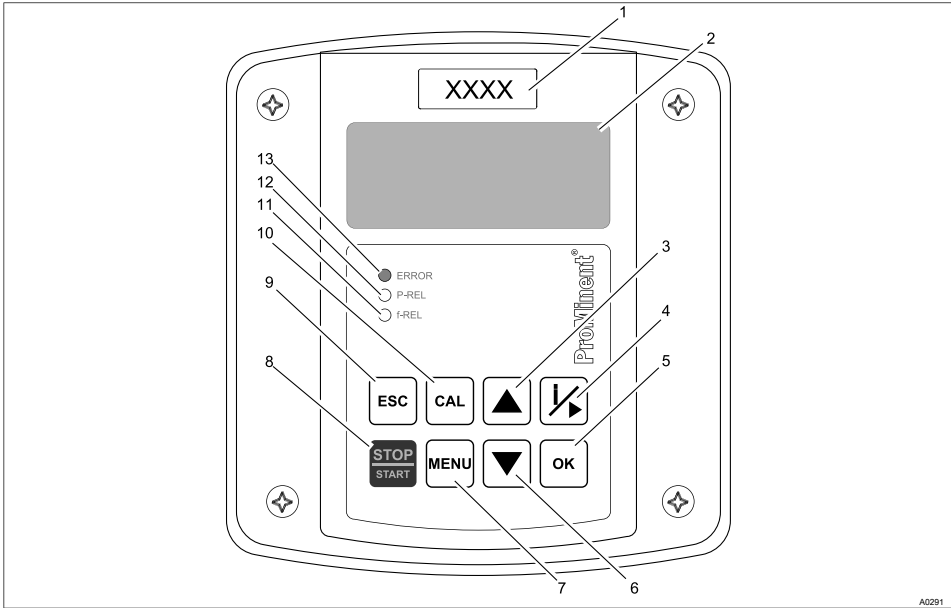

Fig. 18: Overview of equipment/Operating elements

Function	Description
1st respective measured variable	Affix the measured variable label here
2. LCD display	
3. UP key	To increase a displayed numerical value and move up in the operating menu
4. INFO/RIGHT key	Opens the information menu or moves the cursor one place to the right
5. OK key	To apply, confirm or save a displayed value or status or To confirm an alarm

Function	Description
6. DOWN key	To decrease a displayed numerical value and move down in the operating menu
7. MENU key	To access the controller's operating menu
8. STOP/START key	Starts and stops the control and metering function
9. ESC key	Moves one level back in the operating menu, without storing or changing entries or values Switches the measured variables in the continuous display.
10. CAL key	To access the calibration selection menu (cell constant and temperature coefficient) and navigate within the calibration menu.
11. f-REL LED	Shows the activated state of the f-relay
12. P-REL LED	Shows the activated state of the P-relay
13. ERROR LED	Indicates a controller error state. A text message is displayed simultaneously in the LCD display of the continuous display

8.2 Entering values

Described by the example of entering set-points in the Control menu.

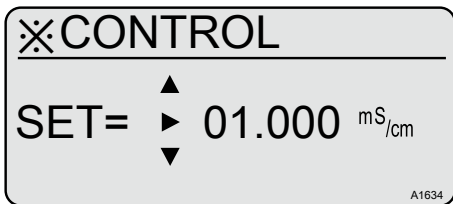

Fig. 19: Entering values

1. Use to select each position of the value to be entered.



You can also select and change the unit of the value to be entered.

2. Enter the values using the and keys
3. : The value entered is transferred to the memory.
4. : Cancelling the input of values without saving the entered value. The original value is retained.

8.3 Adjusting display contrast

If the DULCOMETER® Compact Controller is set to *'continuous display'*, you can set the contrast of the LCD-display. By pressing the ▲ key you can adjust the LCD display contrast so it is darker. By pressing the ▼ key you can adjust the LCD display contrast so it is lighter. Here each key press represents a contrast level. I.e. the key must be pressed once for each contrast level.

8.4 Continuous display

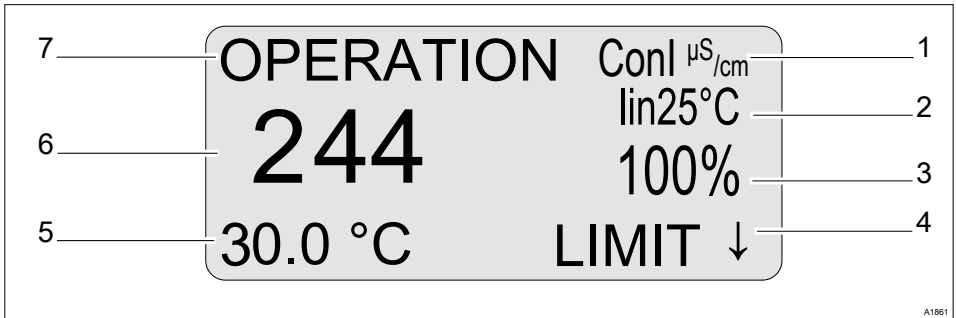

Fig. 20: Continuous display

- | | |
|--|--|
| <ul style="list-style-type: none"> 1 Measured variable (switch using <i>[ESC]</i>): the following are possible: <i>[Conl]</i>, <i>[RES]</i>, <i>[TDS]</i> and <i>[SAL]</i> 2 Reference temperature or temperature compensation 3 Control variable 4 Possible error text: for example <i>[Limit ↓]</i> (direction of limit value transgression e.g. value below the limit in this case) | <ul style="list-style-type: none"> 5 Temperature (correction variable) 6 Measured value (actual value) 7 Operating status |
|--|--|

The bottom line displays the current measuring temperature and/or a temperature manually entered. The temperature display cannot be switched off.

The temperature (measuring temperature or reference temperature) is needed to calculate all measured variables, which is why the second line of the continuous display therefore displays information about temperature compensation and the reference temperature.

The setpoint is displayed in the Information menu.

Switching between measured variables

Use the **[ESC]** key to switch between the controller's measured variables *[Conl]*, *[RES]*, *[TDS]* and *[SAL]* in the continuous display.

Depending on the measured variable set, the settings of variables are changed or the variables are hidden completely in the *[INPUT > TCOMP]* menu and in the *[LIMIT]* menu.

8.5 Information display

The most important parameters for each first-level menu item are displayed in the information display.

Use **↵** to access the information display from the continuous display. Pressing **↵** again calls up the next information display. Pressing **ESC** calls up the continuous display again.

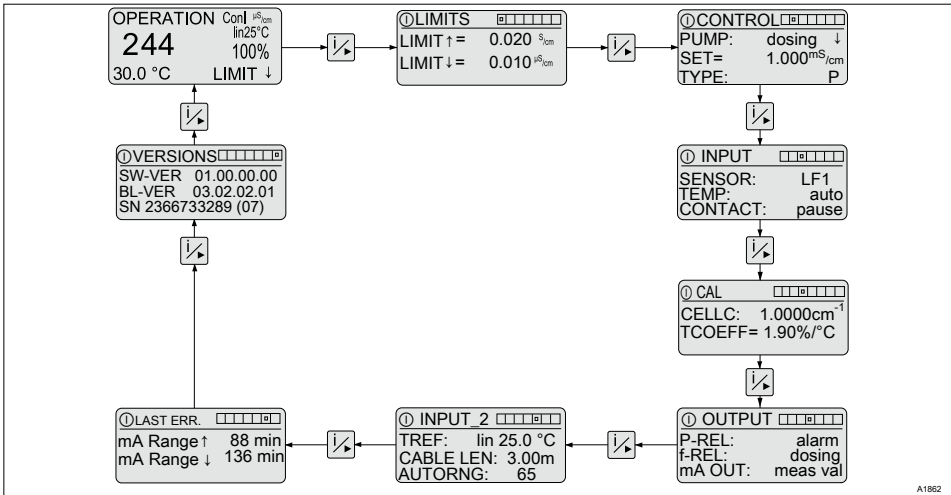

Fig. 21: Information display

Use **OK** to move from the information display currently shown to the selection menu for this information display.

Use **ESC** to move directly back to the information display.

8.6 Password

Access to the setting menu can be restricted by a password. The controller is delivered with the password '5000'. The controller is set up with the pre-set password '5000' so that access is possible to all menus.

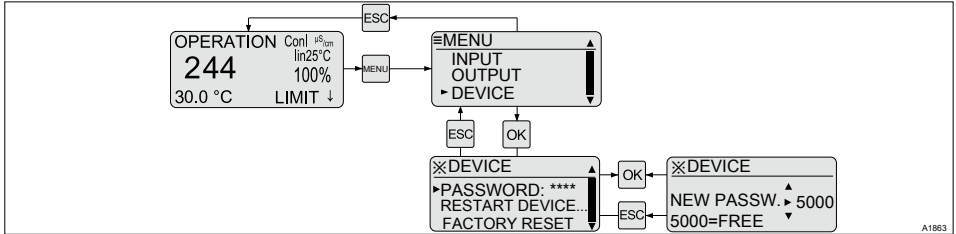

Fig. 22: Setting the password

Password	Possible values			
Factory setting	Increment	Lower value	Upper value	Remark
5000	1	0000	9999	5000 = [FREE]

9 Operating menus

- **User qualification:** instructed user ↪ Chapter 3.4 'User qualification' on page 15

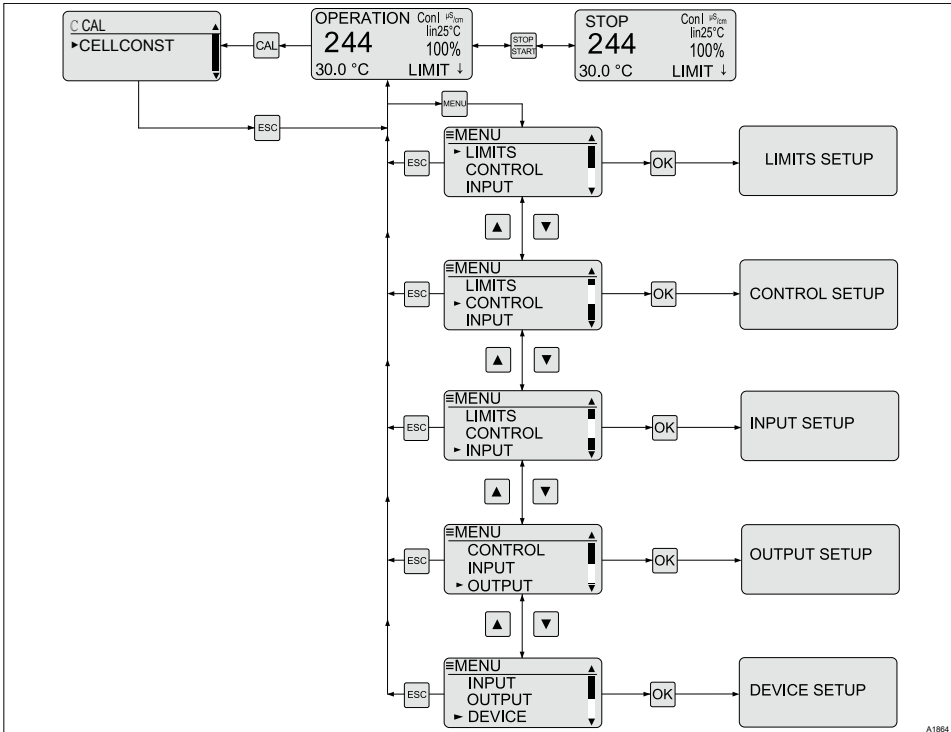

Fig. 23: Overview of the first level menu.

9.1 Calibrating [CAL] the conductivity sensor

The following calibration functions are available depending on the type of sensor:

- Calibrate the cell constant
- Calibrate the temperature coefficient
- Calibrate the zero point



Correct sensor operation

- Correct measurement and metering is only possible if the sensor is working perfectly.
- Refer to the sensor's operating instructions.

**Incorrect calibration**

An error message 'ERR' appears if the result of the calibration lies outside the specified tolerance limits. In this case, the current calibration is not applied.

Check the prerequisites for calibration and clear the error. Then repeat calibration.

If the calibration is again incorrect, refer to the information provided in the sensor operating instructions.

During calibration, the controller sets the control outputs to '0'. Exception: If a basic load or a manual control variable has been set. This remains active. The mA standard signal output is frozen.

When calibration has been completed successfully, all the error checks relating to the measured value are restarted. The controller saves the data determined for the cell constant and temperature coefficient when calibration is successful.

The conductivity sensors can be calibrated using 3 different methods. The cell constant is adjusted directly or indirectly with all methods:

- Calibration compared to a reference solution
- Calibration compared to a reference measurement (e.g. manual measuring device)
- Calibration by entering a precisely known or determined cell constant

9.1.1 Calibration of the cell constant

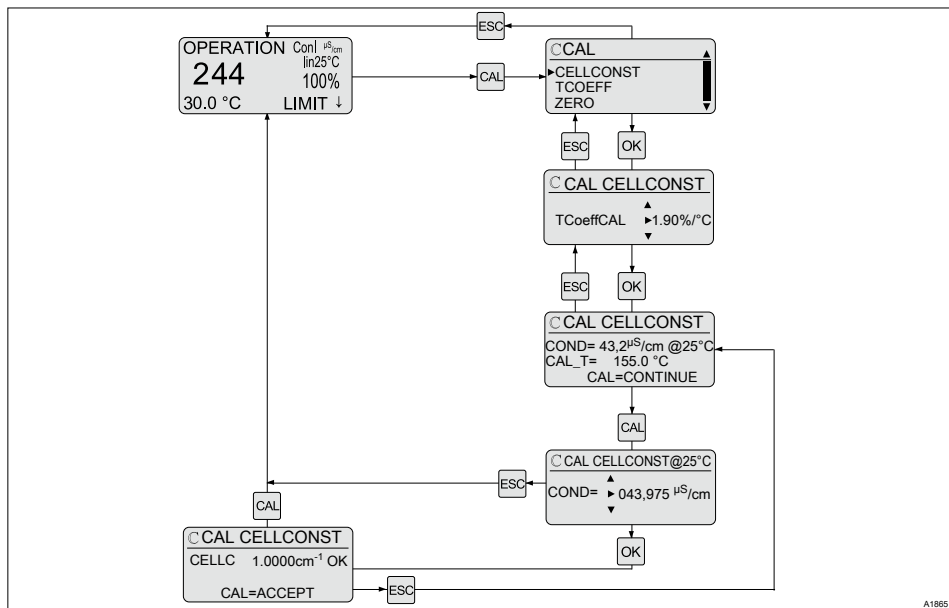

Fig. 24: Calibration of the cell constant

Calibration compared to a calibration solution

1. ▶ Press **CAL** and use the **▲** or **▼** key to move the cursor to *[CELLCONST]* and confirm with **OK**.
2. ▶ Enter the temperature coefficient of the calibration solution.



The temperature coefficient of the calibration solution is specified on the storage tank for the calibration solution.

Confirm with **OK**.

3. ▶ Now dip the sensor into the calibration solution and gently move the sensor.
4. ▶ Wait until the conductivity and temperature measured value has stabilised.
Press **CAL**.
⇒ The conductivity value measured is displayed.
5. ▶ Now use the **↵**, **▲** or **▼** keys to set the conductivity value measured, in accordance with the conductivity value specified on the calibration solution.
⇒ If calibration has been completed successfully, the controller stores the determined values for the cell constant and the error checks relating to the measured value are restarted. The numerical setting range of the cell constant is not limited.
6. ▶ Press **ESC** twice to return to the continuous display.

Calibration compared with a reference measurement (e.g. manual measuring device)



Temperature coefficient of the measuring solution

The temperature coefficient of the measuring solution has to be known.

1. ➔ Press **CAL**, leaving the sensor in the application in which the sensor is fitted.
2. ➔ Use **▲** or **▼** key to move the cursor to **[CELLCONST]** and confirm with **OK**.
3. ➔ Enter the temperature coefficient of the measuring solution.
Confirm with **OK**.
4. ➔ Press **CAL**.
⇒ The conductivity value measured is displayed.
5. ➔ Now use the **↵**, **▲** or **▼** keys to enter the conductivity value displayed, in accordance with the reference value measured.
⇒ If calibration has been completed successfully, the controller stores the determined values for the cell constant and the error checks relating to the measured value are restarted. The numerical setting range of the cell constant is not limited.
6. ➔ Press **ESC** twice to return to the continuous display.

Calibration by entering a precisely known cell constant

1. ➔ Press **MEN** and use the **▲** or **▼** key to move the cursor to **[INPUT]**
Confirm with **OK**.
2. ➔ Use the **▲** or **▼** key to move the cursor to **[CELLC]**.
Confirm with **OK**.
3. ➔ Now use the **↵**, **▲** or **▼** keys to adjust the precisely known or previously determined cell constant.
Confirm with **OK**.
4. ➔ Press **ESC** twice to return to the continuous display.

Tab. 8: Sensor status

Display	Meaning	Status
[OK]	In order	Cell constant = 0.005 / 99.9
[WRN]	Warning	none
[ERR]	Error	Cell constant < 0.005 or cell constant > 100

9.1.2 Calibration of the temperature coefficient



Conductivity sensors with temperature element

You can only calibrate the temperature coefficient with conductivity sensors with a temperature element, because it is impossible to calculate the temperature coefficient without measuring the temperature.



Temperature change

It is recommended that the temperature is changed by no more than 0.5 °C per minute, or with a temperature change of e.g. 10 °C you will need to wait for a minimum of 20 minutes before calibration.

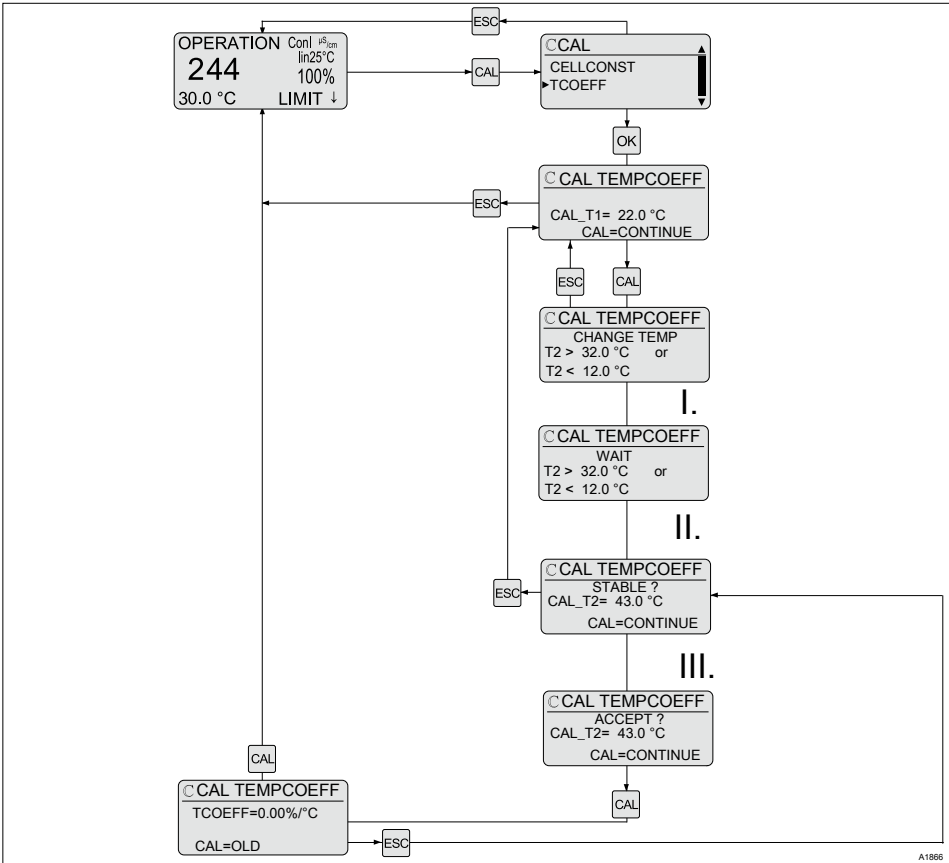

Fig. 25: Calibration of the temperature coefficient

- I. If the temperature change is greater than 2°C, the message changes to [WAIT]
- II. If the temperature is within the specified range, the message changes to [STABLE ?]
- III. When a stable final temperature has been reached, the message changes to [ACCEPT?]. Calibration can now be terminated manually.

1. ➤ Calibrate at the first calibration temperature; this calibration temperature should be close to the selected reference temperature.
2. ➤ Press *[CAL]* to accept the first calibration point. At the same time the temperature ranges for the second temperature value are given.
3. ➤ Important note: *[CHANGE TEMP]*, now immerse the sensor in the same liquid with the second calibration temperature (minimum temperature difference $\pm 10\text{ }^{\circ}\text{C}$)
4. ➤ If the measured temperature has changed by more than $2\text{ }^{\circ}\text{C}$, *[WAIT]* is displayed.
5. ➤ If the temperature has changed by more than $10\text{ }^{\circ}\text{C}$, *[STABLE?]* is displayed, and you can now terminate calibration if the displayed temperature value no longer changes (fluctuation $< 0.3\%$ of the value displayed). To do so, press *[CAL]*.
6. ➤ When the Maximum/Minimum temperature has been reached, *[ACCEPT?]* is displayed
 - ⇒ You can now terminate calibration. To do so, press *[CAL]*.



This process may take 10 ... 20 minutes depending on the type of sensor.

7. ➤ Use *[CAL]* to accept the temperature coefficient or *[ESC]* to discard it

Sensor status

Display	Meaning	Status
<i>[OK]</i>	In order	$[\Delta T_{cal}] > 20\text{ }^{\circ}\text{C}$
<i>[WRN]</i>	Warning	$[\Delta T_{cal}] = 10\text{ }^{\circ}\text{C} \dots 20\text{ }^{\circ}\text{C}$
<i>[ERR]</i>	Error	$[\Delta T_{cal}] < 10\text{ }^{\circ}\text{C}$
$[\Delta T_{cal}] =$ Temperature difference of the calibration liquids		

9.1.3 Calibrating the zero point



Dry the sensor and keep it free from electromagnetic fields

If the zero point of the sensor is to be calibrated, it is essential that the sensor is removed, rinsed and dried before calibration. No electromagnetic fields may influence the sensor as these electromagnetic fields could distort calibration. Keep devices that transmit radiation away from the sensor, such as mobile phones, WLAN routers, sources of high voltage, transformers etc.

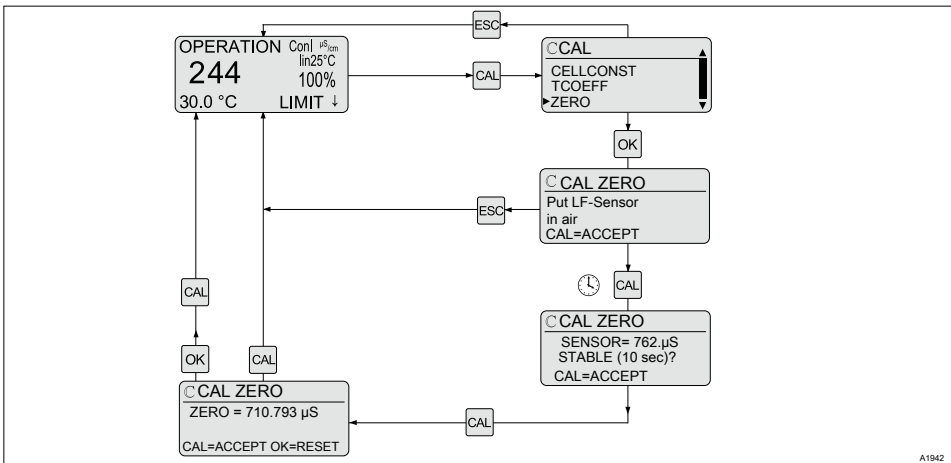

Fig. 26: Calibrating the zero point / The [CAL] [ZERO] default value corresponds to the default value of the sensor selected.

Tab. 9: Zero point calibration limits

Sensor	Value
ICT 1	65 µS
ICT 2	4 µS
ICT 5	30 µS
CLS52	4 µS
Manual	50 µS

Calibrating the zero point

1. ➤ Press **CAL**, remove the sensor from the application in which it is fitted.
2. ➤ Rinse the sensor with clean water and dry it.
3. ➤ Use the **▲** or **▼** key to move the cursor to *[ZERO]* and confirm with **OK**.
4. ➤ Hold the sensor in the air.
Press **CAL**.
5. ➤ Wait for the process *[WAIT ...]*.
⇒ *[STABLE (10 sec)?]* = The value displayed needs to be displayed stably for longer than 10 seconds. (Fluctuation < 0.5% of the displayed value).
6. ➤ Press **CAL**.
7. ➤ Press **CAL**, or
Press **OK** if you wish to use the *[ZERO]* default value and then press **CAL**.
⇒ The new value for the zero point is carried over into the memory and the controller shows the continuous display again.

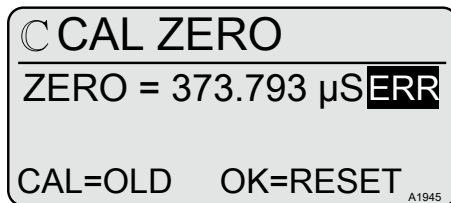

Fig. 27: Display of incorrect calibration.

8. ➤ In the event of incorrect calibration, press **CAL** to retain the old calibration value and press **OK** to use the factory settings.

9.2 Setting limit values [LIMITS]

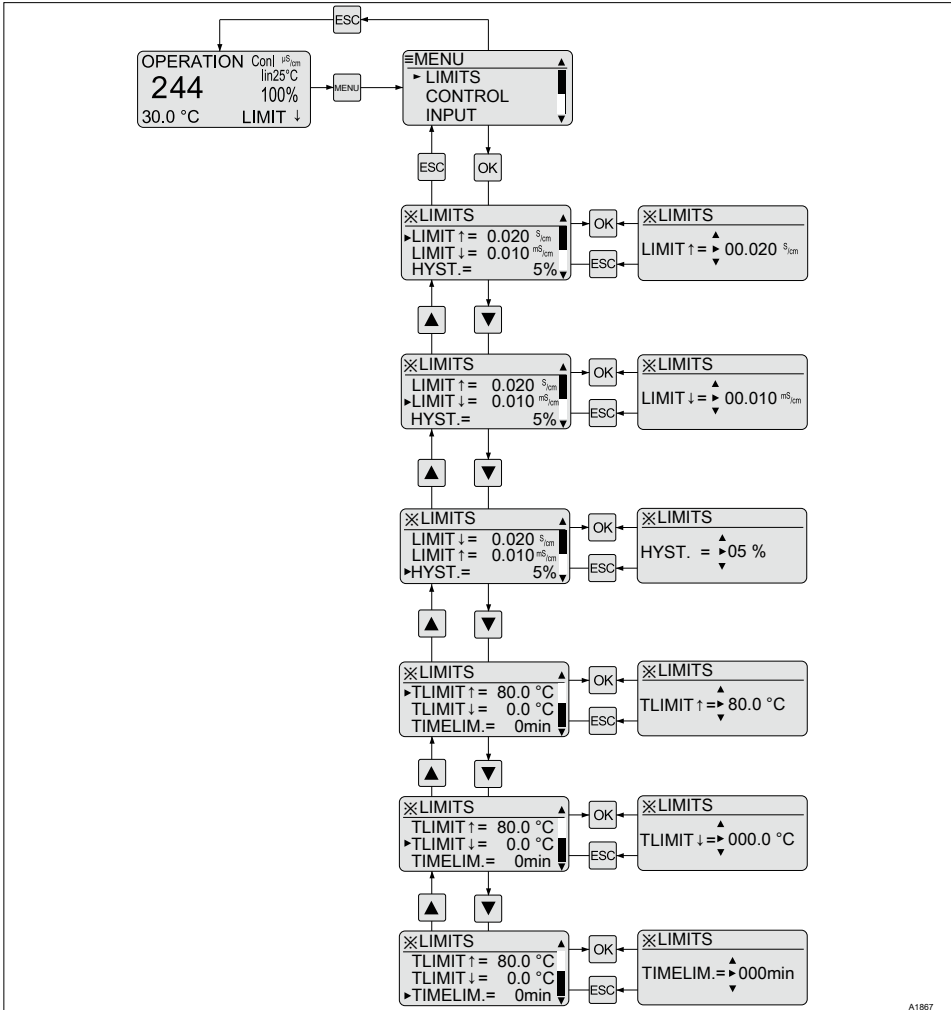

Fig. 28: Setting limit values [LIMITS]

Setting		Possible values			
Display	Starting value	Increment	Lower value	Upper value	Remark
[LIMIT ↑]	0.02 S/cm	0,001	0.000 uS/cm	2.000 S/cm	Upper limit value
[LIMIT ↓]	0.01mS/cm	0,001	0.000 uS/cm	2.000 S/cm	Lower limit value
[HYST.]	5 %	1 %	1 %	20 %	Hysteresis of limit values
[TLIMIT ↑] °C	30.0 °C	0.1 °C	0.0 °C	150.0 °C	Upper limit value correction value °C
[TLIMIT ↓] °C	10.0 °C	0.1 °C	0.0 °C	150.0 °C	Lower limit value correction value °C
[TLIMIT ↑] °F	86.0 °F	0.1 °F	32.0 °F	302.0 °F	Upper limit value correction value °F
[TLIMIT ↓] °F	32.0 °F	0.1 °F	32.0 °F	302.0 °F	Lower limit value correction variable °F
[TIMELIM.]	0 min = OFF	1 min	0	999	Checkout time after occurrence of a limit value transgression

If [TDS] or [SAL] is set in the continuous display, the setting values for [TLIMIT ↑] and [TLIMIT ↓] are hidden in the [LIMIT] menu:

- [TLIMIT ↓] can be changed if the continuous display is showing [Cond_1] or [RES].
- [TLIMIT ↑] is fixed at 40 °C (with TDS) and 35 °C (with SAL). If the value set at [Cond_1] for [TLIMIT ↑] is less than this value, this setting is retained.

Hysteresis: the hysteresis is specified as a %, as an absolute indication is impossible due to the extent of the measuring range. The indication refers to the values given under [LIMIT ↑] and [LIMIT ↓].

Hysteresis = *[HYST.]*

If the value has fallen below a limit value, then the limit value criteria are reset when the measured value has reached the value of the limit value plus hysteresis.

If the value has fallen below a limit value, then the limit value criteria are reset when the measured value has reached the value of the limit value minus hysteresis.

If the limit value criteria no longer exist on expiry of *[TIMELIM]*, then the control is automatically reactivated.

9.3 Setting the control [CONTROL]

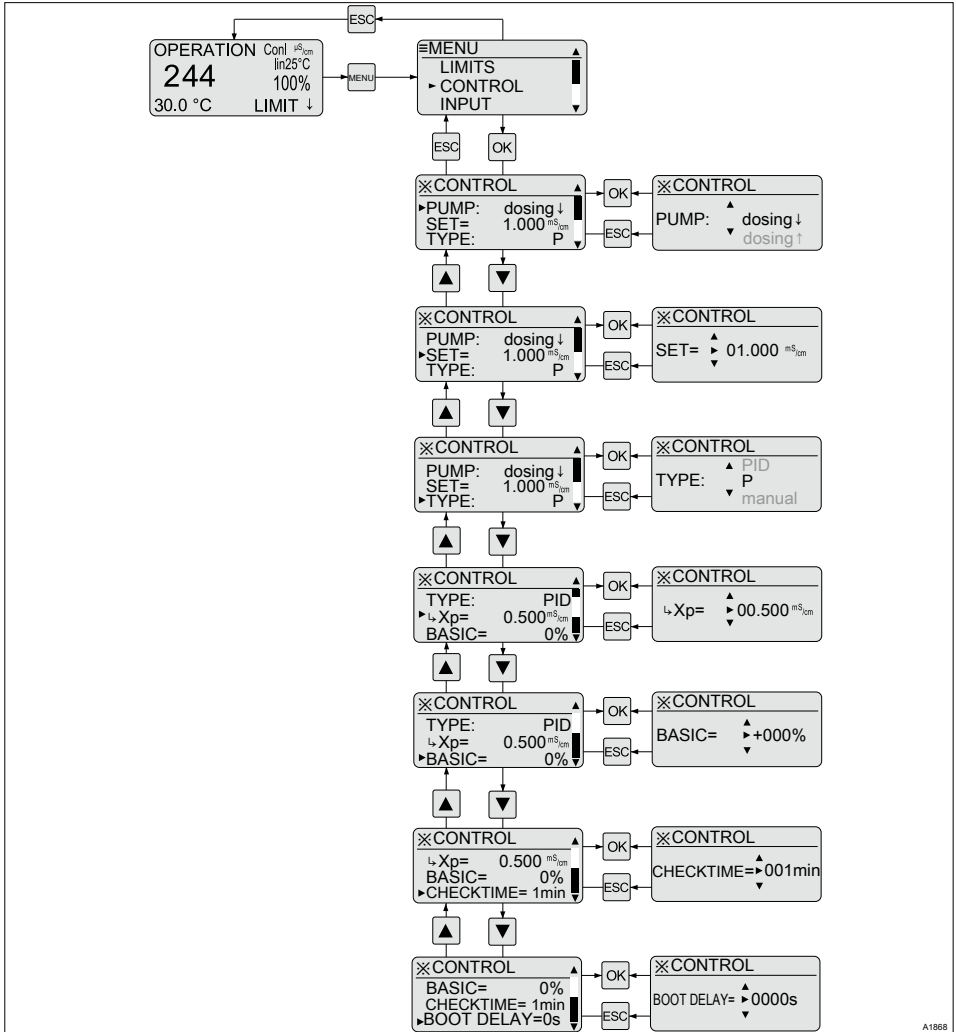

Fig. 29: Setting the control [CONTROL]

Operating menus

Setting		Possible values			
	Starting value	Increment	Lower value	Upper value	Remark
[PUMP]	[dosing ↑]	[dosing ↓] [dosing ↑]			One-way control direction ²
[SET]	1.0 mS/cm	0,001	0.000 uS/cm	2.000 S/cm	
[TYPE]	P	P Manual PID			Controller type
[↳Xp]	0.5 mS/cm	0,001	0.000 uS/cm	2.000 S/cm	P-proportion of control variable
[↳Ti]	0 s	1 s	0 s	9999 s	PID control integral action time (0 seconds = no I-proportion)
[↳Td]	0 s	1 s	0 s	2500 s	PID control derivative action time (0 seconds = no D-proportion)
[BASIC] ¹	0 %	1 %	- 100 %	100 %	Basic load
[↳MANUAL] 1	0 %	1 %	- 100 %	100 %	Manual control value

Setting	Possible values				
	Starting value	Increment	Lower value	Upper value	Remark
<i>[CHECK-TIME]</i>	0 min	1 min	0 min	999 min	Control checkout time 0 minutes = off
<i>[BOOT DELAY]</i>	30 s	1 s	0 s	9999 s	Control delay period after the start of the measuring point. After it is switched on, the unit only measures during this unit, but does not control.

1 = at an upwards direction with one-way control: 0 ...+ 100 % (setting with *[PUMP]: [dosing ↑]*), in a downward direction: - 100 ... 0 % (setting with *[PUMP]: [dosing ↓]*).

2 = When switching over the metering direction, all actuators in the controller are reset to the factory settings for the selected metering direction.

9.4 Setting inputs [INPUT]

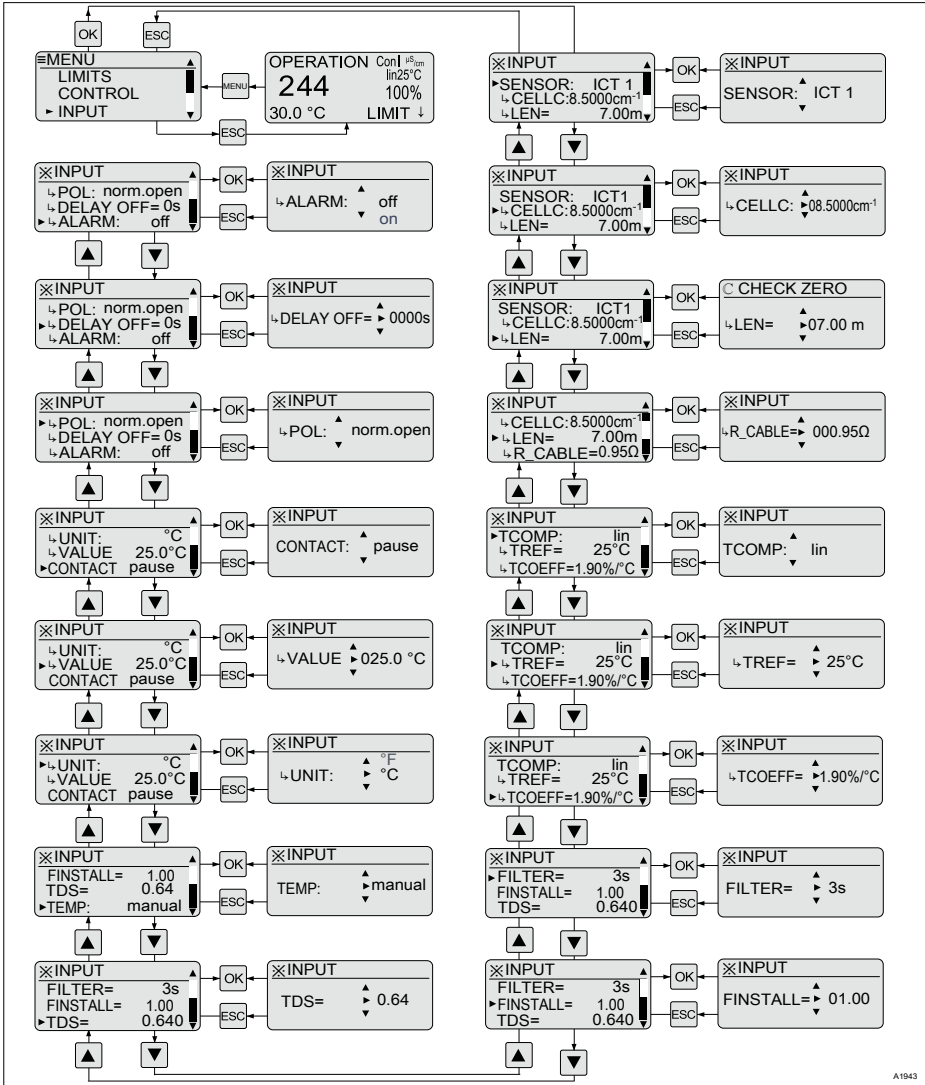

Fig. 30: Setting inputs [INPUT]

Setting		Possible values			
Display	Starting value	Increment	Lower value	Upper value	Remark
[SENSOR]	ICT 1				Sensor type
[↵ CELLC]	8.5 cm ⁻¹	0.001	0.006 cm ⁻¹	15 cm ⁻¹	Cell constant
[↵ LEN]	7 m	0.01	0 m	200 m	Cable length
[↵ R_CABLE]	0.95 Ω	0.01	0 Ω	100 Ω	Cable resistance
[TCOMP]	[off]				Temperature compensation off
	[lin]				Linear temperature compensation
	[nLF]				Non-linear temperature compensation (according to DIN EN 27888)
[↵ TREF]	25 °C	1	15 °C	30 °C	Reference temperature
[TCOEFF]	1.9 %/°C	0.1	0 %/°C	9.99 %/°C	Temperature coefficient
[FILTER]	3 s	1	3 s	30 s	Measured value filtering in seconds ¹
[FIN-STALL]	1.0	1	0	10.00	Installation factor
[TDS]	0.64	0.001	0.004	1.000	TDS conversion factor
[TEMP]	[auto]	[manual]			Correction value source (Pt100 (0), manual)
		[auto]			
[↵ UNIT]	°C	°C °F			Correction value unit
[↵ VALUE]	25.0 °C	0.1	0.0 °C	150.0 °C	Manual correction value °C

Operating menus

Setting		Possible values			
Display	Starting value	Increment	Lower value	Upper value	Remark
[↵ VALUE]	77.0 °F	0.1	32.0 °F	302.0 °F	Manual correction value °F
[CON- TACT]	[pause]	[pause] [hold]			Configuration of digital contact input
[↵ POL]	[norm.open]	[norm.open] [norm.closed]			Polarity of the contact input
[↵ DELAY OFF]	0 s	1	0 s	3600 s	Switch-off delay of contact input
[↵ ALARM]	[off]	[on] [off]			Alarm at [Hold] or [PAUSE] event

1) [FILTER]: The default value of 3 seconds is suitable in most cases. You should only increase the default value of 3 seconds with fluctuating readings, a factor that also increases the setting time of the display value.

Sensor

Selection of the sensor connected

If the connected sensor is changed, all the sensor-dependent settings are reset to their [DEFAULT] values.



Temperature sensor

- [auto]: with conductivity sensors with integral temperature sensor
- [Manual], 25 °C: with conductivity sensors without integral temperature sensor

The electrolytic conductivity of the liquid predominantly depends on the ion concentration. The geometrical conditions of the sensor surroundings and the geometry of the sensor itself have to be taken into consideration with the measurement.

The geometry of the sensor is fully described by the cell constant $[ZK]$.

The geometrical conditions of the sensor surroundings are described by the installation factor $[FINSTALL]$. The installation factor $[FINSTALL]$ does not need to be considered if the sensor head is sufficiently far away from the wall ($[a] > 30$ mm). With smaller gaps from the wall, the installation factor is higher than 1 with electrically isolating pipes (1) and lower than 1 with electrically conducting pipes (2).

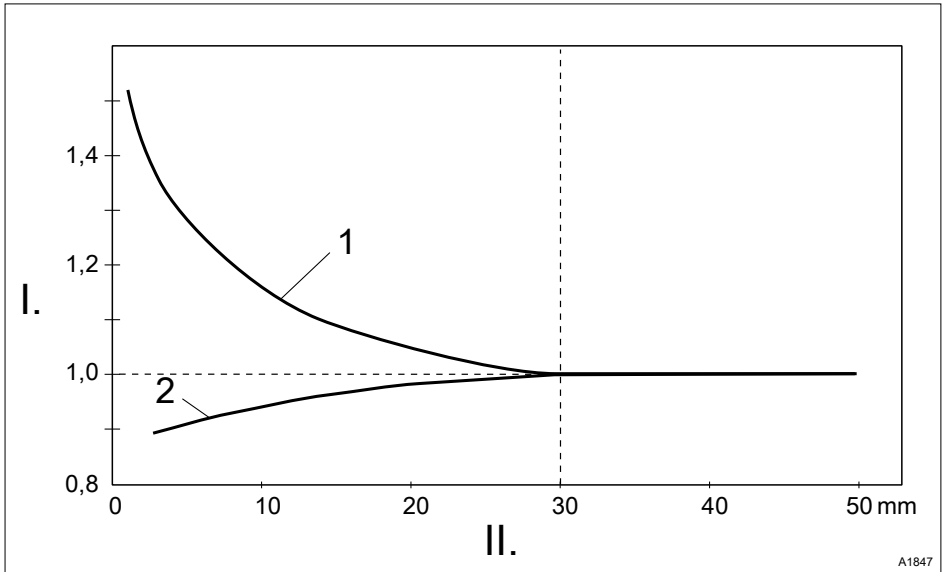

Fig. 31: Dependence of the installation factor on the distance from the wall

- I. Installation factor $[FINSTALL]$
- II. Distance from wall $[a]$

The installation factory $[FINSTALL]$ dependent on the distance of the sensor from the wall $[a]$ (for electrically isolating pipes (1) and electrically conducting pipes (2))

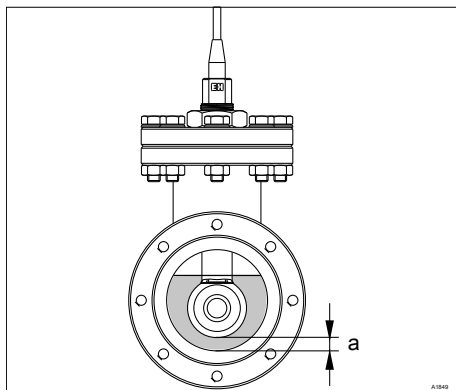
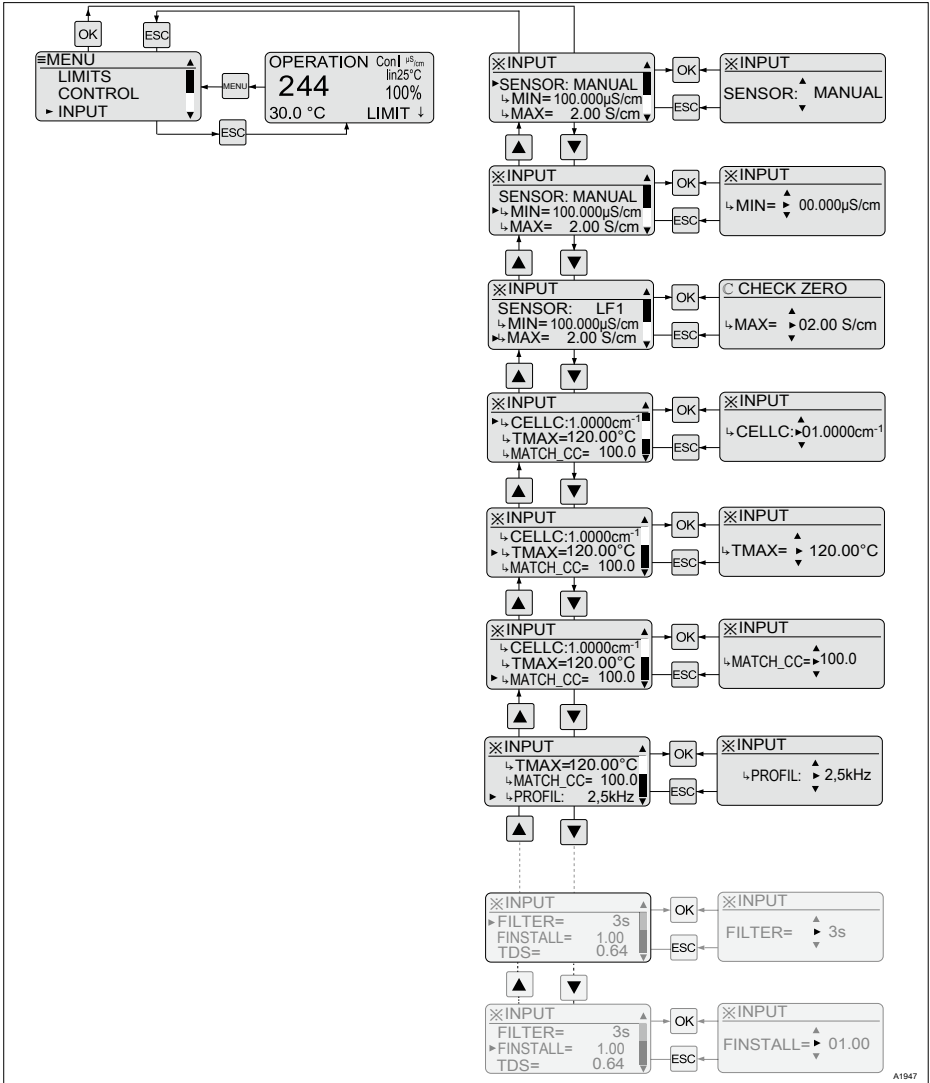

Fig. 32: Distance from wall [a]

9.5 Setting the [MANUAL] sensor in the [INPUT] menu



A1947

Fig. 33: Setting the [MANUAL] sensor in the [INPUT] menu

Setting a sensor in the *[MANUAL]* process

Setting		Possible values			
Display	Starting value	Increment	Lower value	Upper value	Remark
<i>[SENSOR]</i>	<i>[MANUAL]</i>				Sensor type
<i>[↵ MIN]</i>	100,000 μS/cm				For limit value settings when changing the sensor.
<i>[↵ MAX]</i>	2.00 S/cm				For limit value settings when changing the sensor.
<i>[↵ CELLC]</i>	1.0000 cm ⁻¹		0.0006 cm ⁻¹	99.9999 cm ⁻¹	The cell constant is ascertained by calibration.
<i>[TMAX]</i>	120.0 °C				Not used
<i>[↵ MATCH_CC]</i>	100.0		0.1	999.9	
<i>[PROFILE]</i>	2.5 kHz		1.0 kHz	5.0 kHz	The operating frequency of the inductive conductivity sensor

The prerequisite for adjusting a sensor in the *[MANUAL]* process is the knowledge about the value of the cell constant *[ZK]* and the operating frequency of the sensor. Refer to the data sheet for the sensor. Contact the sensor manufacturer if you are unaware of these values.

1. ➔ Enter 100.0 in parameter *[MATCH_CC]* in the *[INPUT]* menu.
2. ➔ Enter the control frequency of your sensor in parameter *[PROFILE]* in the *[INPUT]* menu.
Enter 2.5 kHz as the default value if you are unaware of the control frequency of your sensor.
⇒ Now calibrate the sensor.

Calibrate using a calibration solution that corresponds approximately to the conductivity of your application

3. ➔ Select the calibration menu and select *[CELLCONST]*.

4. ▶ Press **[CAL]** and use the **[▲]** or **[▼]** key to move the cursor to *[CELLCONST]* and confirm with **[OK]**.
5. ▶ Enter the temperature coefficient of the calibration solution.



The temperature coefficient of the calibration solution is specified on the storage tank for the calibration solution.

Confirm with **[OK]**.

6. ▶ Now dip the sensor into the calibration solution and gently move the sensor.
7. ▶ Wait until the conductivity and temperature measured value has stabilised.
Press **[CAL]**.
⇒ The conductivity value measured is displayed.
8. ▶ Now use the **[↵]**, **[▲]** or **[▼]** keys to enter the conductivity value measured, in accordance with the conductivity value specified on the calibration solution.
⇒ This first calibration in a known calibration solution delivers a cell constant of $[CC]_{[Test1]}$. The setting was as follows: $[MATCH_CC]_{[Test1]}$ 100.0

Calculating the valid value

9. ▶ Now use the following formula to calculate the valid value for $[MATCH_CC]$:
$$[MATCH_CC] = [MATCH_CC]_{[Test1]} * [CC]_{[Test1]} / [CC]_{\text{Manufacturer's figure}}$$

10. ▶ Enter this calculated value for $[MATCH_CC]$ in the $[INPUT]$ menu.

Recalibrate using a calibration solution that corresponds approximately to the conductivity of your application

11. ▶ Select the calibration menu and select $[CELLCONST]$.
12. ▶ Press **[CAL]** and use the **[▲]** or **[▼]** key to move the cursor to $[CELLCONST]$ and confirm with **[OK]**.
13. ▶ Enter the temperature coefficient of the calibration solution.



The temperature coefficient of the calibration solution is specified on the storage tank for the calibration solution.

Operating menus

Confirm with **OK**.

14. Now dip the sensor into the calibration solution and gently move the sensor.

15. Wait until the conductivity and temperature measured value has stabilised.

Press **CAL**.

⇒ The conductivity value measured is displayed.

16. Now use the **↙**, **▲** or **▼** keys to enter the conductivity value measured, in accordance with the conductivity value specified on the calibration solution.

⇒ The cell constant $[CC]$ has now been correctly ascertained and is available in the controller's memory.

9.6 Setting outputs [OUTPUT]

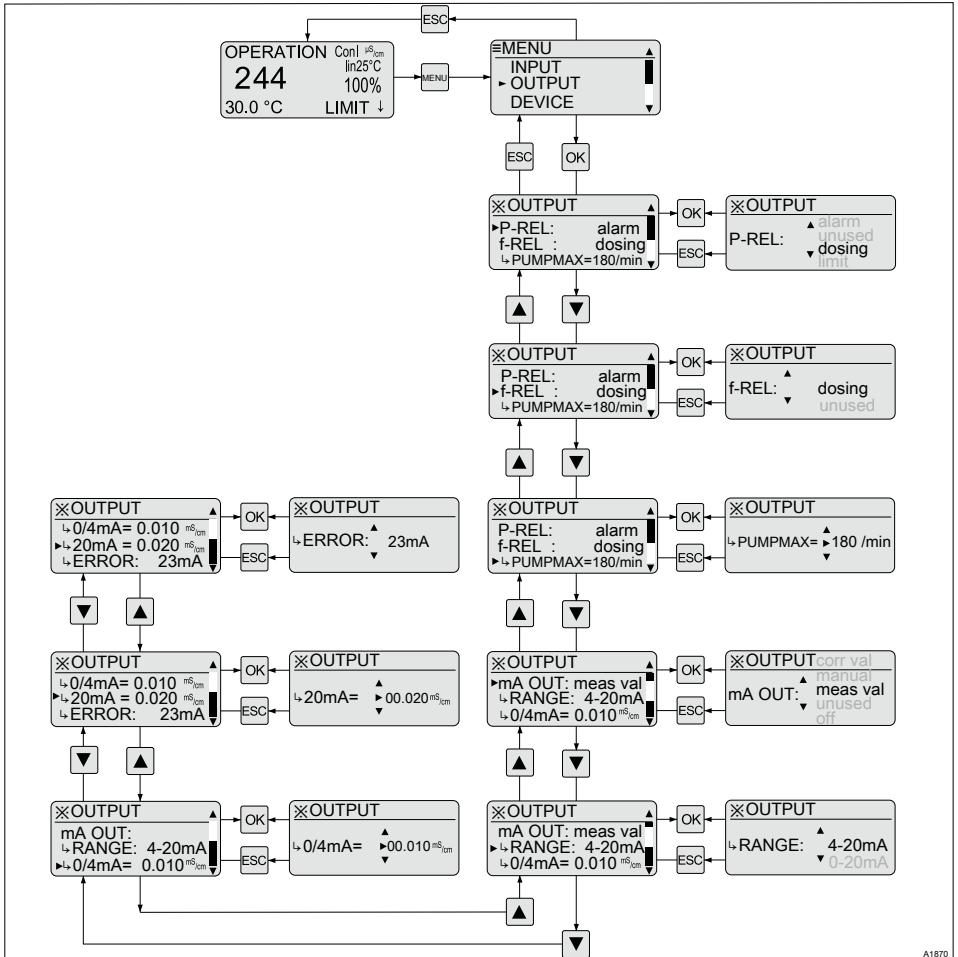

Fig. 34: Setting outputs [OUTPUT]

Operating menus

Setting	Starting value	Possible values			Remark
		Increment	Lower value	Upper value	
[P-REL] (Power relay)	[alarm]	[alarm]			Alarm relay
		[unused]			off
		[dosing]			PWM relay (Pulse Width Modulation)
		[limit]			Limit value relay
[↳PERIOD]	60 s	1 s	30 s	6000 s	Cycle time of PWM control (P-REL = dosing)
[↳MIN ON] 1	10 s	1 s	5 s	[PERIOD/4] and/or 999	Minimum switch-on period with PWM control (P-REL = dosing)
[↳DELAY ON]	0 s	1 s	0 s	9999 s	Switch-on delay limit value relay (P-REL = limit)
[↳DELAY OFF]	0 s	1 s	0 s	9999 s	Switch-off delay limit value relay (P-REL = limit)
[f-REL]	[dosing]	[dosing]			Activation of the low power relay (frequency relay)
		[unused]			

Setting	Starting value	Possible values			Remark
		Increment	Lower value	Upper value	
[↵PUMPMA X]	180 RPM	1	1 RPM	500 RPM	Maximum stroke rate of the low power relay (frequency relay)
[mA OUT] (Issued variable of the mA standard signal output)	[meas val]	[off]			[off] = off
		[meas val]			[meas val] = measured variable (conductivity)
		[corr val]			[corr val] = correction variable
		[dosing]			[dosing] = control value
		[manual]			[manual] = Manual
[↵RANGE]	4 - 20 mA	0 - 20 mA			Range of the mA standard signal output
		4 - 20 mA			
[↵0/4 mA]	0.01 mS/cm	0.001	0.000 uS/cm	2.000 S/cm	
[↵20 mA]	0.02 S/cm	0.001	0.000 uS/cm	2.000 S/cm	
[↵0/4 mA]	0.0 °C	0.1 °C	0.0 °C	150.0 °C	Temp. value assigned 0/4 mA
[↵20 mA]	100.0 °C	0.1 °C	0.0 °C	150.0 °C	Temp. value assigned 20 mA
[↵0/4 mA]	32.0 °F	0.1 °F	32.0 °F	302.0 °F	Temp. value assigned 0/4 mA

Operating menus

Setting	Possible values				Remark
	Starting value	Increment	Lower value	Upper value	
[↵20 mA]	212.0 °F	0.1 °F	32.0 °F	302.0 °F	Temp. value assigned 20 mA
[↵20 mA] ²	100 %	1 %	10 % / - 10 %	100 % / - 100 %	Control value assigned 20 mA (0/4 mA is fixed as 0 %)
[↵VALUE]	4.00 mA	0.01 mA	0.00 mA	25.00 mA	Manual current output value
[↵ERROR]	off	23 mA			Current output value in the event of an error, 23 mA
		0/3.6 mA			Current output value in the event of error, 0/3.6 mA
		off			[off] = no error current is emitted

1 = The parameter maximum is [PERIOD/4] or 999, depending on which is lower

2 = depending on the metering direction, the limits are either -10% and -100% or +10% and +100%

9.7 Setting the [DEVICE]

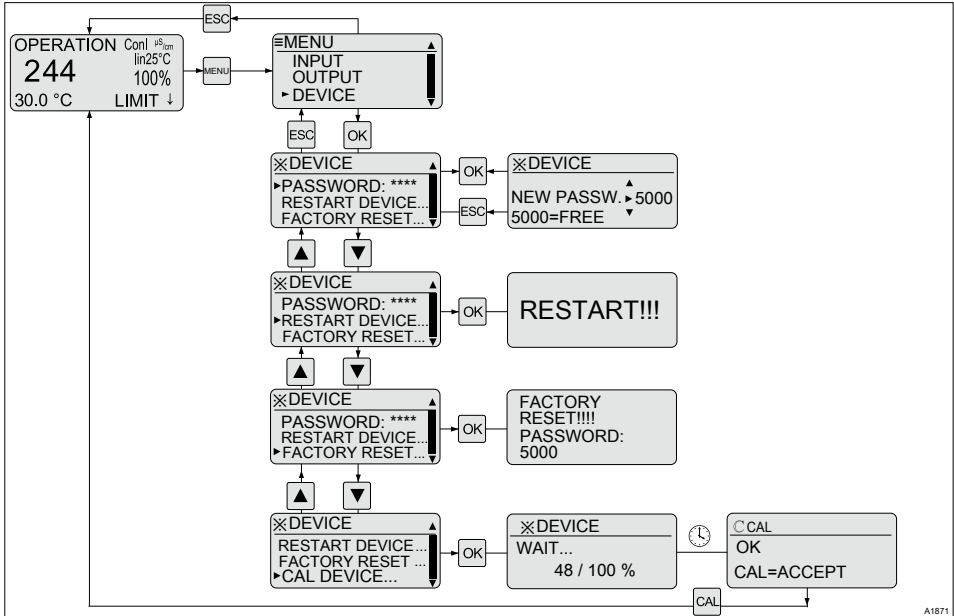



Fig. 35: Setting the [DEVICE]

Setting	Starting value	Increment	Lower value	Upper value	Remark
[PASS-WORD]	5000	1	0000	9999	5000 = no password protection
[RESTART DEVICE]					Controller is restarted

Operating menus

Setting	Possible values				Remark
	Starting value	Increment	Lower value	Upper value	
<i>[FACTORY RESET...]</i>	<i>[no]</i>	<i>[yes]</i> <i>[no]</i>	<i>[yes]</i> = <i>[FACTORY RESET!]</i>	<i>[no]</i> = no <i>[FACTORY RESET!]</i>	All the controller's parameters are reset to factory settings.
<i>[CAL DEVICE...]</i>	This function is used to calibrate the amplifier measuring chain in the controller. If the error message <i>[ERR]</i> is displayed, depending on the design of <i>[CAL DEVICE...]</i> , the PCB is damaged and the controller should be returned for repair.				

10 Control parameters and functions

- **User qualification:** trained user, see  *Chapter 3.4 'User qualification' on page 15*

10.1 DULCOMETER® Compact Controller function states

DULCOMETER® Compact Controller function states have the following priority:

- 1. 'STOP'
- 2. 'PAUSE/HOLD'
- 3. 'CAL' (calibration)
- 4. 'OPERATION' (normal mode)

"CAL" (calibration) peculiarities

- Control goes to basic load, mA measurement outputs are frozen
- New faults are detected, however they have no effect on the alarm relay or the mA output
- Detection of measurement variable relevant faults during 'CAL' (calibration process) are suppressed (e.g. LIMIT ↑)

"PAUSE" peculiarities

- Control is switched to 0% control variable. The I-proportion is saved
- New faults are detected, however they have no effect on the alarm relay or the mA output
- Special case alarm relay in 'PAUSE': If activated the output relay switches to 'PAUSE' (error message CONTACTIN)

"HOLD" peculiarities

- Control and all other outputs are frozen
- New faults are detected, however they have no effect on the alarm relay or the mA output. However the effect of already existing faults (e.g. fault current) remains
- Special case alarm relay: Activation of the frozen alarm relay is permitted (= no alarm), if all faults have been acknowledged or have disappeared
- Special case alarm relay in 'HOLD': If activated the output relay switches to 'HOLD' (error message CONTACTIN)

"STOP" peculiarities

- Control OFF
- New faults are detected, however they have no effect on the alarm relay or the mA output
- The alarm relay is switched off in 'STOP'



Peculiarities of the "START" event, i.e. switching from "STOP" to "OPERATION" (normal mode)

- Fault detection starts afresh, all existing faults are deleted

Generally applicable information

- If the cause of a fault disappears, then the fault message in the LCD footer disappears.
- A previously existing 'PAUSE/HOLD' state is not influenced by starting a 'CAL' (calibration) process. If during 'CAL' (calibration) the functional state 'PAUSE/HOLD' is released, then all states will remain frozen until the end of the 'CAL' (calibration) process.

Control parameters and functions

- If 'CAL' (calibration) is started while functional state 'OPERATION' (normal mode) is active, then the functional state 'PAUSE/HOLD' is ignored until 'CAL' (calibration) completes. However STOP/START is possible at any time
- An alarm can be acknowledged or removed as follows: By clearing all faults by pressing the  key and the  key while the continuous display is visible

10.2 [STOP/START] key



Control is started / stopped by pressing . You can press regardless of the menu currently displayed. However the [STOP] state is only shown in the continuous display.

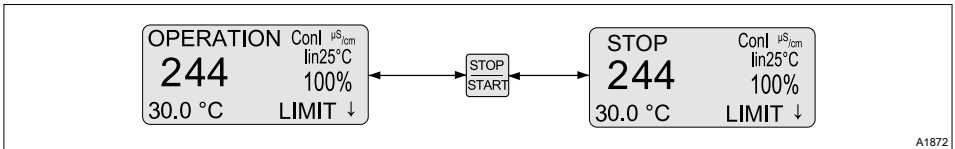

A1872

Fig. 36: key

When the controller is first switched on, it is in [STOP] mode.

In the event of defined error conditions, the controller switches to [STOP] mode. The control is then off (= 0 % control variable).

To differentiate the operating status [STOP], caused by an error, from the operating status [STOP], caused by pressing , [ERROR STOP] is displayed instead of [STOP].

Pressing therefore causes the operating status [ERROR STOP] to become [STOP]. Pressing once more causes the controller to start up again.

In [STOP] status, start the controller manually by pressing .

Controller [STOP] means:

- Control is stopped
- The P-relay functioning as a limit value relay and as a PWM relay are switched to a de-energised state
- The P-relay acting as an alarm relay is activated (no alarm)

The controller restarting causes the following:

- If a [STOP] status existed, then you have to manually start the controller after switching on again.
- Error detection starts afresh, all existing errors are erased

10.3 Priming [*PRIME*]

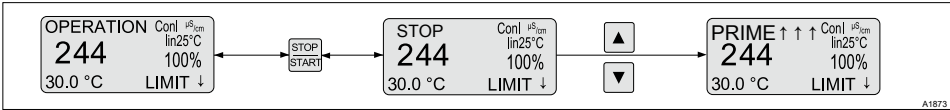



Fig. 37: Priming, e.g. to vent a pump

While the continuous display is visible, in [*STOP*] and [*OPERATION*] modes, you can start the priming function [*PRIME*] by simultaneously pressing  and .

Depending on the configuration of the controller, the output relay [*P-REL*] is actuated at 100 %, the frequency relay [*f-REL*] is actuated at 80 % of "PUMPMAX" and 16 mA is output at the mA output. However this is only the case if these outputs are set as [*dosing*] actuators.

The output relay [*P-REL*] starts after priming in an activated state.

You can use this function, for example, to transport the feed chemical up to the pump to bleed the metering line.

10.4 Hysteresis limit value

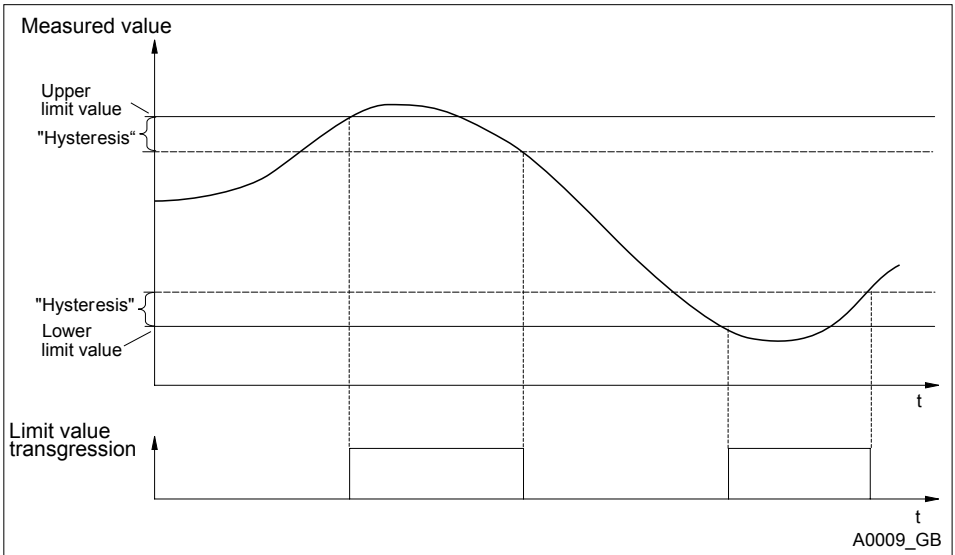

Fig. 38: Hysteresis

Upper limit value = $[LIMIT \uparrow]$

Lower limit value = $[LIMIT \downarrow]$

The range between $[LIMIT \uparrow]$ and $[LIMIT \downarrow]$ is the valid measuring range.

The controller has a $[hysteresis]$, which is set as a % to the respective $[LIMIT]$ value.

An error message is emitted if, for example, $[HYST] = 5\%$ and $[LIMIT \uparrow]$ is exceeded. If the level falls below $0.95 \cdot [LIMIT \uparrow]$, the error message is retracted. If the level calls below $[LIMIT \downarrow]$, the error message is issued, which is retracted again after exceeding $1.05 \cdot [LIMIT \downarrow]$.

10.5 Temperature correction variable





Available temperature

A temperature reading for the conductivity always has to be available, either by a temperature measurement or a manual temperature setpoint.

The correction variable compensates for the effect of the temperature of the medium on the measured value. The correction variable is the temperature of the medium to be measured.

Operating modes

- *[auto]*: The controller analyses the temperature signal from the temperature sensor connected
 - For measurements using a temperature sensor (0 ... 150 °C)
- *[manual]*: The temperature of the medium to be measured has to be measured by the user. The determined value is then entered using the keys:  and  in the *[VALUE]* parameter into the controller and is saved using .
- This setting is needed for measurements where the medium to be measured has a constant temperature. The temperature is taken into consideration in the control.

10.6 Checkout time for measured variable and correction variable

Error text	Description
LIMIT ERR	Checkout time of the measured variable
TLIMITERR	Checkout time of the correction variable

If upon the expiry of the checkout time, the valid measuring range is not reached, then the DULCOMETER® Compact Controller exhibits the following behaviour:

- **LIMIT ERR:** The control is switched off. An error current is emitted, provided the output is configured as a measured variable output
- **TLIMITERR:** The control is switched off. An error current is emitted, provided the output is configured as a correction variable output or a measured variable output

Initially the transgression of a limit is only a limit value transgression. This leads to a 'WARNING'. Switching on the control time 'TIMELIM' (> 0 minutes), creates an alarm from the limit value transgression. In the event of a [TLIMITERR] a, the control switches to [STOP].

10.7 Checkout time control



Monitoring of the control path

The checkout time monitors the control path. The checkout time mechanism permits detection of possible defective sensors.



Dead time determination

Each control path has a dead time. The dead time is the time, which the control path requires to detect a change or addition of metered chemicals using its own instrumentation.

You must select the checkout time so that it is greater than the dead time. You can determine the dead time, by operating the metering pump in manual mode and, for example, dosing acid.

! NOTICE!

Dead time determination

You should only determine the dead time if the current process cannot be negatively influenced by the manual metering.

You must determine the time, which the control path (i.e. the entirety of controllers, sensors, measurement water, flow gauges, etc.) requires to detect a first change in the measured value starting from the beginning of dosing. This time is the 'dead time'. A safety margin, e.g. 25%, must be added to this dead time. You must allocate an appropriate safety margin for your own particular process.

The parameter *'LIMIT'* can be used to set a limit for the control variable. If the control variable exceeds this limit value, the CHECKTIME fault is triggered (checkout time of the control has elapsed). The control is switched to basic load and a fault current output.

10.8 Power relay "P-REL" as limit value relay

The power relay *'P-REL'* can be configured as a limit value relay. It always act only on the measurement variable, whereby the limits are set in *'LIMITS'*. The relay is activated upon infringement of either the top or lower limit values.

Constant checking is carried out to determine whether a limit has been infringed and if this is interrupted with the power relay configured *'P-REL=limit'* for at least *'DELAY ON'* seconds, then the relay is activated. If the limit value transgression disappears for at least *'DELAY OFF'* seconds, then the limit value relay is again deactivated.

The limit value relay is deactivated immediately upon: *'STOP'*, user calibration, *'PAUSE'* and *'HOLD'*.

10.9 Setting and functional description of "Relay Used as a Solenoid Valve"

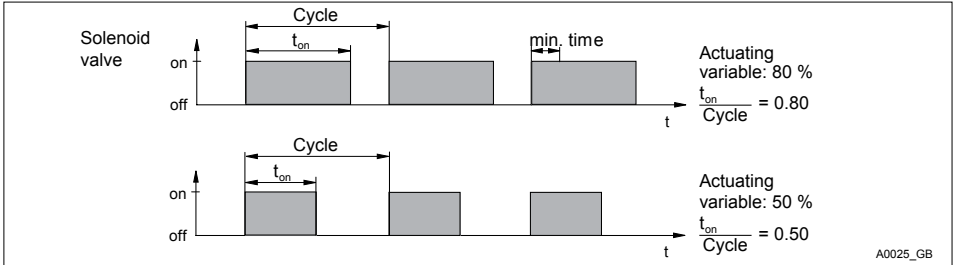

Fig. 39: Solenoid valve (= P-REL: dosing)

min. time [MIN ON]

Cycle = [PERIOD] (in seconds)



Solenoid valve switching times

The switching times of the relay (solenoid valve) depend on the cycle time, the control variable and the 'min. time' (smallest permissible switch-on time for the connected device). The actuating variable determines the ratio $t_{on}/cycle$ and thus also the switching times.

The 'min. time' affects the switching times in two situations:

1. Theoretical switching time < min. time

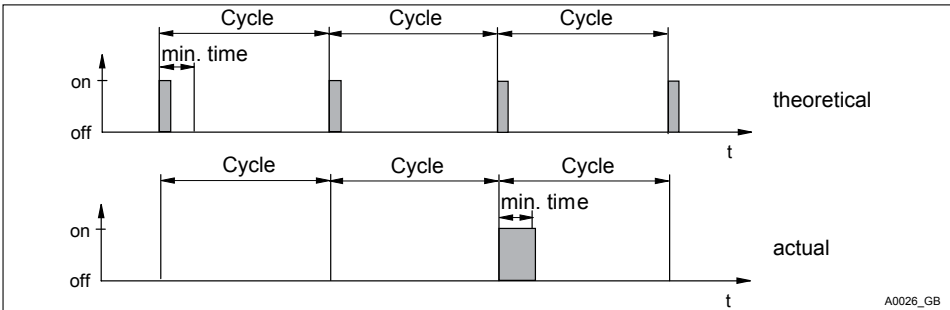

Fig. 40: Theoretical switching time < min. time

min. time [MIN ON]
Cycle = [PERIOD] (in seconds)

The DULCOMETER® Compact Controller does not switch on for a certain number of cycles until the sum of the theoretical switching times exceeds 'min. time'. Then it switches for the duration of this total time.

2. Theoretical switching time > (cycle - min. time)

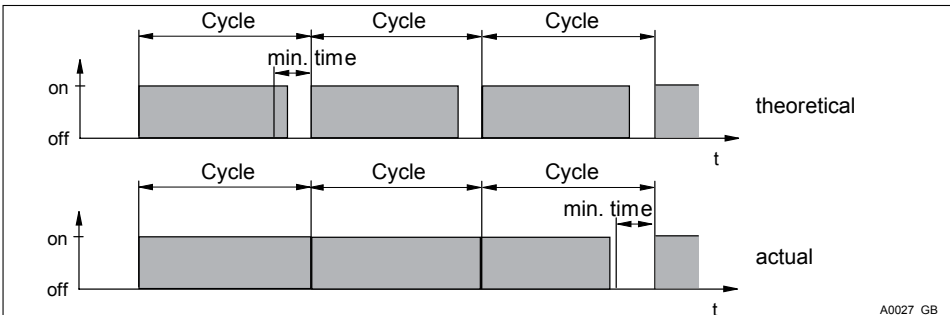

Fig. 41: Theoretical switching time > (cycle - min. time) and calculated switching time < cycle

min. time [MIN ON]
Cycle = [PERIOD] (in seconds)

The DULCOMETER® Compact Controller does not switch off for a certain number of cycles until the differences between the cycle and the theoretical switching time exceed 'min. time'.

10.10 Alarm relay

The alarm relay triggers in *'OPERATION'* (normal mode) if an error occurs which has been defined as *'ERROR'* and not just as *'WARNING'*.

The error message *'ALARM'* in the continuous display is marked with a * (star) and can be acknowledged with the **OK** key. The alarm and the * will then disappear.

10.11 "Error logger" operating mode

The last three errors are displayed. Also displayed is how long ago (in minutes) they occurred. When a new fault occurs, the oldest fault is deleted.

Faults are only shown which occur in operating status *'OPERATION'*, i.e. not in operating status *'STOP'*, *'CAL'* (user calibration), *'HOLD'* or *'PAUSE'*.

Only *'ERRORs'* are shown, not *'WARNINGS'*, e.g. a *'LIMIT ERR'* is shown, but not *'LIMIT ↑'*.

A fault, whose display has lasted for 999 minutes is automatically deleted from the *'Error Logger'*. The *'Error Logger'* is neither saved nor backed up in the event of power loss.

11 Maintenance

- **User qualification:** trained user, see  *Chapter 3.4 'User qualification' on page 15*

The controller is maintenance- free.

11.1 Error messages

- **User qualification for diagnosis:** trained user, see  *Chapter 3.4 'User qualification' on page 15*. Further qualifications depend on the type and scope of possible troubleshooting measures to be carried out.



Measuring technology-specific errors: [INPUT ↑]

The electrical sensor signal directly on the conductivity sensor input is too high.



Measured variable-specific errors: [TDS ↑]

> 2000: If the calculated [TDS] value is over 2000.



Measured variable-specific errors: [SAL ↑]

> 70: If the calculated [SAL] value is over 70.



Error detection following device start

The majority of errors are only displayed with a 10-second delay following the start-up of the unit.

Tab. 10: Error messages

Error message	[Error] [Warning]	Brief description of fault
[RANGE ↓]	[E]	The measured variable falls below the measuring range
[RANGE ↑]	[E]	The main measured variable exceeds the measuring range
[T RANGE ↓]	[E]	Temperature value falls below the measuring range
[T RANGE ↑]	[E]	Temperature value exceeds the measuring range
[CAL ERROR]	[E]	Calibration error during last calibration performed by the user
[CHECK-TIME]	[E]	See chapter ↗ Chapter 10.7 'Checkout time control' on page 93
[mA RANGE ↑]	[E]	The current emitted at the mA standard signal output is higher than 20 mA. This does not apply with the issue of the 23 mA error current
[mA RANGE ↓]	[E]	The current emitted at the mA standard signal output is below 0/4 mA. This does not apply with the issue of the 0/3.6 mA error current
[LIMIT ↑]	[W]	Measured variable is higher than the limit set
[LIMIT ↓]	[W]	Measured variable is lower than the limit set
[T LIMIT ↑]	[W]	Correction measured variable higher than the limit set
[T LIMIT ↓]	[W]	Correction measured variable higher than the limit set
[LIMIT ERR]	[E]	See chapter ↗ Chapter 10.6 'Checkout time for measured variable and correction variable' on page 93
[TLIMITERR]	[E]	See chapter ↗ Chapter 10.6 'Checkout time for measured variable and correction variable' on page 93
[NO CAL]	[W]	No calibration has been performed by the user
[CONTACTACTIN]	[E]	Alarm triggered by the contact input ([INPUT] menu: [ALARM=on] selected)
[TDS ↑]	[W]	The [TDS] value is too high. Continuous display: > 2000
[SAL ↑]	[W]	The [SAL] value is too high. Continuous display: > 70

Maintenance

Error message	<i>[Error]</i> <i>[Warning]</i>	Brief description of fault
<i>[INPUT↑]</i>	<i>[E]</i>	Conductivity signal exceeds the input measuring range
<i>[TEST?]</i>	<i>[E]</i>	Check the sensor's connection. Cable breakage? No sample water?

Tab. 11: Response of the unit due to the error messages

Error message	Control mode	mA measuring output	mA correction output	Limit value relay	Suppressed during user calibration
[RANGE↓]	Basic load	Error current	-	-	yes
[RANGE↑]	Basic load	Error current	-	-	yes
[T RANGE↓]	Basic load	Error current	Error current	-	yes
[T RANGE↑]	Basic load	Error current	Error current	-	yes
[CALERROR]	-	-	-	-	yes
[LOW ZERO]	-	-	-	-	yes
[CHECKTIME]	Basic load	Error current	-	-	no
[mA RANGE↑]	-	-	-	-	no
[mA RANGE↓]	-	-	-	-	no
[LIMIT↑]	-	-	-	activation ¹	yes
[LIMIT↓]	-	-	-	activation ¹	yes
[T LIMIT↑]	-	-	-	-	no
[T LIMIT↓]	-	-	-	-	no
[LIMIT ERR]	Stop	Error current	-	-	yes
[TLIMITERR]	Stop	Error current	Error current	-	no
[NOCAL]	-	-	-	-	yes
[CONTACTIN]	-	-	-	-	no
[TDS↑]	-	-	-	-	no
[SAL↑]	-	-	-	-	no
[INPUT↑]	Basic load	Error current	-	-	no

¹) If the functionality of the limit value relay is activated and the switch-on delay is overcome.

11.2 Changing the fuse, DULCOMETER® Compact Controller



WARNING!

Danger from electrical voltage

Possible consequence: Fatal or very serious injuries.

- The DULCOMETER® Compact Controller does not have a mains switch
- When working inside the control unit, disconnect the control unit from the mains power via an external switch or by removing the external fuse



NOTICE!

Use only 5 x 20 mm micro-fuses

Possible consequence: Damage to the product or its surroundings

- 5x20 T 0.315 A
- Part number 732404

Fuse change

The mains fuse is located in a sealed fuse holder in the inside of the device.

- 1.** ➤ Disconnect the controller from the mains power
- 2.** ➤ Open the controller and fold the controller housing top section to the left
- 3.** ➤ Remove the PCB cover
- 4.** ➤ Remove the micro-fuse using a suitable tool
- 5.** ➤ Fit the micro-fuse using a suitable tool
- 6.** ➤ Refit the PCB cover
- 7.** ➤ Replace controller housing top section and close the controller

12 Technical data on DULCOMETER® Compact Controller

12.1 Permissible ambient conditions



Degree of protection (IP)

The controller fulfils the IP 67 degree of protection requirements (wall/pipe mounting) or IP 54 (control panel mounting). This degree of protection is only achieved if all seals and threaded connectors are correctly fitted.

Tab. 12: Permissible ambient operating conditions

Temperature	-10 °C ... 60 °C
Air humidity	< 95 % relative air humidity (non-condensing)

Tab. 13: Permissible ambient storage conditions

Temperature	-20 °C ... 70 °C
Air humidity	< 95 % relative air humidity (non-condensing)

12.2 Dimensions and weights

Complete device:	128 x 137 x 76 mm (W x H x D)
Packaging:	220 x 180 x 100 mm (W x H x D)
Weight of device without packaging:	approx. 0.5 kg
Gross weight of device with packaging:	approx. 0.8 kg

12.3 Material data

Part	Material
Housing lower and upper section	PC-GF10
Bracket rear side housing bottom section	PPE-GF20
Operating film	Polyester PET membrane
Seal	Expanded PUR
Cover screws	Stainless steel A2
Profile seal (control panel mounting)	Silicone

12.4 Chemical Resistance

The device is resistant to normal atmospheres in plant rooms

12.5 Sound Pressure Level

No noise generation measurable

13 Electrical data

Mains connection	
Nominal voltage range	100 ... 230 VAC \pm 10 %
Frequency	50 ... 60 Hz
Power consumption	50 ... 100 mA

Main and auxiliary inputs, display and measuring ranges

Tab. 14: Main input:

Variable	Display range
Specific inductive conductivity	0.1 ... 1.9 μ S/cm
	2.0 ... 19.9 μ S/cm
	20.0 ... 199.9 μ S/cm
	200 ... 1999 μ S/cm
	2.00 ... 19.99 mS/cm
	20.0 ... 199.9 mS/cm
	200 ... 1999 mS/cm
Specific resistance.	0.001 ... 1.999 Ω cm
	2.00 ... 19.99 Ω cm
	20.0 ... 199.9 Ω cm
	0.200 ... 1.999 Ω cm
	2.0 ... 19.9 Ω cm
	20 ... 199 Ω cm
	0.20 ... 1.99 M Ω cm
	2.0 ... 19.9 M Ω cm
	20 ... 199 M Ω cm
	200 ... 999 M Ω cm

Electrical data

Variable	Display range
TDS (total dissolved solids)	0 ... 2000 ppm (mg/l)
SAL (salinity)	0.0 ... 70.0 ‰ (g/kg)

Maximum cable length of the sensor cable 20 metres

Tab. 15: Auxiliary input:

Variable	Display range
Temperature Pt100/Pt1000 (automatic detection)	Cable length 10 m: - 20 °C ... 150 °C
	Cable length 50 m: - 20 °C ... 120 °C

Measuring accuracy

Variable	Sensor	Measuring range	Accuracy
Specific inductive conductivity	ICT1	200 µS/cm ... 1000 mS/cm	3 % of measured value ± 20 µS/cm
	ICT2	5 µS/cm ... 2000 mS/cm	2 % of measured value ± 1 µS/cm
	CLS52	50 µS/cm ... 2000 mS/cm	2 % of measured value ± 1 µS/cm
Specific electrical resistance.	ICT1	1 Ωcm ... 5 kΩcm	
	ICT2	0.5 Ωcm ... 200 kΩcm	
	CLS52	0.5 Ωcm ... 20 kΩcm	
Temperature	Pt100	- 20 °C ... 150 °C	< 0.8 % of the measuring range
Temperature	Pt1000	- 20 °C ... 150 °C	< 0.5 °C

Cell constant

- Setting range of the cell constant K(1/cm): 0.005 ... 99.9

The mains connection is isolated from other switching parts by reinforced insulation. The unit has no mains switch; a fuse is fitted.

Output relay (P-relay)	
Load capacity of switching contacts	5 A; no inductive loads

Outputs galvanically isolated from other switching parts by reinforced insulation.

Digital input	
Open circuit voltage	22 V DC max.
Short circuit current	6.5 mA
Max. switching frequency	Static. For switching processes like 'PAUSE', 'HOLD' etc.

! NOTICE!

Do not supply with voltage

To connect an external semiconductor or mechanical switch.

mA output	0 ... 20 mA	4 ... 20 mA	manual
Current range	0 ... 20.5 mA	3.8 ... 20.5 mA	0 ... 25 mA
In the event of a fault	0 and/or 23 mA	3.6 and/or 23 mA	
Max. load	480 Ω at 20.5 mA		
Max. output voltage	19 V DC		
Overvoltage-resistant up to	± 30 V		
Output accuracy	0.2 mA		

Electrical data

The mA output is galvanically isolated from all other connections (500 V)

Pump control (f-relay)	
Max. switching voltage:	50 V (protective low voltage)
Max. switching current:	50 mA
Max. residual current (open):	10 μ A
Max. resistance (closed):	60 Ω
Max. switching frequency (HW) at 50 % filling factor	100 Hz

Digital output galvanically isolated from all other connections by OptoMos relay.

14 Spare parts and accessories

Spare parts	Part number
Fine fuse 5x20 T 0.315 A	732404
Wall/tube retaining bracket	1002502
Guard terminal top part (knurled nut)	733389
Measured variable labels	1002503
DMT fixing strap	1002498
Cable connection set DMTa/DXMa (metric)	1022312
Controller housing lower part (processor/PCB), fully assembled	Identity code DCCA_E_E1 ...
Controller housing top part (display/operating part), fully assembled	Identity code DCCA_E_E2 ...

Accessories	Part number
Mounting kit for control panel installation	1037273
Check strap	1035918

15 Replacing spare part units

- **User qualification, mechanical installation:** trained qualified personnel, see *Chapter 3.4 'User qualification' on page 15*
- **User qualification, electrical installation:** Electrical technician, see *Chapter 3.4 'User qualification' on page 15*

CAUTION!

Check strap for strain relief

Possible consequence: Material damage.

The ribbon cable and its base cannot be mechanically stressed. Hence it is essential when mounting the controller in the control panel, that the check strap (part number 1035918) is fitted for strain relief and mechanical fixing. Without the check strap, the ribbon cable or its base could be damaged if they were to fall out of the top part of the controller housing.

15.1 Replacing the top part of the housing

NOTICE!

Ribbon cable base

The base of the ribbon cable is firmly soldered onto the PCB. The base cannot be removed. Open the base lock (3) to loosen the ribbon cable, see Fig. 42

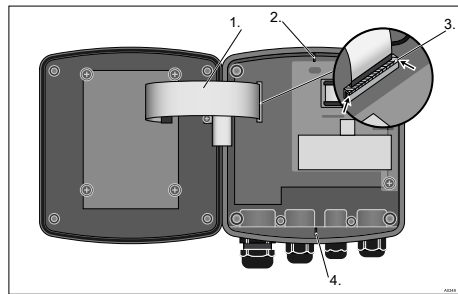

Fig. 42: Loosening the ribbon cable

1. Undo four screws and open the DULCOMETER® Compact Controller
2. Open the right and left lock (3) (arrows) on the base and pull the ribbon cable (1) out of the socket
3. The catches (2 and 4) are not needed with units for control panel installation.

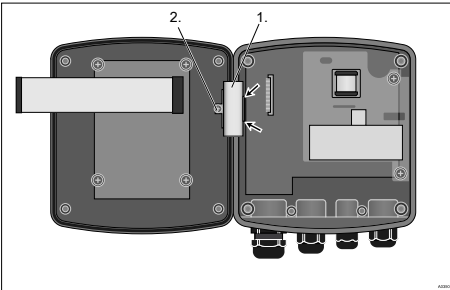

Fig. 43: Dismantling the hinge

4. ➔ Remove the screw (2), unclip the hinge (1) on the lower part of the controller housing (arrows) and remove the hinge
5. ➔ With control panel installation: Remove the two screws and remove the strain relief

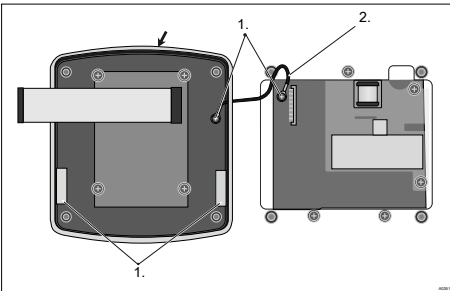

Fig. 44: With control panel installation: Fit the profile seal onto the top part of the controller housing

6. ➔ With control panel installation: Position the profile seal (arrow) evenly into the groove in the top part of the DULCOMETER® Compact Controller housing. Arrange the flaps (3) as shown in the figure
7. ➔ With control panel installation: Secure the strain relief (2) using two screws (1)

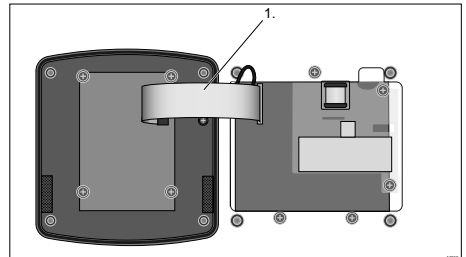

Fig. 45: Pushing and locking the ribbon cable in its base

8. ➔ Push and lock the ribbon cable (1) in its base
9. ➔ Fit the hinge
10. ➔ Screw the top part of the controller housing onto the lower part of the DULCOMETER® Compact Controller housing
11. ➔ With control panel installation: Re-check that the profile seals are fitted properly
 - ⇒ Re-check that the seal is seated properly. Only if the mounting is correct, can IP 67 (wall/pipe mounting) or IP 54 (control panel mounting) degree of protection be achieved

15.2 Replacing the lower part of the housing (wall/tube retaining bracket)

Complete commissioning of the controller

Once the lower part of the housing has been replaced, it is necessary to fully commission the measuring and control point, as the new lower part of the housing does not have specific settings, only factory settings.

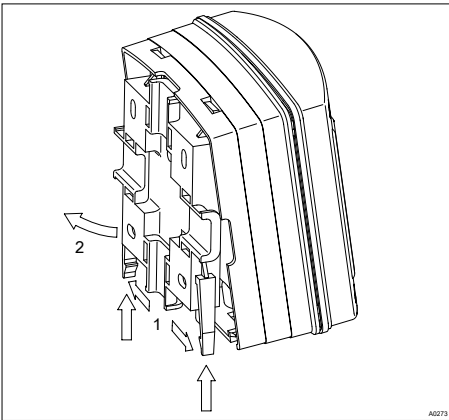

Fig. 46: Removing the wall/tube retaining bracket

1. Remove the wall/tube retaining bracket. Pull the two snap-hooks (1) outwards and push upwards

NOTICE!

Ribbon cable base

The base of the ribbon cable is firmly soldered onto the PCB. The base cannot be removed. Open the base lock (3) to loosen the ribbon cable, see Fig. 42

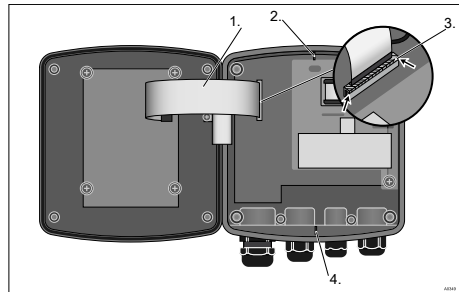

Fig. 47: Loosening the ribbon cable

2. Undo four screws and open the DULCOMETER® Compact Controller
3. Open the right and left lock (3) (arrows) on the base and pull the ribbon cable (1) out of the base. The catches (2 and 4) are used to align the two halves of the housing.

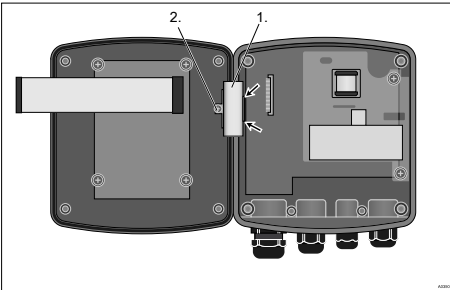

Fig. 48: Dismantling the hinge

4. ➤ Remove the screw (2), unclip the hinge (1) on the lower part of the controller housing (arrows) and remove the hinge
5. ➤ Label the cable connectors fitted to distinguish them and remove the cables from the lower part of the controller

Preparing the new lower part of the controller housing

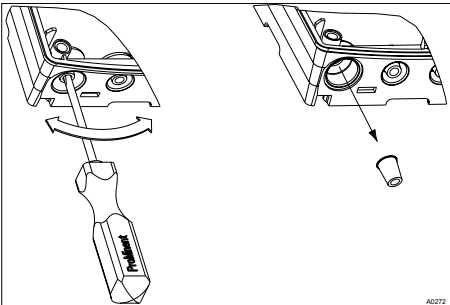

Fig. 49: Punching out the threaded holes

6. ➤



*Large threaded connection
(M 20 x 1.5)*

*Small threaded connection
(M 16 x 1.5)*

Punch out as many threaded holes on the bottom of the lower part of the controller housing as required

Fit the cable and threaded connectors

7. ➤ Guide the cable into the respective reducing inserts
8. ➤ Insert the reducing inserts into the threaded connectors
9. ➤ Guide the cable into the controller
10. ➤ Connect the cable as indicated in the terminal diagram
11. ➤ Screw in the required threaded connectors and tighten
12. ➤ Tighten the threaded connector clamping nuts so that they are properly sealed

Refit the controller

13. ➤ Fit the hinge

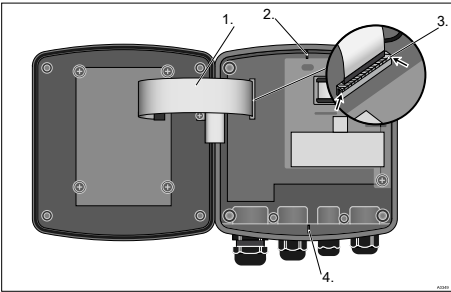
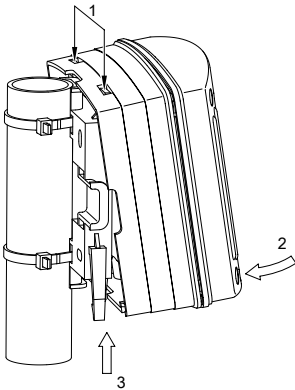

Fig. 51: Suspend and secure the DULCOMETER® Compact Controller

- 17.** ➤ Suspend the DULCOMETER® Compact Controller at the top (1) in the wall/tube retaining bracket and push using light pressure at the bottom (2) against the wall/pipe retaining bracket. Then press upwards (3) until the DULCOMETER® Compact Controller audibly snaps into position

Fig. 50: Fix the ribbon cable

- 14.** ➤ Push and lock the ribbon cable (1) in its base. The catches (2 and 4) are used to align the two halves of the housing.
- 15.** ➤ Screw the top part of the controller housing onto the lower part of the DULCOMETER® Compact Controller housing
- 16.** ➤ Re-check that the seal is seated properly. IP 67 degree of protection (wall/pipe-mounting) can only be provided if the installation is correct



A0275

15.3 Replacing the lower part of the housing (control panel installation)

Complete commissioning of the controller

Once the lower part of the housing has been replaced, it is necessary to fully commission the measuring and control point, as the new lower part of the housing does not have specific settings, only factory settings.

NOTICE!

Ribbon cable base

The base of the ribbon cable is firmly soldered onto the PCB. The base cannot be removed. Open the base lock (3) to loosen the ribbon cable, see Fig. 42

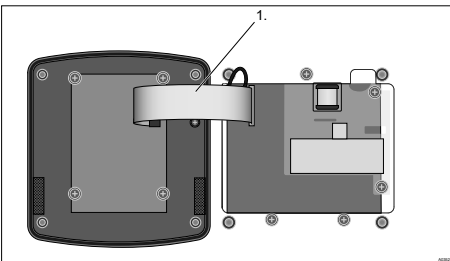

Fig. 52: Loosen the ribbon cable from the base

1. ➤ Undo four screws and open the DULCOMETER® Compact Controller
2. ➤ Open the right and left lock on the base and pull the ribbon cable (1) out of the base.

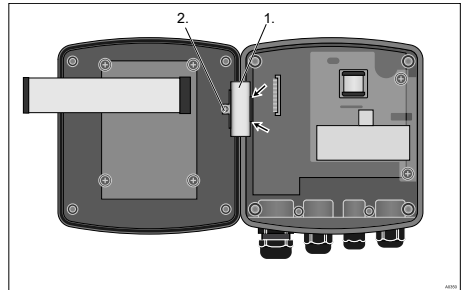

Fig. 53: Dismantling the hinge

3. ➤ Remove the screw (2), unclip the hinge (1) on the lower part of the controller housing (arrows) and remove the hinge

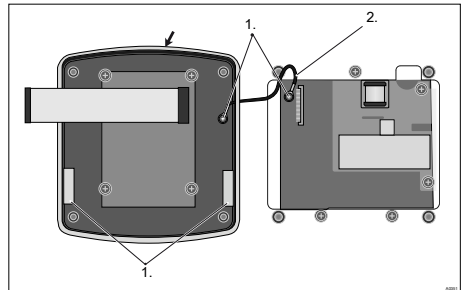

Fig. 54: Removing the strain relief

4. ➤ Remove the strain relief (2). Remove the screws (1) to do so.

Replacing spare part units

5. → Check the profile seal (arrow), then position the profile seal evenly into the groove in the top part of the DULCOMETER® Compact Controller housing. Arrange the flaps (3) as shown in the figure
6. → Remove the top part of the controller housing (3 fixing bolts)
7. → Label the cable connectors fitted to distinguish them and remove the cables from the lower part of the controller

Preparing the new lower part of the controller housing

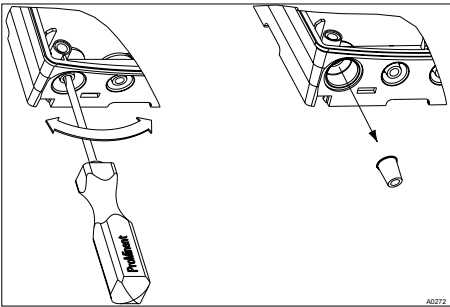

Fig. 55: Punching out the threaded holes

8. →



Large threaded connection
(M 20 x 1.5)

Small threaded connection
(M 16 x 1.5)

Punch out as many threaded holes on the bottom of the lower part of the controller housing as required

Fit the cable and threaded connectors

9. → Guide the cable into the respective reducing inserts
10. → Insert the reducing inserts into the threaded connectors
11. → Guide the cable into the controller
12. → Connect the cable as indicated in the terminal diagram
13. → Screw in the required threaded connectors and tighten
14. → Tighten the threaded connector clamping nuts so that they are properly sealed

Refit the controller

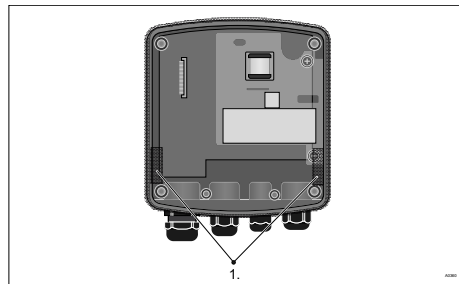

Fig. 56: Fitting the profile seal on the lower part of the controller housing

- 15.** ▶ Use pliers to break off the catches. They are not needed for control panel installation

Position the profile seal evenly around the top edge of the lower part of the DULCOMETER® Compact Controller housing. Arrange the flaps (1) as shown in the figure

- ⇒ Ensure that the profile seal evenly surrounds the top edge of the housing.

- 16.** ▶ Insert the lower part of the DULCOMETER® Compact Controller housing with the profile seal from behind into the cut-out and use three screws to secure it in place

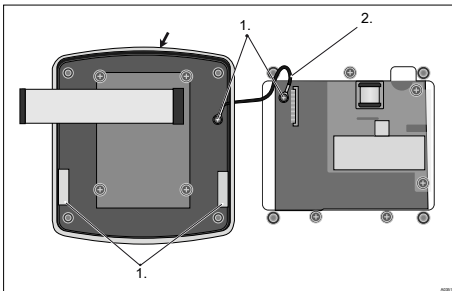

Fig. 57: Fit the profile seal onto the top part of the controller housing

- 17.** ▶ Position the profile seal (arrow) evenly into the groove in the top part of the DULCOMETER® Compact Controller housing. Arrange the flaps (3) as shown in the figure

- 18.** ▶ Secure the strain relief (2) using two screws (1)

- 19.** ▶ Fit the hinge

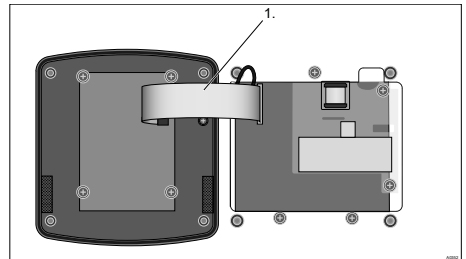

Fig. 58: Pushing and locking the ribbon cable in its base

- 20.** ▶ Push and lock the ribbon cable (1) in its base
- 21.** ▶ Screw the top part of the controller housing onto the lower part of the DULCOMETER® Compact Controller housing
- 22.** ▶ Re-check that the profile seals are fitted properly
- ⇒ IP 54 degree of protection can only be provided if the control panel is mounted correctly

16 Standards complied with and Declaration of Conformity

The Declaration of Conformity for the controller is available to download on our homepage.

EN 61010-1 Safety requirements for electrical equipment for measurement, control and laboratory use – Part 1: General requirements

EN 61326-1 Electrical equipment for measuring, control and laboratory use – EMC requirements (for class A and B devices)

DIN EN 50581 - Technical documentation for the assessment of electrical and electronic products with regard to the restriction of hazardous substances

EN 60529 - Degrees of protection provided by enclosures (IP code)

17 Disposal of used parts

- **User qualification:** instructed user, see [Chapter 3.4 'User qualification'](#) on page 15

! NOTICE!

Regulations governing the disposal of used parts

- Note the national regulations and legal standards that currently apply in your country

The manufacturer will take back decontaminated used devices providing they are covered by adequate postage.

Decontaminate the device before returning it for repair. To do so, remove all traces of hazardous substances. Refer to the Material Safety Data Sheet for your feed chemical.

A current Declaration of Decontamination is available to download on the ProMinent website.

Sign indicating EU collection system

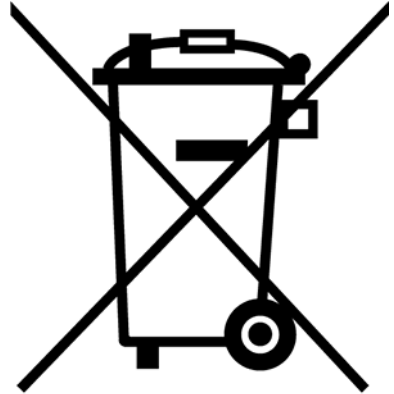

In accordance with the European Directive 2012/19/EU on waste electrical and electronic equipment, this device features the symbol showing a waste bin with a line through it. The device must not be disposed of along with domestic waste. To return the device, use the return and collection systems available and observe the local legal requirements.

18 Index**A**

Accessories	109
Action, step by step	2
Ambient conditions	103
Assembled sensor cables	42

B

Basic functions	17
Bleeding	17
Bottom section of the control housing	25

C

Cable connection set	18
Cable ties	21
Cables prone to faults	30
Check strap	109
Check strap for strain relief	110
Chemical Resistance	104
Configuration	17
Construction of the sensor	43
Contrast setting	52
Control panel cut-out	23, 25

D

Deburring the edges	23
Declaration of Conformity	118
Degree of protection IP 54	25, 39
Degree of protection IP 67	39
Description and function of the terminals	32
Dimensions	103
Drill	23

Drill holes	21
Drilling template	23

E

Error Logger	97
------------------------	----

F

Fine fuse 5x20 T 0.315 A	109
------------------------------------	-----

G

General non-discriminatory approach	2
General water treatment	17

H

Hysteresis	68
----------------------	----

I

Identity code	7
Incorrect metering	45
Intended Use	14

L

Large threaded connection (M 20 x 1.5)	39
Legend for "Wiring" table	32
Links to elements or sections of these instructions or other applicable documents	2

M

Material thickness of control panel	22
Max. switching current:	108
Max. switching voltage:	108
Measuring principle	43

More symbols	2	Question: How is initial commis- sioning done?	45
Mounting (mechanical)	20	Question: How should the controller be mounted in terms of its reading, mounting and operating position?	19
Mounting kit	22	Question: How should the sensor cable be assembled?	31
Mounting materials	20	Question: Is there a legend for the "Wiring" table?	32
Mounting position	19	Question: What applications is the controller intended for?	17
N		Question: What can be calibrated? . . .	56
Noise generation	104	Question: What can the output relays do?	17
Non-discriminatory approach	2	Question: What control direction is available?	17
O		Question: What do I have to consider in terms of recycling?	19
Operating elements	50	Question: What do the LEDs indicate? .	17
Original Prominent cable	32	Question: What happens in the event of incorrect calibration?	57
Overview of equipment	50	Question: What information is made available in the continuous display? . .	53
P		Question: What information is made available in the info display?	54
Pipe bracket	21	Question: What is the load capacity of the hinge?	18
Pipe diameter	21	Question: What needs to be consid- ered in terms of accessibility?	18
plant rooms	104	Question: When are the actuators reset to factory settings?	45
Preparing the control panel	23	Question: Where can I find the Decla- ration of Conformity?	118
Profile seal	25	Question: Which cable is connected to which threaded connector?	32
Punch out threaded holes	39	Question: Which measured variables can be processed?	17
Q			
Question: Does the control have to be adjusted during commissioning?	45		
Question: Does the system have tem- perature compensation?	92		
Question: How are the unit and sensor calibrated?	56		
Question: How do I calibrate the sen- sor's zero point?	64		
Question: How do I vent the pump, for example?	90		

Index

Question: Which sensors can I connect to the controller? 42

Question: Which standards are complied with? 118

R

Reducing inserts 39

Replacing spare part units 110

Replacing the lower part of the housing (control panel installation) . . 115

Replacing the lower part of the housing (wall/tube retaining bracket) 112

Replacing the top part of the housing 110

S

Selection of the connected sensor . . . 42

Sensor connector 42

Small threaded connection (M 16 x 1.5) 39

Snap-hooks 21

Sound Pressure Level 104

Spare parts 109

Standard scope of delivery 18

Standards complied with 118

Strain relief 25, 39

T

Terminal diagram 38

Top section of the control housing . . . 25

U

User qualification 15

V

Venting 90

W

Wall/pipe bracket 21

Warning information 11

Washer 20

Weights 103

Wiring 32

Z

ZERO 64

Zero point 64



ProMinent GmbH
Im Schuhmachergewann 5 - 11
69123 Heidelberg
Telephone: +49 6221 842-0
Fax: +49 6221 842-419
Email: info@prominent.com
Internet: www.prominent.com

984705, 3, en_GB