

Pneumados

Pneumatically-driven diaphragm metering pump

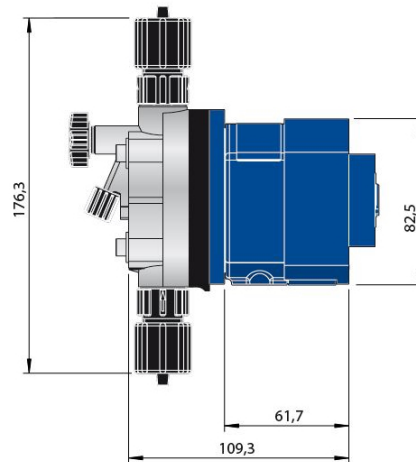

The standard solution for simple metering tasks wherever no electrical power is available.

Capacity range

- 0.76 – 16.7 l/h, 16 – 2 bar
- Continuous stroke length adjustment
- Material versions PVT and stainless steel
- Stroke rate of up to 180 strokes/min

Typical applications

- Car-washing systems
- Animal feed treatment
- Bottle disinfection in bottling plants

Pump type	Pump capacity at max. back pressure			Stroke rate	Suction lift	Connector size
	bar	l/h	ml/stroke	Strokes/min	mWs	a Ø x i Ø mm
PNDb 1000	10	0.76	0.07	180	6.0	6 x 4
PNDb 1601	16	1.00	0.09	180	6.0	6 x 4
PNDb 1602	16	1.70	0.16	180	6.0	6 x 4
PNDb 1005	10	3.80	0.35	180	5.0	8 x 5 ¹⁾
PNDb 0708	7	6.30	0.58	180	4.0	8 x 5
PNDb 0413	4	10.50	0.97	180	3.0	8 x 5
PNDb 0220	2	16.70	1.55	180	2.0	12 x 9

1) With stainless steel design 6 x 4 mm

Wetted materials

Design	Dosing head	Suction/pressure connector	Seals	Valve balls
PVT	PVDF	PVDF	PTFE	Ceramic
SST	Stainless steel material no. 1.4404	Stainless steel material no. 1.4404	PTFE	Ceramic

SYDNEY OFFICE
 Unit 4, 4 Narabang Way,
 BELROSE NSW 2085
 P 02 9450 0995
 sales@prominentfluid.com.au

QUEENSLAND OFFICE
 Unit 1, 68 Murdoch Circuit,
 ACACIA RIDGE QLD 4110
 P 07 3213 1900
 pfcqld@prominentfluid.com.au

VICTORIA OFFICE
 27 Sierra Circuit
 PAKENHAM VIC 3810
 P 03 8795 7430
 pfcvic@prominentfluid.com.au

WESTERN AUSTRALIA OFFICE
 2/158 Francisco Street
 BELMONT WA 6104
 pfcwa@prominentfluid.com.au