



**SDMA Pump Series -
Submersible
Slurry Pump**



Aquaplus SDMA Series - High effective motor competent to pump highly laden mud water. The impeller and agitator made of high chrome alloy ensure great durability. Semi Vortex impeller design reduces the clogging situation by sand.



Main Advantages

- Built for slurry: engineered for mud water and high-solids fluids
- Wear-resistant: high chrome alloy impeller and agitator resist abrasive solids
- Clog-resistant: semi vortex impeller keeps solids moving through
- Fully submersible: IP68 rated to 10m depth
- Flexible power: single phase, three phase, or custom voltage

Application

- Civil Engineering, building sites, basement or other utility pits, rainwater, mudwater, and high viscosity fluids.

Specification

- Water temperature: up to 40°C
- Head: up to 57 meters
- Power: 1.5kW (2HP) to 15 kW (20HP)
- Power supply:
 - single phase 220V \pm 10%, 50Hz, 60Hz
 - three phase 380V \pm 10%, 50Hz, 60Hz
- Insulation class: F
- Protection class: IP68
- Cable length: 8m
- Max. water depth: 10m

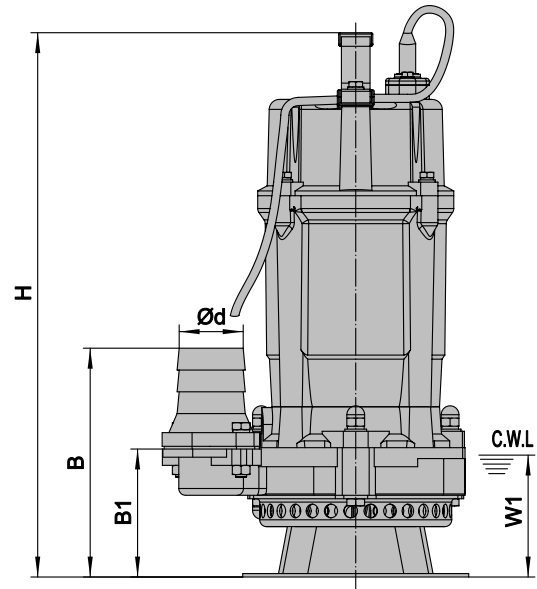
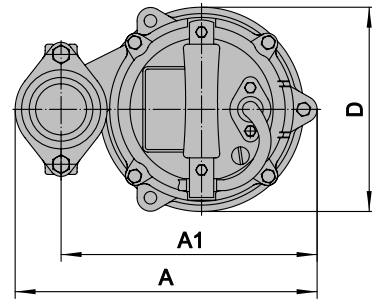
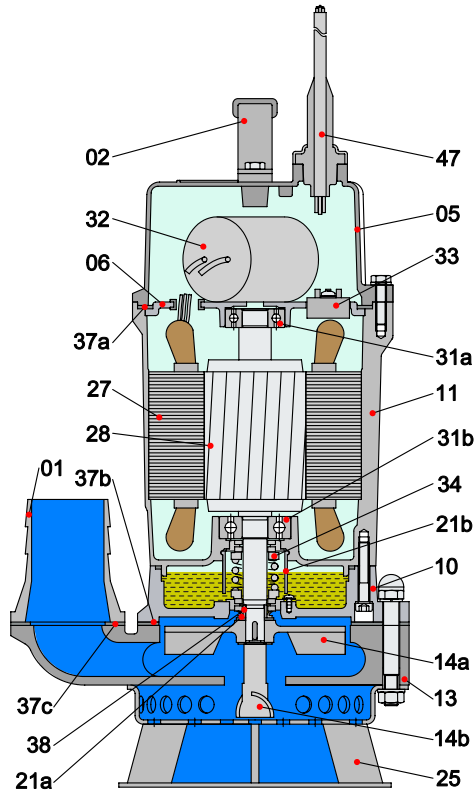

C.W.L.:Continuous running water level

Material of construction

Item No.	Part Name	Material
01	Hose coupling	Cast Iron
02	Handle	Rubber & Steel
05	Upper cover	Aluminum die casting
06	Up-Bearing house	Cast Iron
10	Seal house	Cast Iron
11	Motor body	Aluminum die casting
13	Pump body	Cast Iron
14a	Impeller	High chrome alloy
14b	Agitator	High chrome alloy
21a	Oil riser	NBR
21b	Sand guard	LDPE
25	Strainer	Steel

Item No.	Part Name	Material
27	Stator	
28	Rotor	Shaft: AISI420SS
31a	Bearing	Ball bearing
31b	Bearing	Ball bearing
32	Capacitor	
33	Motor Protector	
34	Mechanical Seal	Ceramic-Sic/Carbon-Ceramic
37a	Gasket	NBR
37b	Gasket	NBR
37c	Gasket	NBR
38	Shaft Sleeve	AISI420SS
47	Cable	H07RN-F

Dimensions & weights

Model (50/60Hz)	d	A	A1	B	B1	D	H	W1	N.W	G.W	Packing Dimension mm
	mm	mm	mm	mm	mm	mm	mm	mm	Kg	Kg	
SDMA-50-52-.55S2	50	237	201	168	95	160	405	95	15.5	17	455x255x230
SDMA-50-52-.55M2	50	237	201	168	95	160	405	95	14	15.5	455x255x230

All content is subject to change without notice.

Performance curves

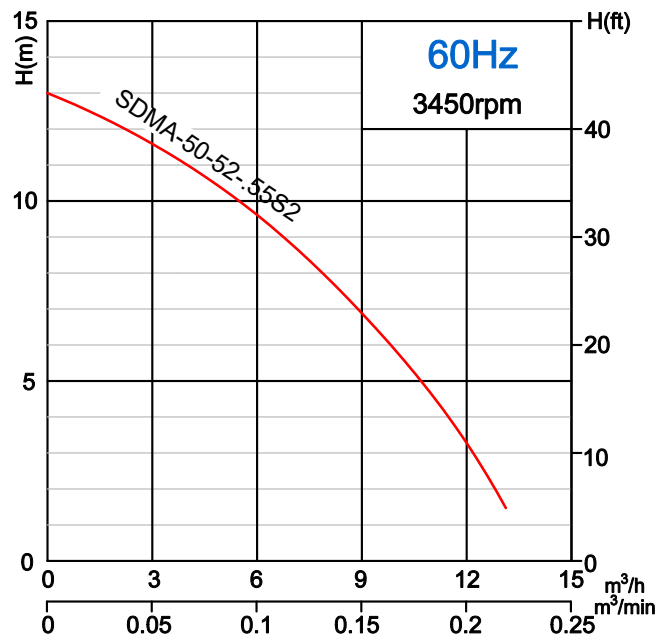
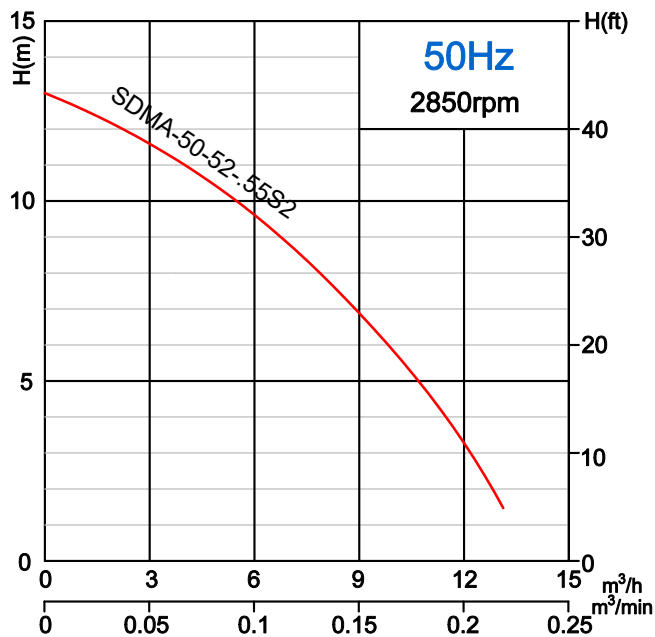

Performance table

Model (50Hz)	Outlet	Motor Power		Rated Current (A)		Rated Capacity		Rated Head	Max Capacity		Max Head	Impeller Passage
	mm	kW	HP	1~	3~	m³/h	m³/min	m	m³/h	m³/min	m	mm
FD(M)2.55(F)	50	0.55	0.75	4.0	1.7	8	0.13	8	13.2	0.22	13	9

The logo for Aquaplus, featuring the word "Aquaplus" in a blue, italicized sans-serif font. A blue swoosh underline is positioned beneath the letters "a" and "q".

EXCLUSIVELY DISTRIBUTED BY

The logo for Malcolm Thompson Pumps, consisting of a blue swoosh underline above the text "MALCOLM THOMPSON" in a blue sans-serif font, with the word "PUMPS" in a larger, bold, blue sans-serif font below it.

1800 733 687

www.mtp.com.au | mtp@mtp.com.au

For information on these products or for any specialised requirements
please contact your local Aquaplus distributor or visit our
website at www.aquapluspumps.com.au